

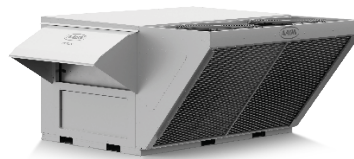

RN SERIES

(6-30 tons)

Packaged Rooftop Units, Heat Pumps,
& Outdoor Air Handling Units



Installation, Operation, & Maintenance



! WARNING

FIRE OR EXPLOSION HAZARD

Failure to follow safety warnings exactly could result in serious injury, death or property damage.

Be sure to read and understand the installation, operation, and service instructions in this manual.

Improper installation, adjustment, alteration, service, or maintenance can cause serious injury, death, or property damage.

A copy of this IOM must be kept with the unit.

! WARNING

- Do not store gasoline or other flammable vapors and liquids in the vicinity of this or any other appliance
- **WHAT TO DO IF YOU SMELL GAS**
 - Do not try to light any appliance.
 - Do not touch any electrical switch; do not use any phone in your building.
 - Leave the building immediately.
 - Immediately call your gas supplier from a phone remote from the building. Follow the gas supplier's instructions.
 - If you cannot reach your gas supplier, call the fire department.
- Startup and service must be performed by a Factory Trained Service Technician.

Table of Contents

| | |
|--|----|
| AAON® RN Series Features and Options Introduction | 6 |
| Safety | 6 |
| RN Series Feature String Nomenclature..... | 9 |
| General Information..... | 28 |
| Codes and Ordinances | 28 |
| Receiving Unit | 29 |
| Storage | 29 |
| Wiring Diagrams | 30 |
| Installation | 30 |
| Locating Units | 30 |
| Setting the Curb | 32 |
| Forklifting the Unit (6-25 and 30 ton) | 37 |
| Lifting the Unit | 37 |
| Duct Connection | 39 |
| Seismic Curb Installation..... | 40 |
| Outside Air Rain Hood | 42 |
| End Flashing Installation | 43 |
| Metal Mesh Filters (6-25 and 30 ton Units) | 43 |
| Electrical | 44 |
| Variable Speed Compressors | 47 |
| Thermostat Control Wiring..... | 47 |
| Condensate Drain Piping | 48 |
| Draw-Through Coils | 49 |
| Startup..... | 50 |
| Filters | 50 |
| Supply Fans | 50 |
| Power Return Axial Flow Fans (16-25 and 30 tons) | 52 |
| Power Return and Exhaust Axial Flow Fans (26 and 31-140 tons)..... | 54 |
| Adjusting Refrigerant Charge..... | 55 |
| Checking Liquid Sub-Cooling..... | 55 |
| Checking Evaporator Superheat | 56 |
| Adjusting Sub-cooling and Superheat Temperatures | 58 |
| Freeze Stat Startup | 58 |
| Condenser Fan Electronically Commutated Motor (ECM) Startup | 61 |
| VFD Controlled Condenser Fan Startup..... | 61 |
| Adjustable Fan Cycling Switch Procedure | 62 |
| Operation | 64 |
| Thermostat Operation | 64 |
| Packaged DX Cooling Operation and Control | 64 |
| Gas Heater Operation..... | 64 |
| Electric Heating Operation | 65 |
| Steam or Hot Water Preheating and Heating Operation..... | 65 |
| Modulating Electric Preheat | 65 |
| Chilled Water or Non-Compressorized DX Cooling Operation..... | 65 |

| | |
|--|-----|
| Maintenance..... | 65 |
| Supply Fans | 65 |
| Power Exhaust Motor and Belt Removal | 66 |
| DX Cooling..... | 67 |
| Condensate Drain Pans | 67 |
| Brazed Plate Heat Exchanger Cleaning..... | 67 |
| E-Coated Coil Cleaning..... | 68 |
| Microchannel Coil Cleaning..... | 69 |
| Options..... | 71 |
| Heating Coils | 71 |
| Chilled Water Coil..... | 72 |
| Packaged Direct Expansion (DX) Units | 73 |
| Variable Capacity Compressor Controller..... | 74 |
| Evaporator Coil (6-25 and 30 ton)..... | 76 |
| Condenser Fans (6-25 and 30 ton)..... | 76 |
| Suction Filter (55, 65 and 75-140 ton)..... | 77 |
| Suction Filter Removal Instructions | 78 |
| Refrigerant-to-Water Heat Exchanger..... | 78 |
| Water-Source Heat Pump Applications..... | 78 |
| Open Loop Applications..... | 78 |
| Freezing Water in the Heat Exchanger | 79 |
| Water Piping | 80 |
| Energy Recovery Units..... | 82 |
| Aluminum Energy Recovery Wheel..... | 83 |
| Polymer Energy Recovery Wheel | 85 |
| Energy Recovery Wheel General Cleaning..... | 92 |
| Energy Recovery Wheel Defrost Timer Setting..... | 94 |
| Gas or Electric Heating..... | 95 |
| Electric Preheat..... | 97 |
| Status Display Screens..... | 97 |
| System Setting Screens..... | 98 |
| LED Flash Alarm Codes..... | 99 |
| Operation | 100 |
| Gas Heating | 100 |
| Piping Sizing Examples..... | 102 |
| Inlet and Manifold Pressures | 102 |
| Gas Pressure Regulator & Overpressure Protection Device..... | 103 |
| Piping Supports..... | 103 |
| Additional Gas Piping Considerations..... | 103 |
| Leak Testing | 106 |
| Gas Heater Operating Instructions..... | 107 |
| Gas Heating Maintenance..... | 108 |
| Gas Heat Exchanger Removal | 109 |
| Phase and Brownout Protection Module | 110 |
| Filter Replacement..... | 112 |

| | |
|--|-----|
| Replacement Parts..... | 118 |
| Appendix A - Heat Exchanger Corrosion Resistance..... | 121 |
| Appendix B - Thermistor Temperature vs. Resistance Values..... | 123 |
| RN Series Startup Form..... | 124 |
| Maintenance Log..... | 128 |
| Maintenance Log (E-Coated Coil)..... | 129 |
| Literature Change History..... | 130 |

Index of Tables and Figures

Tables

| | |
|--|-----|
| Table 1- A Cabinet Unit Clearances..... | 30 |
| Table 2 - B Cabinet Unit Clearances..... | 31 |
| Table 3- C Cabinet Unit Clearances..... | 31 |
| Table 4 - Nameplate Voltage Markings & Tolerances..... | 43 |
| Table 5 – 35 KAIC Fuse Sizing..... | 45 |
| Table 6 – 65 KAIC Fuse Sizing..... | 45 |
| Table 7 - RN-A through C Cabinet Variable Speed Compressor Turndown Ratio..... | 46 |
| Table 8 - Control Wiring..... | 46 |
| Table 9 - Draw-Through Drain Trap Dimensions (Metric)..... | 48 |
| Table 10 - Draw-Through Drain Trap Dimensions (Imperial)..... | 48 |
| Table 11 - Plenum Fan Set Screw Specifications..... | 51 |
| Table 12 - Pin Location..... | 52 |
| Table 13 - Pin Groove Location..... | 52 |
| Table 14 - Acceptable Fin & Tube Air- Cooled Condenser Coil Refrigeration Circuit Values (Metric)..... | 55 |
| Table 15 -Acceptable Fin & Tube Air- Cooled Condenser Coil Refrigeration Circuit Values (Imperial)..... | 55 |
| Table 16 - Acceptable Water-Cooled Refrigeration Circuit Values (Metric)..... | 55 |
| Table 17 - Acceptable Water-Cooled Refrigeration Circuit Values (Imperial)..... | 55 |
| Table 18 - Acceptable Microchannel Air-Cooled Condenser Coil Liquid Sub-Cooling Values (Metric)..... | 56 |
| Table 19 - Acceptable Microchannel Air-Cooled Condenser Coil Liquid Sub-Cooling Values (Imperial)..... | 56 |
| Table 20 - R-410A Refrigerant Temperature-Pressure Chart (Metric)..... | 58 |
| Table 21 - R-410A Refrigerant Temperature-Pressure Chart (Imperial)..... | 59 |
| Table 22 - ECM Condenser Fan Cycling Options..... | 60 |
| Table 23 - Steam Coil Connection Sizes..... | 71 |
| Table 24 - Hot Water Coil Connection Sizes..... | 71 |
| Table 25 - Chilled Water Coil Connection Sizes..... | 71 |
| Table 26 - Min and Max Water Pressures and Temps..... | 72 |
| Table 27 - Demand Signal vs. Compressor Capacity Modulation..... | 74 |
| Table 28 - Glycol Freezing Points..... | 79 |
| Table 29 - Standard Brazed Plate Heat Exchanger Water Connections..... | 79 |
| Table 30 - Energy Recovery Wheel Cleaning Frequency..... | 92 |
| Table 31 - Electric and Gas Heating Capacities..... | 95 |
| Table 32 - Stages of Electric Preheat..... | 97 |
| Table 33: 6 – 30 ton Gas Connections..... | 100 |
| Table 34 - Natural Gas (m ³ /hr [ft ³ /hr]) Maximum Piping Capacities Specific Gravity = 0.6, Supply Pressure ≤ 3.5 kpa (0.5 psi), Pressure Drop = .93 mmHg (0.5” w.c.)..... | 101 |
| Table 35 - Propane (kW [kBtu/hr]) Maximum Piping Capacities Specific Gravity = 1.52, Supply Pressure = 20.6 mmHg (11” w.c.), Pressure Drop, .93 mmHg (0.5” w.c.)..... | 101 |
| Table 36 - Gas Piping Supports (Metric)..... | 102 |
| Table 37 – Gas Piping Supports (Imperial)..... | 102 |

| | |
|--|-----|
| (RAB = Return Air Bypass, PE = Power Exhaust and PR = Power Return) Table 38- 6-8 and 10 ton Pre Filters | 111 |
| Table 39 - 9 and 11-15 ton Pre Filters | 111 |
| Table 40 - 14, 16-25 and 30 ton Pre Filters..... | 111 |
| Table 41 - 6-8 and 10 ton Unit Filters..... | 112 |
| Table 42 - 9 and 11 ton Unit Filters | 113 |
| Table 43 - 13 and 15 ton Unit Filters | 113 |
| Table 44 - 14, 16-25 and 30 ton Unit Filters..... | 113 |
| Table 45 - 6-8 and 10 ton Energy Recovery Wheel Filters..... | 114 |
| Table 46 - 9 and 11-15 ton Energy Recovery Wheel Filters..... | 115 |
| Table 47 - 14, 16-25 and 30 ton Energy Recovery Wheel Filters..... | 115 |

Figures

| | |
|---|----|
| Figure 1 – Lockable Handle..... | 29 |
| Figure 2- RN Series A, B and C Cabinet, 6-25 and 30 tons..... | 31 |
| Figure 3- RN Series 6-8 and 10 ton Unit Isolator Locations | 32 |
| Figure 4- RN Series 9 and 11-15 ton Unit Isolator Locations | 33 |
| Figure 5- RN Series 16-25 and 30 ton Unit Isolator Locations | 34 |
| Figure 6 - Steel Mounting | 35 |
| Figure 7 - Forklifting an RN Series A, B and C Cabinet, 6-25 and 30 tons | 36 |
| Figure 8 - Lifting Details of a 6-25 and 30 ton Standard or Power Exhaust Unit..... | 37 |
| Figure 9 - Lifting Details of a 6-25 and 30 ton Energy Recovery Wheel or Power Return Unit..... | 37 |
| Figure 10 - Duct Connection..... | 38 |
| Figure 11 - Solid Bottom Seismic Curb with Filters..... | 39 |
| Figure 12 - Seismic Solid Bottom Curb without Filters Cross Section | 40 |
| Figure 13 - 6-25 and 30 ton Closed Rain Hood | 41 |
| Figure 14 - Rain Hood with Metal Mesh Filter Rack Installation | 42 |
| Figure 15 - Unit Utility Entry | 44 |
| Figure 16 - Back View of Power Switch from Compressor and Control Compartment (6-30 Units)..... | 44 |
| Figure 17 - Draw-Through Drain Trap | 48 |
| Figure 18 - Supply Fan Banding | 50 |
| Figure 19 - Plenum Fan Gap Tolerances | 51 |
| Figure 20 - Fan with the HUB on the Top and RET on the Bottom | 51 |
| Figure 21 - Bushing Mount Location..... | 52 |
| Figure 22 - RET with Pin in Groove 4..... | 52 |
| Figure 23 - Fan HUB and RET Castings | 52 |
| Figure 24- Assembled Fan | 53 |
| Figure 25 - Back of the Fan | 53 |
| Figure 26 - Pin Groove Location | 53 |
| Figure 27 - Pitch Pin Location | 53 |
| Figure 28 - Example Pitch Pin | 54 |
| Figure 29 - 9-25 and 30 ton Supply Fan | 65 |
| Figure 30 – Bolts which connect motor mount to fan..... | 65 |
| Figure 31 - Variable Capacity Compressor Controller | 73 |
| Figure 32 - Compressor Controller Flash Code Details..... | 74 |
| Figure 33 - Evaporator Coil Access..... | 75 |
| Figure 34 - Removal of a Condenser Fan Assembly | 76 |
| Figure 35 - RPE-48-BD filter element..... | 76 |
| Figure 36 - Aluminum Energy Recovery Wheel | 82 |
| Figure 37 - Aluminum ERW Purge Sector Location..... | 82 |
| Figure 38 - Polymer Energy Recovery Wheel | 84 |
| Figure 39 - Wheel Segment Removal Pattern..... | 89 |
| Figure 40 - Defrost Timer | 94 |
| Figure 41 - Temperature Dial..... | 94 |

Figure 42 - Preheat Controller 96
Figure 43- RN Series Gas Heat Exchanger..... 100
Figure 44 - Example 6-30 ton External Gas Piping 104
Figure 45 – RN Gas Heat Exchanger..... 108
Figure 46 - RN Series 6-30 ton Standard Filter Layouts 116

AAON® RN Series Features and Options Introduction

Energy Efficiency

- Direct Drive Backward Curved Plenum Supply Fans
- Two-Step, Variable Capacity and Variable Speed Scroll Compressors
- Airside Economizers
- Factory Installed AAONAIRES® Energy Recovery Wheels
- Double Wall Rigid Polyurethane Foam Panel Construction, R-13 Insulation
- Modulating Natural Gas Heaters
- Modulating/SCR Electric Heaters
- Premium Efficiency Motors
- Variable Speed Supply/Return/Exhaust Fans
- Water-Cooled Condensers
- Air-Source, Water-Source and Geothermal Heat Pumps

Indoor Air Quality

- 100% Outside Air
- Constant Volume Outside Air Control
- Economizer CO₂ Override
- High Efficiency Filtration
- Double Wall Rigid Polyurethane Foam Panel Construction, R-13 Insulation
- Interior Corrosion Protection

Humidity Control

- High Capacity Cooling Coils
- Variable Capacity Compressors
- Factory Installed AAONAIRES Total Energy Recovery Wheels
- Mixed/Return Air Bypass
- Modulating Hot Gas Reheat

Safety

- Burglar Bars
- Freeze Stats
- Hot Water/Steam Preheat Coils
- Electric Preheat
- Phase and Brown Out Protection
- Supply/Return Smoke Detectors

Safety Continued

- Supply/Return Firestats

Installation and Maintenance

- Clogged Filter Switch
- Color Coded Wiring Diagram
- Compressors in Isolated Compartment
- Compressor Isolation Valves
- Convenience Outlet
- Direct Drive Supply Fans
- Hinged Access Doors with Lockable Handles
- Magnehelic Gauge
- Service Lights
- Sight Glass

System Integration

- Chilled Water Cooling Coils
- Controls by Others
- Electric/Natural Gas/LP Heating
- Hot Water/Steam Heating Coil
- Non-Compressorized DX Coils
- Water-Cooled Condensers

Environmentally Friendly

- Zero Degree Cold Climate Air-Source Heat Pump
- Airside Economizers
- Factory Installed AAONAIRES Energy Recovery Wheels
- Mixed/Return Air Bypass
- R-410A Refrigerant

Extended Life

- 5 Year Compressor Warranty
- 15 Year Aluminized Steel Heat Exchanger Warranty
- 25 Year Stainless Steel Heat Exchanger Warranty
- Condenser Coil Guards
- Interior Corrosion Protection
- Coil Polymer E-Coating - 5 Year Coating Warranty
- Stainless Steel Coil Casing
- Stainless Steel Drain Pans

Safety

Attention must be paid to the following statements:

NOTE - Notes are intended to clarify the unit installation, operation, and maintenance.

⚠ CAUTION - Caution statements are given to prevent actions that may result in equipment damage, property damage, or personal injury.

⚠ WARNING - Warning statements are given to prevent actions that could result in equipment damage, property damage, personal injury or death.

⚠ DANGER - Danger statements are given to prevent actions that will result in equipment damage, property damage, severe personal injury or death.

⚠ WARNING

ELECTRIC SHOCK, FIRE OR EXPLOSION HAZARD

Failure to follow safety warnings exactly could result in dangerous operation, serious injury, death or property damage.

Improper servicing could result in dangerous operation, serious injury, death, or property damage.

- Before servicing, disconnect all electrical power to the furnace. More than one disconnect may be provided.
- When servicing controls, label all wires prior to disconnecting. Reconnect wires correctly.
- Verify proper operation after servicing. Secure all doors with key-lock or nut and bolt.

⚠ CAUTION

WHAT TO DO IF YOU SMELL GAS

- Do not try to turn on unit.
- Shut off main gas supply.
- Do not touch any electric switch.
- Do not use any phone in the building.
- Never test for gas leaks with an open flame.
- Use a gas detection soap solution and check all gas connections and shut off valves.

⚠ WARNING

Electric shock hazard. Before servicing, shut off all electrical power to the unit, including remote disconnects, to avoid shock hazard or injury from rotating parts. Follow proper Lockout-Tagout procedures.

! WARNING

FIRE, EXPLOSION OR CARBON MONOXIDE POISONING HAZARD

Failure to replace proper controls could result in fire, explosion, or carbon monoxide poisoning. Failure to follow safety warnings exactly could result in serious injury, death or property damage. Do not store or use gasoline or other flammable vapors and liquids in the vicinity of this appliance.

! WARNING

CARBON MONOXIDE POISONING HAZARD

Failure to follow instructions could result in severe personal injury or death due to carbon-monoxide poisoning, if combustion products infiltrate into the building.

Check that all openings in the outside wall around the vent (and air intake) pipe(s) are sealed to prevent infiltration of combustion products into the building.

Check that furnace vent (and air intake) terminal(s) are not obstructed in any way during all seasons.

! WARNING

During installation, testing, servicing, and troubleshooting of the equipment it may be necessary to work with live electrical components. Only a qualified licensed electrician or individual properly trained in handling live electrical components shall perform these tasks.

Standard NFPA-70E, an OSHA regulation requiring an Arc Flash Boundary to be field established and marked for identification of where appropriate Personal Protective Equipment (PPE) be worn, must be followed.

! CAUTION

Unit power supply wire must be only copper or aluminum.

! WARNING

ROTATING COMPONENTS

Unit contains fans with moving parts that can cause serious injury. Do not open door containing fans until the power to the unit has been disconnected and fan wheel has stopped rotating.

! WARNING

GROUNDING REQUIRED

All field installed wiring must be completed by qualified personnel. Field installed wiring must comply with NEC/CEC, local and state electrical code requirements. Failure to follow code requirements could result in serious injury or death. Provide proper unit ground in accordance with these code requirements.

! WARNING

VARIABLE FREQUENCY DRIVES

Do not leave VFDs unattended in hand mode or manual bypass. Damage to personnel or equipment can occur if left unattended. When in hand mode or manual bypass mode VFDs will not respond to controls or alarms.

! CAUTION

Electric motor over-current protection and overload protection may be a function of the Variable Frequency Drive to which the motors are wired. Never defeat the VFD motor overload feature. The overload ampere setting must not exceed 115% of the electric motor's FLA rating as shown on the motor nameplate.

! WARNING

UNIT HANDLING

To prevent injury or death lifting equipment capacity shall exceed unit weight by an adequate safety factor. Always test-lift unit not more than 24 inches high to verify proper center of gravity lift point to avoid unit damage, injury or death.

! CAUTION

Failure to properly drain and vent coils when not in use during freezing temperature may result in coil and equipment damage.

! CAUTION

Rotation must be checked on all **MOTORS AND COMPRESSORS** of 3 phase units at startup by a qualified service technician. Scroll compressors are directional and can be damaged if rotated in the wrong direction. Compressor rotation must be checked using suction and discharge gauges. Fan motor rotation must be checked for proper operation. Alterations must only be made at the unit power connection

! WARNING

Do not use oxygen, acetylene or air in place of refrigerant and dry nitrogen for leak testing. A violent explosion may result causing injury or death.

! WARNING

WATER PRESSURE

Prior to connection of condensing water supply, verify water pressure is less than maximum pressure shown on unit nameplate. To prevent injury or death due to instantaneous release of high pressure water, relief valves must be field supplied on system water piping.

! WARNING

Always use a pressure regulator, valves and gauges to control incoming pressures when pressure testing a system. Excessive pressure may cause line ruptures, equipment damage or an explosion which may result in injury or death.

! CAUTION

To prevent damage to the unit, do not use acidic chemical coil cleaners. Do not use alkaline chemical coil cleaners with a pH value greater than 8.5, after mixing, without first using an aluminum corrosion inhibitor in the cleaning solution.

! CAUTION

In order to avoid a hazard due to inadvertent resetting of the THERMAL CUT-OUT, this appliance must not be supplied through an external switching device, such as a timer, or connected to a circuit that is regularly switched on and off by the utility.

! WARNING

Some chemical coil cleaning compounds are caustic or toxic. Use these substances only in accordance with the manufacturer's usage instructions. Failure to follow instructions may result in equipment damage, injury or death.

! CAUTION

Do not clean DX refrigerant coils with hot water or steam. The use of hot water or steam on refrigerant coils will cause high pressure inside the coil tubing and damage to the coil.

! CAUTION

Door compartments containing hazardous voltage or rotating parts are equipped with door latches to allow locks. Door latch are shipped with nut and bolts requiring tooled access. If you do not replace the shipping hardware with a pad lock always re-install the nut & bolt after closing the door.

! WARNING

This appliance is not intended for use by persons with reduced physical, sensory or mental capabilities, or lack of experience and knowledge, unless they have been given supervision or instruction concerning use of the appliance by a person responsible for their safety. Children must be supervised around this appliance.

! CAUTION

Cleaning the cooling tower or condenser water loop with harsh chemicals such as hydrochloric acid (muriatic acid), chlorine or other chlorides, can damage the refrigerant-to-water heat exchanger. Care must be taken to avoid allowing chemicals to enter the refrigerant-to-water heat exchanger. See Appendix A - Heat Exchanger Corrosion Resistance for more information.

! WARNING

OPEN LOOP APPLICATIONS

Failure of the condenser as a result of chemical corrosion is excluded from coverage under AAON Inc. warranties and the heat exchanger manufacturer's warranties.

! WARNING

WATER FREEZING

Failure of the condenser due to freezing will allow water to enter the refrigerant circuit and will cause extensive damage to the refrigerant circuit components. Any damage to the equipment as a result of water freezing in the condenser is excluded from coverage under AAON warranties and the heat exchanger manufacturer warranties.

! WARNING

COMPRESSOR CYCLING

3 MINUTE MINIMUM OFF TIME
To prevent motor overheating compressors must cycle off for a minimum of 3 minutes.

5 MINUTE MINIMUM ON TIME
To maintain the proper oil level compressors must cycle on for a minimum of 5 minutes.

The cycle rate must not exceed 7 starts per hour.



! CAUTION

Disconnect power to the unit before servicing UV-C lamps



! CAUTION

Doors and panels with access to UV-C lamps, with possible spectral irradiance exceeding 1.7 $\mu\text{W}/\text{cm}^2$ are provided with an interlock switch. Do not over-ride.



! WARNING

Do not operate UV-C lamps outside of the unit.

 **! WARNING**

Units containing UV-C Germicidal lamps shall not be operated with damage to the cabinet of the unit. UV-C radiation may, even in small doses, cause harm to the eyes and skin.

! WARNING

Units with VFD driven motors/compressors have adjustable overload settings. These are set by the AAON factory for the protection of these motors/compressors and must not be adjusted over this factory setpoint or bypassed.

1. Startup and service must be performed by a Factory Trained Service Technician.
2. Use only with type of the gas approved for the furnace. Refer to the furnace rating plate.
3. The unit is for outdoor use only. See General Information section for more information.
4. Provide adequate combustion ventilation air to the furnace. If a vent duct extension is used, a class III approved vent is required. See the Locating Units and Gas

Heating sections of the Installation section of the manual.

5. Always install and operate furnace within the intended temperature rise range and duct system external static pressure (ESP) as specified on the unit nameplate.
6. The supply and return air ducts must be derived from the same space. It is recommended ducts be provided with access panels to allow inspection for duct tightness. When a down flow duct is used with electric heat, the exhaust duct must be an L shaped duct.
7. Clean furnace, duct and components upon completion of the construction setup. Verify furnace operating conditions including input rate, temperature rise and ESP.
8. Every unit has a unique equipment nameplate with electrical, operational, and unit clearance specifications. Always refer to the unit nameplate for specific ratings unique to the model you have purchased.
9. READ THE ENTIRE INSTALLATION, OPERATION AND MAINTENANCE MANUAL. OTHER IMPORTANT SAFETY PRECAUTIONS ARE PROVIDED THROUGHOUT THIS MANUAL.
10. Keep this manual and all literature safeguarded near or on the unit.

RN Series Feature String Nomenclature

Model Options : Unit Feature Options

| | |
|---|--|
| GEN SIZE VL CONFIG | A1 A2 A3 A4 B1 B2 B3 1A 1B 1C 1D 2 3 4 5A 5B 5C 6A 6B 6C 7 8 9 10 11 12 13 14A 14B 15 16 17 18 19 20 21 22 23 |
|---|--|

RN-025-3-0-BB02-384:A000-D0B-DEH-0BA-0D0000L-00-00B00000B

BASE MODEL

SERIES AND GENERATION

RN

UNIT SIZE

- 006 = 6 ton Capacity
- 007 = 7 ton Capacity
- 008 = 8 ton Capacity
- 009 = 9 ton Capacity
- 010 = 10 ton Capacity
- 011 = 11 ton Capacity
- 013 = 13 ton Capacity
- 014 = 14 ton Capacity
- 015 = 15 ton Capacity
- 016 = 16 ton Capacity
- 018 = 18 ton Capacity
- 020 = 20 ton Capacity
- 025 = 25 ton Capacity
- 026 = 26 ton Capacity
- 030 = 30 ton Capacity

VOLTAGE

- 1 = 230V/1Φ/60Hz
- 2 = 230V/3Φ/60Hz
- 3 = 460V/3Φ/60Hz
- 4 = 575V/3Φ/60Hz
- 6 = 380V/3Φ/50Hz
- 8 = 208V/3Φ/60Hz
- 9 = 208V/1Φ/60Hz

INTERIOR PROTECTION

0 = Standard - Vertical Discharge and Return
 A = Interior Corrosion Protection - Vertical Discharge and Return

Model Option A: COOLING/HEAT PUMP

A1: REFRIGERANT STYLE

- 0 = Air Handling Unit
- B = R-410A - High Efficiency
- C = R-410A - Standard Efficiency
- E = R-410A Variable Capacity Scroll Compressor - High Efficiency
- F = R-410A Variable Capacity Scroll Compressor - Standard Efficiency
- G = R-410A Two-Stage Compressor - High Efficiency
- H = R-410A Variable Capacity Scroll Compressor + Two-Stage Compressor - High Efficiency
- K = R-410A Variable Speed Scroll Compressor - High Efficiency

A2: UNIT CONFIGURATION

- 0 = No Cooling
- A = Air-Cooled Cond. + Std Evap. Coil
- B = Air-Cooled Cond. + 6 Row Evap. Coil
 J = Water-Cooled Cond. + Std Evap. Coil
- K = Water-Cooled Cond. + 6 Row Evap. Coil
- P = Air-Cooled Cond. + 6 Row Evap. Coil + Mixed Air Bypass
- Q = Air-Cooled Cond. + 6 Row Evap. Coil + Return Air Bypass
- R = Water-Cooled Cond. + 6 Row Evap. Coil + Return Air Bypass
- T = Water-Cooled Cond. + 6 Row Evap. Coil + Mixed Air Bypass
- U = Chilled Water Coil - 4 Row
 W = Chilled Water Coil - 6 Row
- 2 = Non-Compressorized + Std Evap. Coil
- 4 = Non-Compressorized + 6 Row Evap. Coil
 6 = Air-Source Heat Pump
- 6 = Zero Degree Cold Climate Air-Source Heat Pump (when A1=K)
- 7 = Water-Source/Geothermal Heat Pump

RN Series Feature String Nomenclature

Model Options : Unit Feature Options

| GEN | SIZE | VLT | CONFIG | A1 | A2 | A3 | A4 | B1 | B2 | B3 | 1A | 1B | 1C | 1D | 2 | 3 | 4 | 5A | 5B | 5C | 6A | 6B | 6C | 7 | 8 | 9 | 10 | 11 | 12 | 13 | 14A | 14B | 15 | 16 | 17 | 18 | 19 | 20 | 21 | 22 | 23 | | | | |
|-----|------|-----|--------|----|----|-----|----|----|----|----|----|----|----|----|---|---|----|----|----|----|-----|----|----|----|---|---|----|----|----|----|-----|-----|----|----|----|----|----|----|----|----|----|---|---|---|---|
| RN | -0 | 2 | 5 | -3 | -0 | -BB | 0 | 2 | -3 | 8 | 4 | : | A | 0 | 0 | 0 | -D | 0 | B | - | DEH | - | 0 | BA | - | 0 | D | 0 | 0 | 0 | 0 | L | - | 0 | 0 | - | 0 | 0 | B | 0 | 0 | 0 | 0 | 0 | B |

Model Option A: COOLING/HEAT PUMP

A3: COIL COATING

- 0 = Standard
- 1 = Polymer E-Coated Evap. and Cond.
- 8 = Polymer E-Coated Cond.
- 9 = Polymer E-Coated Cooling Coil
- A = Stainless Steel Evap. Coil Casing + Polymer E-Coated Cond. Coil
- D = Stainless Steel Cooling Coil Casing
- J = Stainless Steel Evap. Coil Casing + Polymer E-Coated Evap. Coil
- K = Stainless Steel Casing (Evap Only) + Polymer E-Coated Coils (Evap & Cond)

A4: COOLING/HEAT PUMP STAGING

- 0 = No Cooling
- 1 = 1 Stage
- 2 = 2 Stage
- 4 = 4 Stage
- 5 = 5 Stage
- 9 = Modulating - Lead VCC
- A = Modulating - All VCC
- B = 1 Stage Heat Pump + 1 Stage Auxiliary Heat
- C = 2 Stage Heat Pump + 1 Stage Auxiliary Heat
- D = 4 Stage Heat Pump + 1 Stage Auxiliary Heat
- E = Modulating Heat Pump - Lead VCC + 1 Stage Aux. Heat
- F = Modulating Heat Pump - All VCC + 1 Stage Aux. Heat
- H = Single Serpentine 8 fpi
- J = Half Serpentine 8 fpi
- K = Single Serpentine 10 fpi
- L = Half Serpentine 10 fpi
- M = Single Serpentine 12 fpi
- N = Half Serpentine 12 fpi
- P = 1 Stage Heat Pump + 2 Stage Auxiliary Heat
- Q = 2 Stage Heat Pump + 2 Stage Auxiliary Heat
- R = 4 Stage Heat Pump + 2 Stage Auxiliary Heat
- S = Modulating Heat Pump - Lead VCC + 2 Stage Aux. Heat
- T = Modulating Heat Pump - All VCC + 2 Stage Aux. Heat
- U = 1 Stage Heat Pump + 4 Stage Auxiliary Heat

A4: COOLING/HEAT PUMP STAGING – Cont.

- V = 2 Stage Heat Pump + 4 Stage Auxiliary Heat
- W = 4 Stage Heat Pump + 4 Stage Auxiliary Heat
- Y = Modulating Heat Pump - Lead VCC + 4 Stage Aux. Heat
- Z = Modulating Heat Pump - All VCC + 4 Stage Aux. Heat

Model Option B: HEATING

B1: HEATING TYPE

- 0 = No Heating
- 1 = Electric Heat
- 2 = Natural Gas Aluminized
- 3 = Natural Gas Stainless Steel
- 4 = High Altitude Natural Gas Aluminized
- 5 = High Altitude Natural Gas Stainless Steel
- 6 = LP Gas Aluminized
- 7 = LP Gas Stainless Steel
- 8 = High Altitude LP Gas Aluminized
- 9 = High Altitude LP Gas Stainless Steel
- C = Steam Distributing Standard
- D = Steam Distributing Polymer E-Coated
- E = Hot Water Standard
- F = Hot Water Polymer E-Coated

RN Series Feature String Nomenclature

Model Options : Unit Feature Options

| | |
|--|--|
| GEN SIZE VLT CONFIG A1 A2 A3 A4 B1 B2 B3 1A 1B 1C 1D 2 3 4 5A 5B 5C 6A 6B 6C 7 8 9 10 11 12 13 14A 14B 15 16 17 18 19 20 21 22 23 | RN - 0 2 5 - 3 - 0 - BB 0 2 - 3 8 4 : A 0 0 0 - D0 B - DEH - 0 BA - 0 D 0 0 0 0 L - 0 0 - 0 0 B 0 0 0 0 0 B |
|--|--|

Feature 2: OUTSIDE AIR CONTROL

0 = Standard - None
 A = 3 Position Actuator - Sensible Limit
 B = 3 Position Actuator - Enthalpy Limit
 C = Fully Modulating Actuator - Sensible Limit
 D = Fully Modulating Actuator - Enthalpy Limit
 E = DDC Actuator
 F = Constant Volume Outside Air
 G = Options A + F
 H = Options B + F
 J = Options C + F
 K = Options D + F
 L = Options E + F
 M = 3 Pos. Act. - Sensible Limit + CO2 Override
 N = 3 Pos. Act. - Enthalpy Limit + CO2 Override
 P = Fully Mod. Act. - Sensible + CO2 Override
 Q = Fully Mod. Act. - Enthalpy + CO2 Override
 R = DDC Actuator + CO2 Override
 S = Dual Minimum Position Potentiometers + Fully Mod. Act. - Sensible Limit
 T = Dual Minimum Position Potentiometers + Fully Mod. Act. - Enthalpy Limit
 U = 2 Position Actuator
 Y = Fault Detection and Diagnostics Controller (FDD) Sensible Limit
 Z = FDD Enthalpy Limit
 1 = FDD Sensible Limit + CO2 Override
 2 = FDD Enthalpy Limit + CO2 Override

Feature 3: HEAT OPTIONS

0 = Standard - None
 E = Discharge Air Override
 K = Auxiliary Heat K
 L = Auxiliary Heat L
 M = Auxiliary Heat M
 N = Auxiliary Heat N
 P = Auxiliary Heat P
 Q = Auxiliary Heat Q
 R = Auxiliary Heat R
 S = Auxiliary Heat S
 T = Auxiliary Heat T
 U = Auxiliary Heat U
 V = Auxiliary Heat V
 W = Auxiliary Heat W

Feature 4: MAINTENANCE OPTIONS

0 = Standard - None
 A = Field Wired 115V Outlet
 B = Factory Wired 115V Outlet
 C = Blower Aux. Contact
 D = Remote Start/Stop Terminals
 E = Options A + C
 F = Options A + D
 G = Options B + C
 H = Options B + D
 J = Options A + C + D
 K = Options B + C + D
 L = Options C + D

RN Series Feature String Nomenclature

Model Options : Unit Feature Options

| GEN | SIZE | VLT | CONFIG | | | | | | | | | | | | | | | | | | | | | | | | | | | | | |
|-----|------|-----|----------------------|----------------|----------------------|----|---|---|----|-----|----|----|----|----|-----|----|----|----|----|------|----|-----|-----|----|-------|----|----|----|----|----|----|----|
| | | | A1 A2 A3 A4 | B1 B2 B3 | 1A 1B 1C 1D | 2 | 3 | 4 | 5A | 5B | 5C | 6A | 6B | 6C | 7 | 8 | 9 | 10 | 11 | 12 | 13 | 14A | 14B | 15 | 16 | 17 | 18 | 19 | 20 | 21 | 22 | 23 |
| RN | -025 | -3 | -0 | -BB | 02 | -3 | 8 | 4 | :A | 000 | -D | 0 | B | - | DEH | -0 | BA | -0 | D | 0000 | L | -00 | -00 | B | 00000 | 0 | 0 | 0 | 0 | 0 | 0 | B |

Feature 5: SUPPLY AIR OPTIONS

5A: SUPPLY AIR BLOWER CONFIGURATION

- 0 = 1 Blower + Standard Efficiency Motor
- A = 2 Blowers + Standard Efficiency Motor
- B = 1 Blower + Premium Efficiency Motor
- C = 2 Blowers + Premium Efficiency Motor
- D = 1 Blower + Premium Efficiency Motor + 1 VFD
- F = 2 Blowers + Premium Efficiency Motors + 2 Motors on 1 VFD
- G = 2 Blowers + Premium Efficiency Motors + 2 Motors on 2 VFDs
- H = 1 Blower + Premium Efficiency TEFC Motor
- J = 2 Blowers + Premium Efficiency TEFC Motors
- K = 1 Blower + Premium Efficiency TEFC Motor + 1 VFD
- L = 2 Blowers + Premium Efficiency TEFC Motors + 2 Motors on 1 VFD
- M = 2 Blowers + Premium Efficiency TEFC Motors + 2 Motors on 2 VFDs
- N = Option D + Shaft Grounding
- P = Option F + Shaft Grounding
- Q = Option G + Shaft Grounding
- R = Option K + Shaft Grounding
- S = Option L + Shaft Grounding
- T = Option M + Shaft Grounding

5B: SUPPLY AIR BLOWER

- B = 15" Backward Curved Plenum
- C = 18.5" Backward Curved Plenum
- D = 24" Backward Curved Plenum
- E = 27" Backward Curved Plenum
- F = 30" BC Plenum - 90% Width + 1750 rpm Max - Aluminum Wheel
- G = 15" BC Plenum - 70% Width
- H = 18.5" BC Plenum - 70% Width
- J = 18.5" Backward Curved Plenum
- K = 18.5" BC Plenum - 60% Width
- L = 30" BC Plenum - 1600 rpm Max - Aluminum Wheel
- M = 13.5" Backward Curved Plenum
- N = 13.5" BC Plenum - 70% Width
- P = 24" BC Plenum - 60% Width
- Q = 27" BC Plenum - 60% Width
- R = 22" Backward Curved Plenum
- S = 22" BC Plenum - 70% Width
- T = 17" Backward Curved Plenum
- U = 17" BC Plenum - 70% Width
- V = 33" Backward Curved Plenum
- W = 36.5" Backward Curved Plenum
- Y = 42.5" Backward Curved Plenum

RN Series Feature String Nomenclature

| GEN | SIZE | VLT | CONFIG | A1 | A2 | A3 | A4 | B1 | B2 | B3 | : | A | 0 | 0 | 0 | - | D | 0 | B | - | DEH | - | 0 | BA | - | 0 | D | 0 | 0 | 0 | 0 | L | - | 0 | 0 | - | 0 | 0 | B | 0 | 0 | 0 | 0 | 0 | 0 | B | | | | | |
|-----|------|-----|--------|----|----|----|----|----|----|----|---|---|---|---|---|---|---|---|---|---|-----|----|----|----|----|----|-----|---|---|----|----|----|----|-----|-----|----|----|----|----|----|----|----|----|----|---|---|---|---|---|---|---|
| GEN | SIZE | VLT | CONFIG | A1 | A2 | A3 | A4 | B1 | B2 | B3 | : | A | 0 | 0 | 0 | - | 2 | 3 | 4 | - | 5A | 5B | 5C | 6A | 6B | 6C | 7 | 8 | 9 | 10 | 11 | 12 | 13 | 14A | 14B | 15 | 16 | 17 | 18 | 19 | 20 | 21 | 22 | 23 | | | | | | | |
| | RN | 0 | 2 | 5 | - | 3 | - | 0 | - | BB | 0 | 2 | - | 3 | 8 | 4 | : | A | 0 | 0 | 0 | - | D | 0 | B | - | DEH | - | 0 | BA | - | 0 | D | 0 | 0 | 0 | 0 | L | - | 0 | 0 | - | 0 | 0 | B | 0 | 0 | 0 | 0 | 0 | B |

5C: SUPPLY AIR BLOWER MOTOR

C = 1 hp - 1760 rpm
 D = 2 hp - 1760 rpm
 E = 3 hp - 1760 rpm
 F = 5 hp - 1760 rpm
 G = 7.5 hp - 1760 rpm
 H = 10 hp - 1760 rpm
 L = 15 hp - 1760 rpm
 M = 20 hp - 1760 rpm
 N = 1 hp - 1170 rpm
 P = 2 hp - 1170 rpm
 Q = 3 hp - 1170 rpm
 R = 5 hp - 1170 rpm
 S = 7.5 hp - 1170 rpm
 T = 10 hp - 1170 rpm
 U = 15 hp - 1170 rpm
 V = 20 hp - 1170 rpm
 W = 25 hp - 1170 rpm
 Y = 30 hp - 1170 rpm
 3 = 25 hp - 1760 rpm
 4 = 30 hp - 1760 rpm
 5 = 40 hp - 1760 rpm
 6 = 50 hp - 1760 rpm

Feature 6: FILTERS

6A: PRE FILTER

0 = Standard - None
 A = 2" Pleated - MERV 8
 B = Metal Mesh Outside Air Filter
 C = Lint Screen Filter
 D = Exhaust Air ERW Filter
 E = Options A + B
 F = Options A + D
 G = Options B + D
 H = Options A + B + D

6B: UNIT FILTER

0 = 2" Pleated - MERV 8
 B = 4" Pleated - MERV 8
 C = 2" Permanent Filter + Replaceable Media
 F = 4" Pleated - MERV 11
 G = 4" Pleated - MERV 13
 H = 4" Pleated - MERV 14

6C: FILTER OPTIONS

0 = Standard
 A = Clogged Filter Switch
 B = Magnehelic Gauge
 C = Options A + B

Feature 7: REFRIGERATION CONTROL

0 = Standard
 A = 5 Min. Time Delay Relay - Comp. Off
 B = 20 Sec. Time Delay Relay - Comp. Staging
 C = Adjustable Fan Cycling
 D = Adjustable Lockout
 E = Freeze Stats - Each Circuit
 F = Options A + B
 G = Options A + C
 H = Options A + D
 J = Options A + E
 K = Options B + C
 L = Options B + D
 M = Options B + E
 N = Adjustable Fan Cycling with Adjustable Compressor Lockout
 P = Options C + E
 Q = Options D + E
 R = Options A + B + C
 S = Options A + B + D
 T = Options A + B + E
 U = Options A + N
 V = Options A + C + E
 W = Options A + D + E
 Y = Options B + N
 Z = Options B + C + E
 1 = Options B + D + E
 2 = Options N + E
 3 = Options A + B + N
 4 = Options A + B + C + E
 5 = Options A + B + D + E
 6 = Options A + N + E
 7 = Options B + N + E
 8 = Options A + B + N + E

RN Series Feature String Nomenclature

Model Options : Unit Feature Options

| GEN | SIZE | VLT | CONFIG | | | | | | | | | | | | | | | | | | | | | | | | | | | | | |
|-----|------|-----|---|-----------|---|---|---|---|---|----|---|---|------|----|----|----|----|---|---|---|---|----|---|----|---|---|---|---|---|---|---|---|
| | | | A1 A2 A3 A4 B1 B2 B3 1A 1B 1C 1D 2 3 4 5A 5B 5C 6A 6B 6C 7 8 9 10 11 12 13 14A 14B 15 16 17 18 19 20 21 22 23 | | | | | | | | | | | | | | | | | | | | | | | | | | | | | |
| RN | -025 | -3 | -0 | -BB02-384 | : | A | 0 | 0 | 0 | -D | 0 | B | -DEH | -0 | BA | -0 | D0 | 0 | 0 | 0 | L | -0 | 0 | -0 | 0 | B | 0 | 0 | 0 | 0 | 0 | B |

Feature 8: REFRIGERATION OPTIONS

- 0 = Standard
- A = Hot Gas Bypass Lead Stage or Hot Gas Bypass Lag Stage with Lead Variable Capacity Compressor
- B = Hot Gas Bypass Lead and Lag Stages
- D = Modulating Hot Gas Reheat
- E = 0°F Low Ambient Lead Stage
- H = Options A + D
- J = Options B + D
- K = Options A + E
- L = Options B + E
- N = Polymer E-Coated Modulating Hot Gas Reheat
- R = Options A + N
- S = Options B + N
- T = Parallel Modulating Hot Gas Reheat Microchannel Coil - Lag Circuit
- U = Options A + T
- V = Options B + T
- W = Polymer E-Coated Parallel Modulating Hot Gas Reheat Microchannel Coil - Lag Circuit
- Y = Options A + W
- Z = Options B + W
- 1 = All Circuit Parallel Modulating Hot Gas Reheat Microchannel Coil
- 2 = Options A + 1
- 3 = Options B + 1
- 4 = Polymer E-Coated All Circuit Parallel Modulating Hot Gas Reheat Microchannel Coil
- 5 = Options A + 4
- 6 = Options B + 4

Feature 9: REFRIGERATION ACCESSORIES

- 0 = Standard
- A = Sight Glass
- B = Compressor Isolation Valves
- C = Options A + B
- D = ECM Condenser Fan - Multiple Speed
- E = ECM Condenser Fan - Head Pressure Control
- F = VFD Controlled Condenser Fans - Variable Speed
- G = Options A + D
- H = Options B + D
- J = Options A + B + D
- K = Options A + E
- L = Options B + E
- M = Options A + B + E
- N = Options A + F
- P = Options B + F
- Q = Options C + F
- R = Low Sound Condenser Fan - Head Pressure Control
- S = Options R + A
- T = Options R + B
- U = Options R + A + B

RN Series Feature String Nomenclature

Model Options : Unit Feature Options

| GEN | SIZE | VLT | CONFIG | | | | | | | | | | | | | | | | | | | | | | | | | | | | | | | | | | |
|-----|------|-----|---|-----|---|-----|---|---|---|---|---|---|---|----|---|---|------|----|----|----|---|---|---|---|---|---|----|---|----|---|---|---|---|---|---|---|---|
| | | | A1 A2 A3 A4 B1 B2 B3 1A 1B 1C 1D 2 3 4 5A 5B 5C 6A 6B 6C 7 8 9 10 11 12 13 14A 14B 15 16 17 18 19 20 21 22 23 | | | | | | | | | | | | | | | | | | | | | | | | | | | | | | | | | | |
| RN | -0 | 2 | 5-3-0 | -BB | 0 | 2-3 | 8 | 4 | : | A | 0 | 0 | 0 | -D | 0 | B | -DEH | -0 | BA | -0 | D | 0 | 0 | 0 | 0 | L | -0 | 0 | -0 | 0 | B | 0 | 0 | 0 | 0 | 0 | B |

Feature 10: POWER OPTIONS

- 0 = Standard Power Block
- A = 100 Amp Power Switch
- B = 150 Amp Power Switch
- C = 225 Amp Power Switch
- D = 400 Amp Power Switch
- E = 600 Amp Power Switch
- F = 500 Amp Circuit Breaker
- 5 = 800 Amp Power Switch
- 6 = 1200 Amp Power Switch
- G = 15 Amp Circuit Breaker
- H = 20 Amp Circuit Breaker
- J = 25 Amp Circuit Breaker
- K = 30 Amp Circuit Breaker
- L = 35 Amp Circuit Breaker
- M = 40 Amp Circuit Breaker
- N = 45 Amp Circuit Breaker
- P = 50 Amp Circuit Breaker
- Q = 60 Amp Circuit Breaker
- R = 70 Amp Circuit Breaker
- S = 80 Amp Circuit Breaker
- T = 90 Amp Circuit Breaker
- U = 100 Amp Circuit Breaker
- V = 110 Amp Circuit Breaker
- W = 125 Amp Circuit Breaker
- Y = 150 Amp Circuit Breaker
- Z = 175 Amp Circuit Breaker
- 1 = 200 Amp Circuit Breaker
- 2 = 225 Amp Circuit Breaker
- 3 = 250 Amp Circuit Breaker
- 4 = 300 Amp Circuit Breaker
- 7 = 350 Amp Circuit Breaker
- 8 = 400 Amp Circuit Breaker
- 9 = 450 Amp Circuit Breaker

Feature 11: SAFETY OPTIONS

- 0 = Standard
- A = Return and Supply Air Firestat
- B = Return Air Smoke Detector
- C = Supply Air Smoke Detector
- D = Options B + C
- E = Options A + B
- F = Options A + C
- G = Options A + B + C
- H = Remote Smoke Detector Terminals
- J = Options A + H
- K = Options B + H
- L = Options C + H
- M = Options D + H
- N = Options A + B + H
- P = Options A + C + H
- Q = Options A + B + C + H
- R = High Condensate Level Switch
- S = Options A + R
- T = Options B + R
- U = Options C + R
- V = Options D + R
- W = Options H + R
- Y = Options E + R
- Z = Options F + R
- 1 = Options G + R
- 2 = Options J + R
- 3 = Options K + R
- 4 = Options L + R
- 5 = Options M + R
- 6 = Options N + R
- 7 = Options P + R
- 8 = Options Q + R

RN Series Feature String Nomenclature

| Model Options | | | | | | | | | | : | Unit Feature Options | | | | | | | | | | | | | | | | | | | | | | | | | | | | | | | |
|---------------|------|-----|--------|----|----|-----|----|----|----|----|----------------------|----|----|----|---|---|----|----|----|------|----|----|----|---|---|---|----|----|----------|----------|-----|-----|----|----|----|----|----|----|----|----|----|---|
| GEN | SIZE | VLT | CONFIG | A1 | A2 | A3 | A4 | B1 | B2 | B3 | 1A | 1B | 1C | 1D | 2 | 3 | 4 | 5A | 5B | 5C | 6A | 6B | 6C | 7 | 8 | 9 | 10 | 11 | 12 | 13 | 14A | 14B | 15 | 16 | 17 | 18 | 19 | 20 | 21 | 22 | 23 | |
| RN | -0 | 2 | 5 | -3 | -0 | -BB | 0 | 2 | -3 | 8 | 4 | : | A | 0 | 0 | 0 | -D | 0 | B | -DEH | -0 | BA | -0 | D | 0 | 0 | 0 | 0 | 0 | L | -0 | 0 | -0 | 0 | B | 0 | 0 | 0 | 0 | 0 | 0 | B |

Feature 12: CONTROLS

- 0 = Standard
- A = Low Limit Controls
- B = Phase and Brown Out Protection
- C = Energy Recovery Wheel Defrost
- D = Energy Recovery Wheel Rotation Detection
- E = Compressor Power Factor Correction
- F = Options A + B
- G = Options A + C
- H = Options A + D
- J = Options A + E
- K = Options B + C
- L = Options B + D
- M = Options B + E
- N = Options C + D
- P = Options C + E
- Q = Options D + E
- R = Options A + B + C
- S = Options A + B + D
- T = Options A + B + E
- U = Options A + C + D
- V = Options A + C + E
- W = Options A + D + E
- Y = Options B + C + D
- Z = Options B + C + E
- 1 = Options B + D + E
- 2 = Options C + D + E
- 3 = Options A + B + C + D
- 4 = Options A + B + C + E
- 5 = Options A + B + D + E
- 6 = Options A + C + D + E
- 7 = Options B + C + D + E
- 8 = Options A + B + C + D + E

Feature 13: SPECIAL CONTROLS

- 0 = Terminal Block for Thermostat Control
- D = VAV Unit Controller - VAV Cool + CV Heat
- E = Constant Volume Unit Controller - CV Cool + CV Heat
- F = Makeup Air Unit Controller - CV Cool + CV Heat
- J = Factory Installed DDC Controls Furnished by Others
- K = Factory Installed DDC Controls Furnished by Others w/ Isolation relays
- L = Terminal Block for Thermostat Control with Isolation Relays
- U = Digital Precise Air Controller, D-PAC
- V = Precise Air Controller, PAC
- Y = Single Zone VAV Heat Pump Unit Controller - VAV Cool + VAV Heat
- Z = Constant Volume Heat Pump Unit Controller - CV Cool + CV Heat
- 1 = Makeup Air Heat Pump Unit Controller - CV Cool + CV Heat
- 2 = Single Zone VAV Unit Controller VAV Cool + CV Heat
- 3 = Single Zone VAV Unit Controller VAV Cool + VAV Heat
- 4 = Field Installed DDC Controls by Others
- 5 = Field Installed DDC Controls Furnished by Others with Isolation Relays
- 6 = Factory Installed DDC Controls Furnished by Others with Isolation Relays (SPA)

RN Series Feature String Nomenclature

Model Options : Unit Feature Options

| GEN | SIZE | VLT | CONFIG | A1 | A2 | A3 | A4 | B1 | B2 | B3 | 1A | 1B | 1C | 1D | 2 | 3 | 4 | 5A | 5B | 5C | 6A | 6B | 6C | 7 | 8 | 9 | 10 | 11 | 12 | 13 | 14A | 14B | 15 | 16 | 17 | 18 | 19 | 20 | 21 | 22 | 23 |
|-----|------|-----|--------|----|----|-----|----|----|----|----|----|----|----|----|---|---|----|----|----|------|----|----|----|---|---|---|----|----|----|----|-----|-----|----|----|----|----|----|----|----|----|----|
| RN | -0 | 2 | 5 | -3 | -0 | -BB | 0 | 2 | -3 | 8 | 4 | : | A | 0 | 0 | 0 | -D | 0 | B | -DEH | -0 | BA | -0 | D | 0 | 0 | 0 | 0 | L | -0 | 0 | -0 | 0 | B | 0 | 0 | 0 | 0 | 0 | 0 | B |

Feature 14: PREHEAT

14A: OUTSIDE AIR CONFIGURATION

0 = Standard - None
 A = Steam Distributing Preheat Coil - 1 Row
 B = Steam Distributing Preheat Coil - 2 Row
 C = Hot Water Preheat Coil - 1 Row
 D = Hot Water Preheat Coil - 2 Row
 E = Modulating Electric Preheat
 F = Outside Airflow Monitoring Size A
 G = Outside Airflow Monitoring Size B
 H = Outside Airflow Monitoring Size C
 J = Outside Airflow Monitoring Size D

14B: PREHEAT SIZING

0 = Standard - None
 A = Single Serpentine 8 fpi
 B = Half Serpentine 8 fpi
 C = Single Serpentine 10 fpi
 D = Half Serpentine 10 fpi
 E = Single Serpentine 12 fpi
 F = Half Serpentine 12 fpi
 G = 10 kW (7.5 kW @ 208V)
 H = 15 kW (11.3 kW @ 208V)
 J = 20 kW (15 kW @208V)
 K = 30 kW (22.5 kW @208V)
 L = 40 kW (30 kW @208V)
 M = 50 kW (37.6 kW @208V)
 N = 60 kW (45.1 kW @208V)
 P = 70 kW (52.6 kW @208V)
 Q = 80 kW (60.1 kW @208V)
 R = 90 kW (67.6 kW @208V)
 S = 100 kW (75.1 kW @208V)
 T = 110 kW (82.6 kW @208V)
 U = 120 kW (90.1 kW @208V)

Feature 15: GLYCOL PERCENTAGE

0 = Water or No WSHP, Gas Piped to Exterior
 C = Field Adjustable for Glycol %
 D = Water or No WSHP with Aluminum Energy Recovery Wheel, Gas Piped to Exterior
 E = Field Adjustable Glycol % with Aluminum Energy Recovery Wheel

Feature 16: INTERIOR CABINET OPTIONS

0 = Standard
 B = Control Panel Service Lights
 H = UV Lights
 J = Compressor Sound Blanket (CSB)
 K = Control Panel Service Lights + UV Lights
 L = Control Panel Service Lights + CSB
 M = UV Lights + CSB
 N = Control Panel Service Lights + UV Lights + CSB

Feature 17: EXTERIOR CABINET OPTIONS

0 = Standard
 A = Base Insulation
 B = Burglar Bars
 C = Condenser Coil Guards (or Screen)
 D = Options A + B
 E = Options A + C
 F = Options B + C
 G = Options A + B + C
 H = Motorized Relief Dampers
 J = Options A + H
 K = Options B + H
 L = Options C + H
 M = Options A + B + H
 N = Options A + C + H
 P = Options B + C + H
 Q = Options A + B + C + H

RN Series Feature String Nomenclature

Model Options

:

Unit Feature Options

| | | | | | | | | | | | | | | | | | | | | | | | | | | | | | | | | | | | | | | | | | |
|------|-----|-----------|----|----|----|-----|----|----|----|----|----|----|----|-----|---|---|-------|-----|----|-----|----|----|---|---|---|----|-----|----|-----|-----|-----|----|----|----|----|----|----|----|----|----|---|
| SIZE | VLT | CONFIG | A1 | A2 | A3 | A4 | B1 | B2 | B3 | 1A | 1B | 1C | 1D | 2 | 3 | 4 | 5A | 5B | 5C | 6A | 6B | 6C | 7 | 8 | 9 | 10 | 11 | 12 | 13 | 14A | 14B | 15 | 16 | 17 | 18 | 19 | 20 | 21 | 22 | 23 | |
| 2 | 5 | - 3 - 0 - | BB | 0 | 2 | - 3 | 8 | 4 | : | A | 0 | 0 | 0 | - D | 0 | B | - DEH | - 0 | BA | - 0 | D | 0 | 0 | 0 | 0 | L | - 0 | 0 | - 0 | 0 | 0 | B | 0 | 0 | 0 | 0 | 0 | 0 | 0 | 0 | B |

Feature 18: ELECTRICAL RATING

- 0 = Standard - 5 kAIC
- 1 = 10 kAIC
- 2 = 35 kAIC
- 3 = 65 kAIC

Feature 19: CODE OPTIONS

- 0 = Standard - ETL U.S.A. Listing
- B = Chicago - Cool + Gas
- C = Chicago - Cool + Electric Heat
- D = Chicago - Cool Only
- E = Chicago - Gas Only
- F = Chicago - Electric Heat Only
- G = Chicago - No Cool + No Heat
- H = ETL U.S.A. + Canada Listing
- K = California OSHPD Certification
- L = Shake Table Cert. (ASCE 7-05/ICC-ES AC 156)
- M = Seismic Construction (Non-Certified)
- N = California OSHPD Certification + Chicago
- P = Shake Table Cert. (ASCE 7-05/ICC-ES AC 156) + Chicago
- Q = Seismic Construction (Non-Certified) + Chicago

Feature 20: CRATING

- 0 = Standard
- A = Export Crating
- B = Export Crating - No Condenser Section
- C = Shrink Wrap
- D = Options A + C
- E = Options B + C

Feature 21: WATER-COOLED CONDENSER

- 0 = Standard - None
- A = Balancing Valves
- B = Water Flow Switch
- C = Motorized Shut-off Valve
- D = Head Pressure Control Valve
- E = Options A + B
- F = Options A + C
- G = Options A + D
- H = Options B + C
- J = Options B + D
- L = Options A + B + C
- M = Options A + B + D

Feature 22: CONTROL VENDORS

- 0 = None
- T = VCB-X Controls System + Integrated BACnet MSTP
- U = VCB-X Controls System + Integrated BACnet MSTP with Specials
- V = VCC-X Controls System + Integrated BACnet MSTP
- W = VCC-X Controls System + Integrated BACnet MSTP with Specials
- Y = Remote Mounted AAON Touchscreen Controller
- Z = VCC-X w/BACnet MSTP & Split System
- 1 = VCC-X w/BACnet MSTP w/Specials & Split System

Feature 23: TYPE

- B = Standard - AAON Gray Paint
- U = Special Pricing Authorization + Special Paint
- X = Special Pricing Authorization + AAON Gray Paint
- 1 = Standard Paint + 2 Year Parts Only Warranty (Begins at Date of Shipment)
- 4 = Standard Paint + 5 Year Parts Only Warranty (Begins at Date of Shipment)
- 9 = Standard Paint + 10 Year Parts Only Warranty (Begins at Date of Shipment)

General Information

RN Series packaged rooftop units, heat pumps and outdoor air handling units have been designed for outdoor installation only. Units are assembled, wired, charged and run tested at the factory.

Startup and service must be performed by a Factory Trained Service Technician.

WARNING

Improper installation, adjustment, alteration, service, or maintenance can cause property damage, personal injury or loss of life. Startup and service must be performed by a Factory Trained Service Technician. A copy of this IOM must be kept with the unit.

CAUTION

These units must not be used for heating or cooling at any time during any phase of construction. Very low return air temperatures, harmful vapors, and misplacement of the filters will damage the unit and its efficiency.

Certification of Gas Heat Models

- a. AAON gas heat exchangers have successfully completed 10,000 burner operation cycles and corrosion resistance as specified per test standard ANSI 21.47. All gas heat exchangers used in AAON appliances are certified for use downstream of evaporator or cooling coils.
- b. Certified as a Category III forced air furnace with or without cooling.
- c. Certified for outdoor installation only.

- d. Certified for installation on a combustible roof with a minimum of 30.5cm (12") high curb.

Certification of Steam or Hot Water Heat Models

- a. Certified as a forced air heating system with or without cooling.
- b. Certified for outdoor installation only.
- c. Certified for installation on a combustible roof with a minimum of 30.5cm (12") high curb.

Certification of Electric Heat Models

- a. Certified as an electric warm air furnace with or without cooling.
- b. Certified for outdoor installation only.
- c. Certified for installation on a combustible roof with a minimum of 30.5cm (12") high curb.

Certification of Cooling Models

- a. Certified as a commercial central air conditioner with or without electrically operated compressors.
- b. Certified for outdoor installation only.
- c. Certified for installation on a combustible roof with a minimum of 30.5cm (12") high curb.
- d. Certified with refrigerant R-410A coils or with chilled water cooling coils.

Codes and Ordinances

RN Series units have been tested and certified, by ETL, in accordance with UL Safety Standard 1995 5th Edition/ CSA C22.2 No. 236, ANSI Safety Standard Z21.47b-2016/CSA 2.3b-2016, and ANSI Safety Standard Z83.8-2016/CSA 2.6-2016.

Size the system in accordance with the American Society of Heating, Refrigeration and Air Conditioning Engineers Handbook.

Installation of RN Series units must conform to the ICC standards of the International Mechanical Code, the International Building Code, and local codes and applicable

amendments. In the absence of local codes installation must conform to the current (United States) National Fuel Gas Code ANSI-Z223.1/NFPA 54 or the current (Canada) National Fuel & Propane Installation Code CSA B149.1 or B149.2, and Mechanical Refrigeration Code CSA B52. All appliances must be electrically grounded in accordance with local codes, or in the absence of local codes, the current National Electric Code, ANSI/NFPA 70 or the current Canadian Electrical Code CSA C22.1.

! CAUTION

The Clean Air Act of 1990 bans the intentional venting of refrigerant as of July 1, 1992. Approved methods of recovery, recycling, or reclaiming must be followed.

! WARNING

Coils and sheet metal surfaces present sharp edges and care must be taken when working with equipment.

! WARNING

Failure to observe the following instructions will result in premature failure of your system and possible voiding of the warranty.

Receiving Unit

When received, check the unit for damage that might have occurred in transit. If damage is found it must be noted on the carrier's freight bill. A request for inspection by carrier's agent must be made in writing at once. Nameplate must be checked to ensure

the correct model sizes and voltages have been received to match the job requirements.

If repairs must be made to damaged goods, notify the factory before any repair action is taken in order to protect the warranty. Certain equipment alteration, repair, and manipulation of equipment without the manufacturer's consent may void the product warranty. Contact the AAON Warranty Department for assistance with handling damaged goods, repairs, and freight claims: (918) 382-6450.

Note: Upon receipt check shipment for items that ship loose such as filters and remote sensors. Consult order and shipment documentation to identify potential loose-shipped items. Loose-shipped items may have been placed inside unit cabinet for security. Installers and owners must secure all doors with locks or nuts and bolts to prevent unauthorized access.

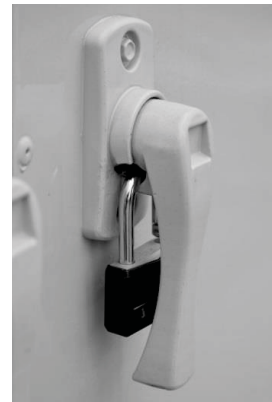

Figure 1 – Lockable Handle

Storage

If installation will not occur immediately following delivery, store equipment in a dry protected area away from construction traffic and in the proper orientation as marked on the packaging with all internal packaging in place. Secure all loose-shipped items.

Wiring Diagrams

Unit specific wiring diagrams are laminated and affixed inside the controls compartment door.

Installation

AAON equipment has been designed for quick and easy installation.

Locating Units

The curb must be mounted first and must be located so that duct connections will be clear of structural members of the building.

Verify rooftop or foundation can support the total unit weight, including accessory weights.

| |
|--|
|  WARNING |
| When locating gas fired units, it is recommended the unit be installed so that the flue discharge vents are located at least 305 cm (120 inches) away from any opening through which combustion products could enter the building. |

| |
|--|
|  WARNING |
| Distances from adjacent public walkways, adjacent buildings, operable windows and building openings, shall conform to local codes and/or the National Fuel Gas Code, ANSI Z223.1/NFPA 54, or the National Gas & Propane Code, CSA B149.1 |

Do not position flue opening to discharge into a fresh air intake of any other piece of equipment. Unit must also be installed so that

the flow of combustion intake air is not obstructed from reaching the furnace.

Vent opening must not be blocked by snow. A minimum 12" curb must be used or the vent outlet shall be greater than 12" off the ground/roof.

Flue gas is dangerously hot and contains contaminants. The user is responsible for determining if vent gases may degrade building materials.

The National Gas and Propane Installation Code, B149.1 specifies a 1.8 m (6 ft.) horizontal vent terminal clearance to gas and electric meters and relief devices.

Local codes may supersede or further place restrictions on vent termination locations.

Table 1- A Cabinet Unit Clearances

| Location | Unit Size |
|---|-----------------|
| | 6-8 and 10 tons |
| Front - (Controls Side) | 122cm (48") |
| Back - (Outside Air) | 91.4cm (36") |
| *Left Side | *15.2cm (6") |
| Right Side | 122cm (48") |
| Top | Unobstructed |
| *Units with a water-cooled condenser or chilled water coil require 122cm (48") of clearance on the left side for service access. DX and no cooling air handling units with an energy recovery wheel require 61 cm (24") of clearance on the left side for service access. | |

Table 2 - B Cabinet Unit Clearances

| Location | Unit Size |
|--|------------------|
| | 9 and 11-15 tons |
| Front - (Controls Side) | 122cm (48") |
| Back - (Outside Air) | 122cm (48") |
| *Left Side | *15.2cm (6") |
| Right Side | 122cm (48") |
| Top | Unobstructed |
| *Units with a water-cooled condenser or chilled water coil require 122cm (48") of clearance on the left side for service access. DX and no cooling air handling units with an energy recovery wheel require 61cm (24") of clearance on the left side for service access. | |

Table 3- C Cabinet Unit Clearances

| Location | Unit Size |
|--|-------------------|
| | 16-25 and 30 tons |
| Front - (Controls Side) | 122cm (48") |
| Back - (Outside Air) | 122cm (48") |
| *Left Side | *15.2cm (6") |
| Right Side | 152cm (60") |
| Top | Unobstructed |
| *Units with a water-cooled condenser or chilled water coil require 122cm (48") of clearance on the left side for service access. | |



Figure 2- RN Series A, B and C Cabinet, 6-25 and 30 tons

Setting the Curb

Make openings in roof decking large enough to allow for duct penetration and workspace only. Do not make openings larger than necessary. Set the curb to coincide with the openings. Make sure the curb is level. Unit must be level in both horizontal axes to support the unit and reduce noise and vibration.

! CAUTION

All roofing work must be performed by competent roofing contractors to avoid any possible leakage.

! CAUTION

Where the supply or warm air duct passes through a combustible roof, a clearance of 2.5 cm (1 inch) must be maintained between the outside edges of the duct and combustible material in accordance with National Fire Protection Association Standard No. 90A. Provide flashings or enclosure between structure and roof and all joints must be sealed with mastic roofing to ensure a watertight seal.

Be careful to install the provided neoprene isolator according to the following figure prior to setting the unit on

! CAUTION

Neoprene isolator for unit vibration isolation is provided in the cabinet and must be installed according to installation manual.

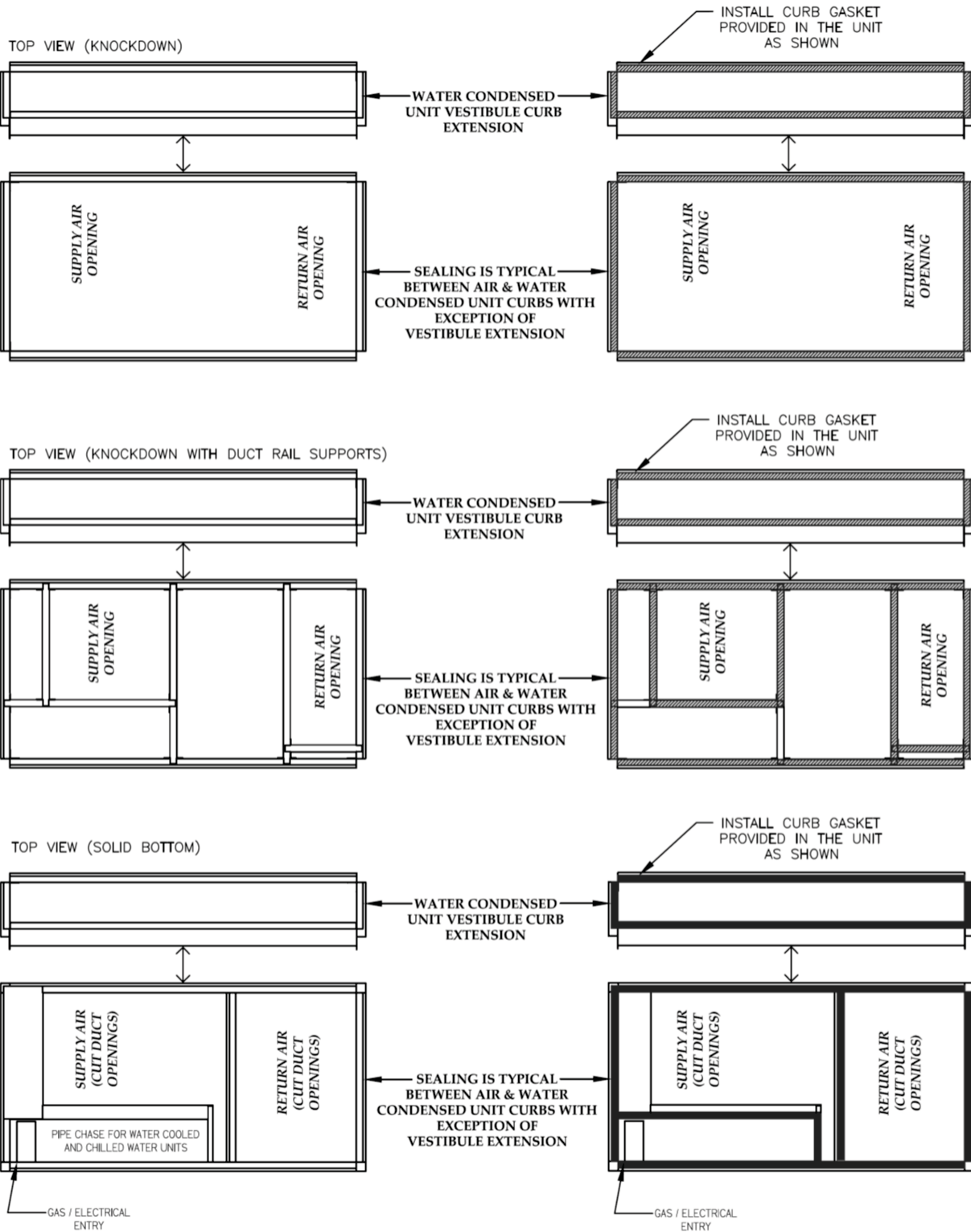

Figure 3- RN Series 6-8 and 10 ton Unit Isolator Locations

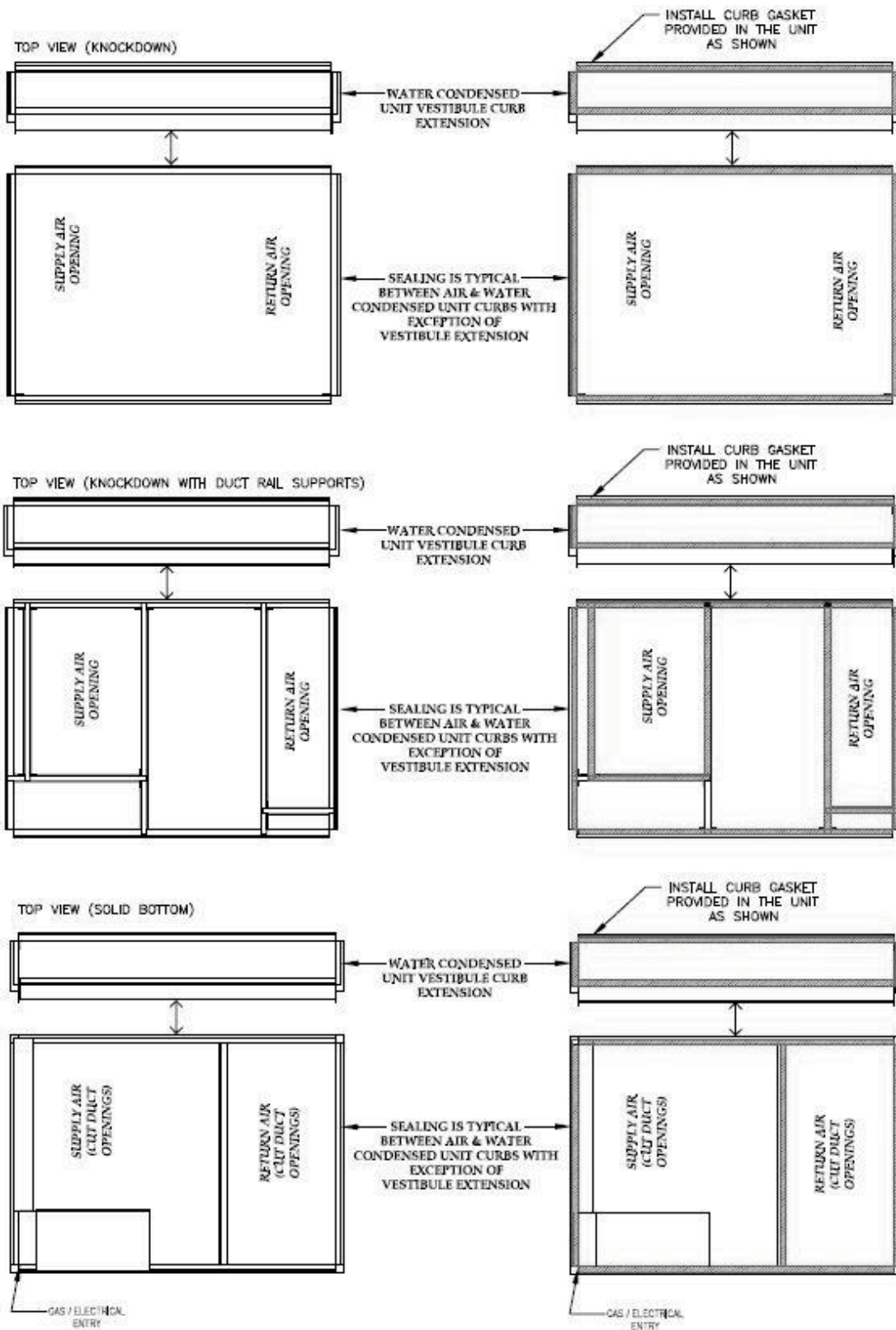

Figure 4- RN Series 9 and 11-15 ton Unit Isolator Locations

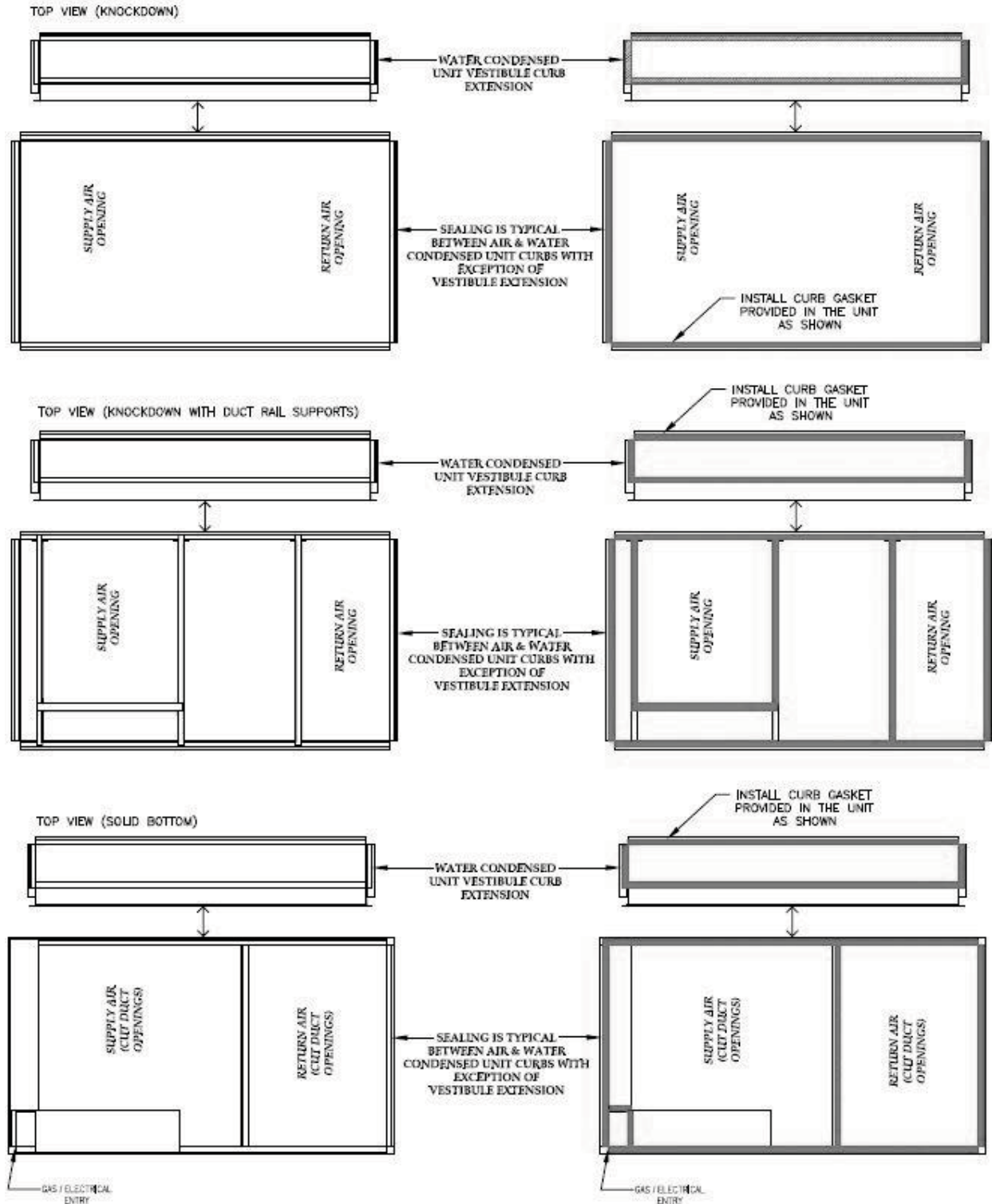
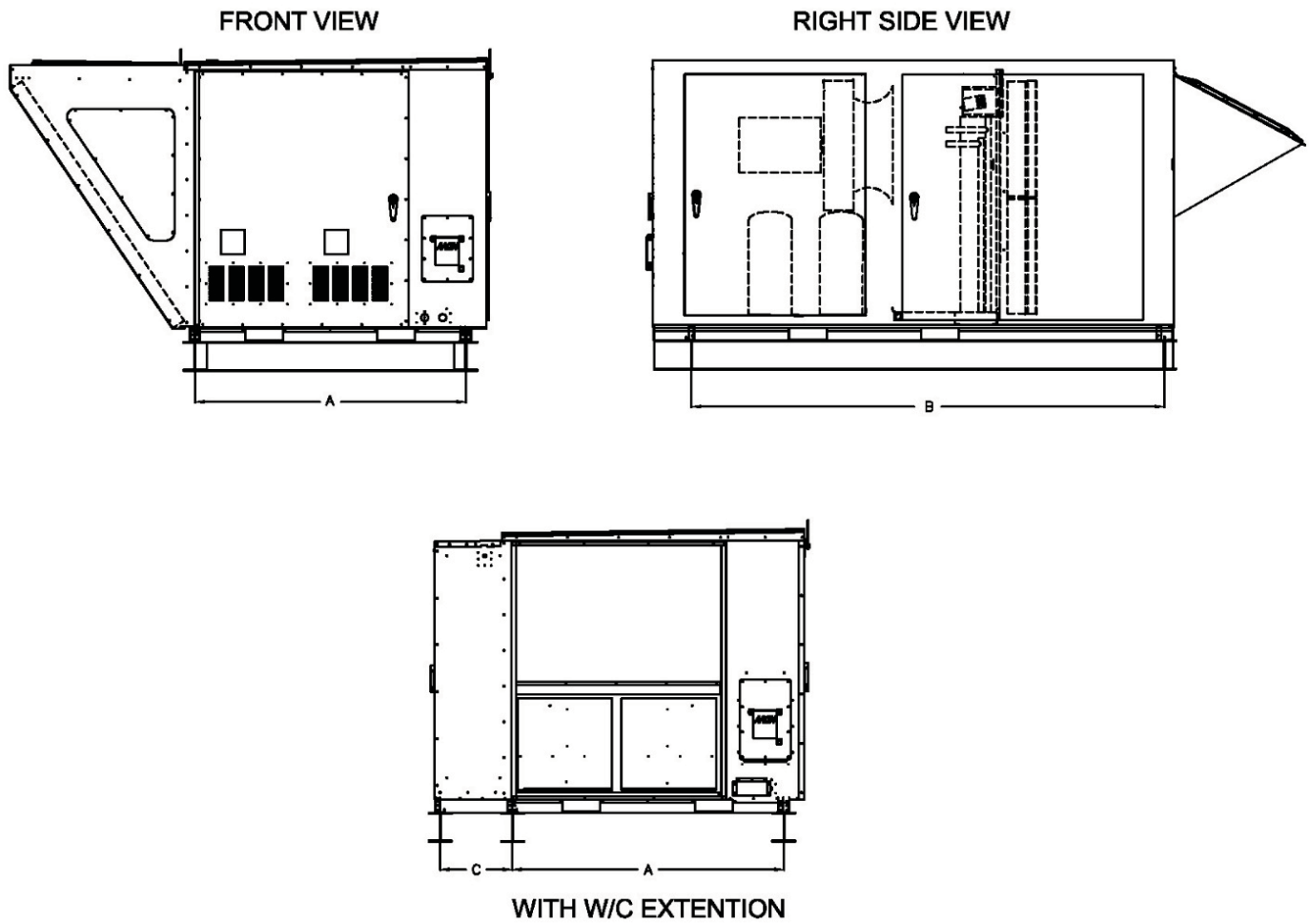

Figure 5- RN Series 16-25 and 30 ton Unit Isolator Locations

RN SERIES STRUCTURAL STEEL ALIGNMENT DETAIL



| TONS | STANDARD | | HEATWHEEL | | WATER COND | | | WC/HW | | | PE/PR | |
|------|------------------|-------------------|------------------|-------------------|------------------|-------------------|------------------|------------------|-------------------|------------------|------------------|-------------------|
| | A | B | A | B | A | B | C | A | B | C | A | B |
| RQ | 42 $\frac{1}{4}$ | 80 $\frac{3}{8}$ | 42 $\frac{1}{8}$ | 114 $\frac{1}{4}$ | 42 $\frac{1}{8}$ | 80 $\frac{3}{8}$ | N/A | 42 | 114 $\frac{1}{8}$ | N/A | N/A | N/A |
| RNA | 42 $\frac{1}{4}$ | 80 $\frac{3}{8}$ | 42 $\frac{1}{8}$ | 114 $\frac{1}{4}$ | 42 $\frac{1}{8}$ | 80 $\frac{3}{8}$ | 13 $\frac{3}{8}$ | 42 | 114 $\frac{1}{8}$ | 13 $\frac{1}{2}$ | N/A | N/A |
| RNB | 56 $\frac{7}{8}$ | 79 $\frac{1}{2}$ | 56 $\frac{3}{4}$ | 119 $\frac{1}{4}$ | 56 $\frac{3}{4}$ | 79 $\frac{1}{8}$ | 13 $\frac{1}{2}$ | 56 $\frac{3}{4}$ | 119 $\frac{1}{4}$ | 13 $\frac{3}{8}$ | N/A | N/A |
| RNC | 57 $\frac{3}{8}$ | 100 $\frac{1}{8}$ | 57 $\frac{3}{8}$ | 148 $\frac{5}{8}$ | 57 $\frac{3}{8}$ | 100 $\frac{1}{8}$ | 15 $\frac{1}{4}$ | 57 $\frac{3}{8}$ | 148 $\frac{5}{8}$ | 15 $\frac{3}{8}$ | 57 $\frac{3}{8}$ | 148 $\frac{7}{8}$ |
| RND | 98 $\frac{1}{8}$ | 151 $\frac{1}{8}$ | 98 $\frac{1}{4}$ | 199 $\frac{3}{4}$ | 98 $\frac{1}{8}$ | 151 $\frac{1}{2}$ | N/A | 98 $\frac{1}{4}$ | 199 $\frac{3}{4}$ | N/A | 98 $\frac{1}{8}$ | 199 $\frac{3}{4}$ |

*DIMENSION TOLERANCE
+/- $\frac{1}{4}$

NOTE: ALL DIMENSIONS ARE IN INCHES
SPECIAL 06/10/14 MLW

Figure 6 - Steel Mounting

! CAUTION

Incorrect lifting can cause damage to the unit.

Forklifting the Unit (6-25 and 30 ton)

6-25 and 30 ton units can be lifted using a forklift. 9, 11-25 and 30 ton units must have forks 1.8 m (72") in length or the forks must have 1.8 m (72") fork extensions. 6-8 and 10 ton units must have forks at least 1.2 m (48") in length. Standard units can be lifted from all sides except the condenser side. Units with power exhaust can be lifted from the controls side or the access (right) side. Units with energy recovery wheels or power return can only be fork lifted from the access (right) side.

! CAUTION

**FORKLIFTING
9, 11-25 AND 30 TON UNITS**

Forks or Fork Extensions must be 1.8 m (72") in length.

! CAUTION

**FORKLIFTING
6-8 AND 10 TON UNITS**

Forks or Fork Extensions must be at least 122cm (48") in length.

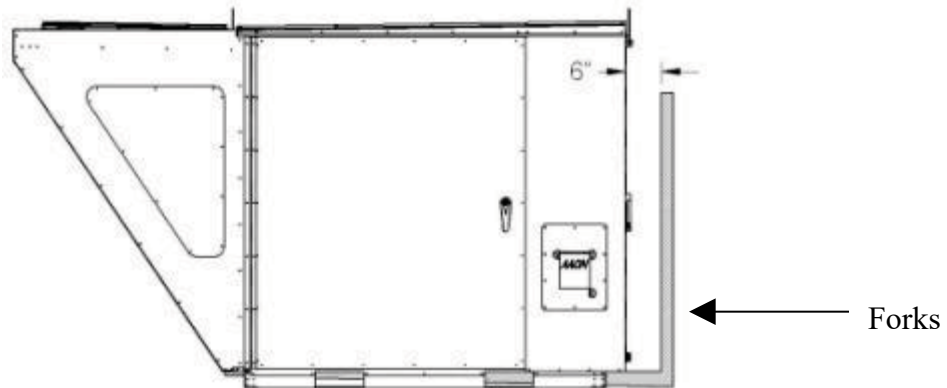

Figure 7 - Forklifting an RN Series A, B and C Cabinet, 6-25 and 30 tons

Lifting the Unit

If cables or chains are used to hoist the unit they must be the same length. Minimum cable length is 2.5 m (99") for 6-25 and 30 ton units.

Care must be taken to prevent damage to the cabinet, coils, and condenser fans.

It is recommended to lift the unit with the outside air hood in the downward shipping position. However, the unit may be lifted with the outside air hood in the open position.

Before lifting unit, be sure that all shipping material has been removed from unit. Secure hooks and cables at all lifting points / lugs provided on the unit.

Hoist unit to a point directly above the curb and duct openings. Be sure that the gasket material has been applied to curb.

Carefully lower and align the unit with utility and duct openings. Lower the unit until the unit skirt fits around the curb. Some units are designed to overhang the curb. Take care that any recessed base rails fit around the curb. Make sure the unit is properly seated on the curb and is level.

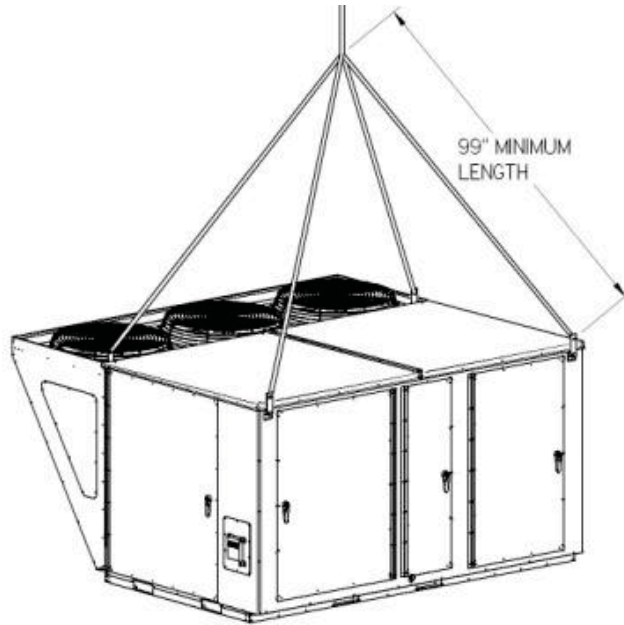



Figure 8 - Lifting Details of a 6-25 and 30 ton Standard or Power Exhaust Unit



Figure 9 - Lifting Details of a 6-25 and 30 ton Energy Recovery Wheel or Power Return Unit

Duct Connection

Note: If outside air will be in contact with the air tunnel base of an A, B or C cabinet unit (6-25 and 30 tons), the unit must include the base insulation option or the base must be field insulated.

CAUTION

Do not drill or punch holes in the base of the unit, from inside the unit or from below the unit to attach ductwork. Leaking may occur if unit base is punctured.

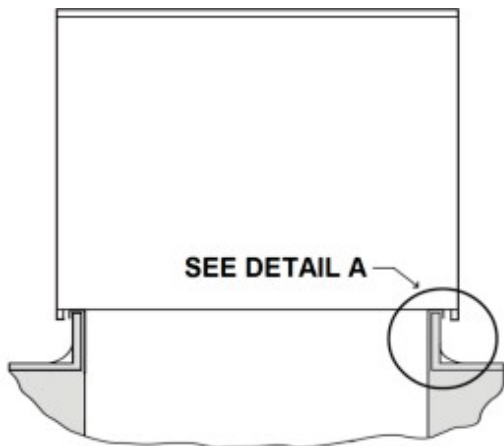

SECTIONAL VIEW OF UNIT ON ROOF CURB

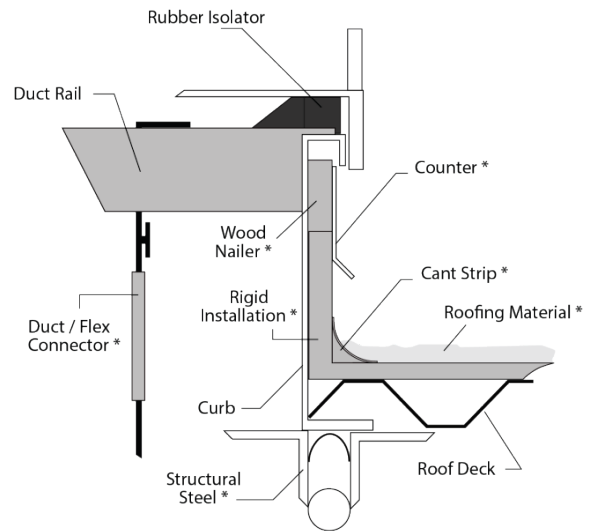

Detail A

Knock Down Curb
Duct Support Rail Connection
* Field Supplied

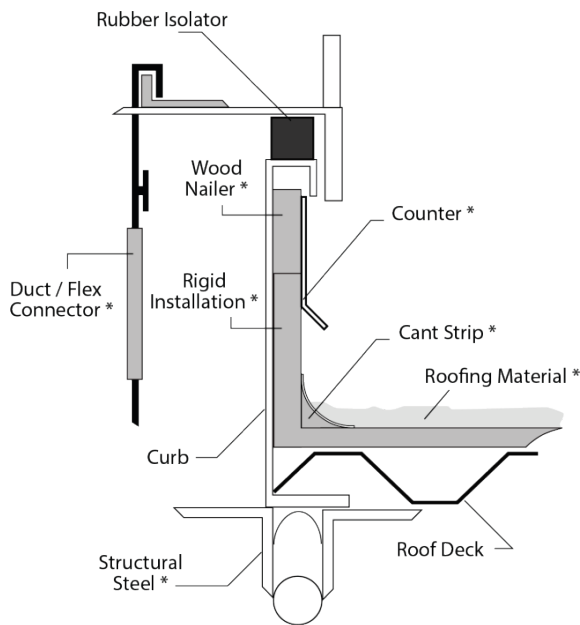

Detail A

Unit Base Connection
* Field Supplied

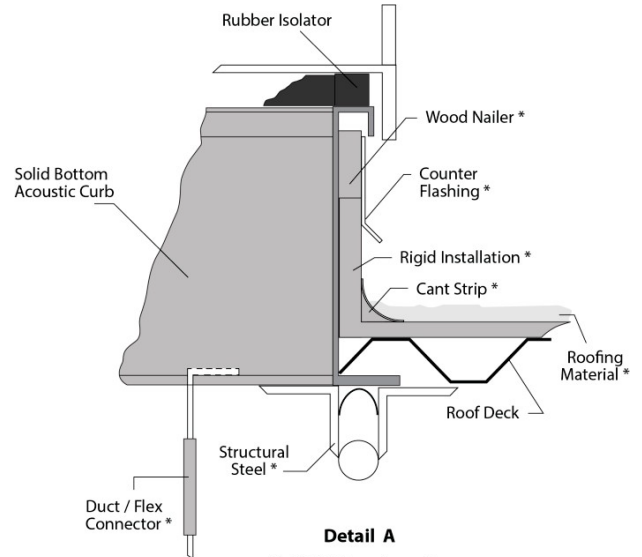

Detail A

Solid Bottom Acoustic Curb Duct Connection
* Field Supplied

Figure 10 - Duct Connection

Seismic Curb Installation

Using a standard curb with a seismic unit will void the certification of the unit. All mounting details listed must be followed to achieve seismic certification. The AAON unit must be certified to ICC-ES AC156 when using a seismic curb for seismic certifications to apply. Any deviations or

modifications to the unit or curb will void all seismic certification.

Structural engineer of record must approve field provided building anchorage to unit or curb in compliance with OSP-0180-10. Use provided self tapping screws to attach base of unit to seismic curb bracket.

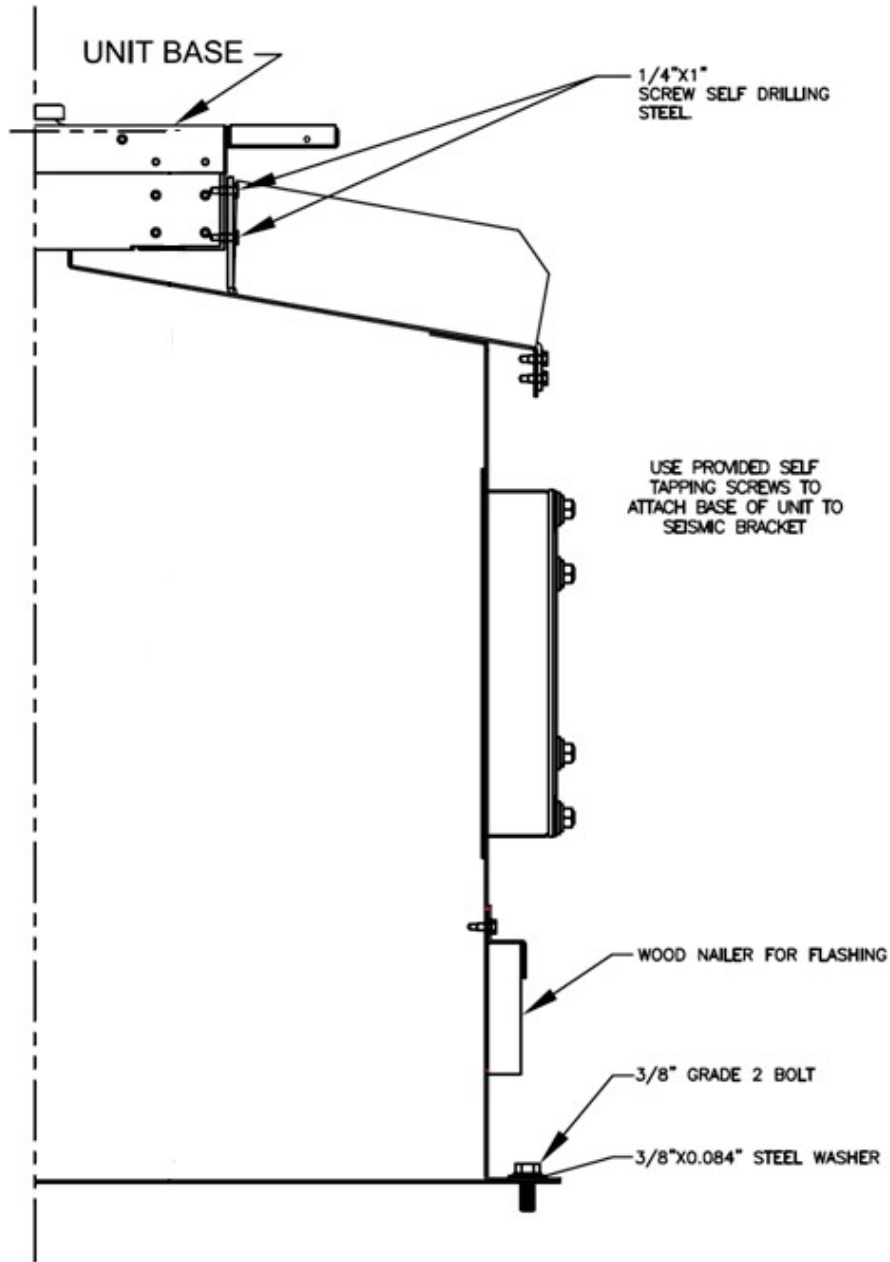

Figure 11 - Solid Bottom Seismic Curb with Filters

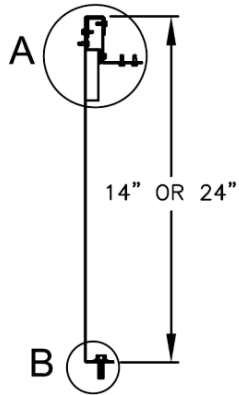
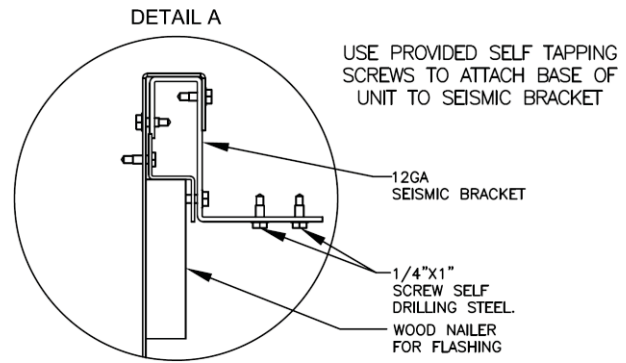
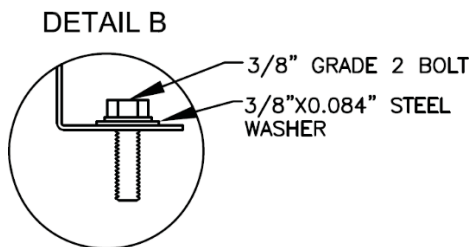

Figure 12 - Seismic Solid Bottom Curb without Filters Cross Section



Seismic Solid Bottom Curb without Filters
Detail A



Seismic Solid Bottom Curb without Filters Detail B

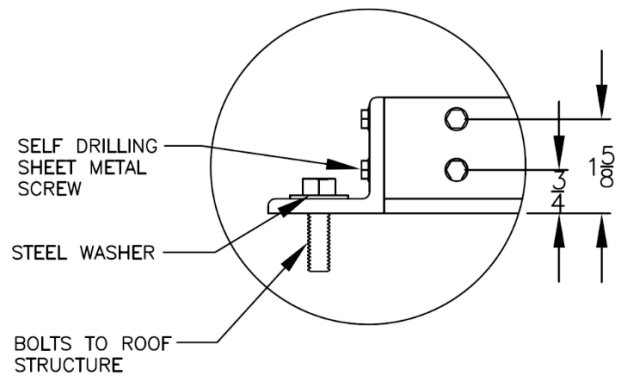

RIGID MOUNT ANGLE
CROSS SECTION
Seismic Rigid Mount Curb

Outside Air Rain Hood

Rain hood must be opened before startup of the unit. Fresh air intake adjustments must be made according to building ventilation of local code requirements.

6-25 and 30 ton Units

Remove the two screws at the bottom of the rain hood that secure it in the shipping position. Remove the screws that attach the side pieces of the hood to the top of the hood.

Rotate the side pieces so that the holes along one edge line up with the holes on the top piece and the flange is on the inside of the rain hood.

Attach the side pieces to the top of the hood using the provided screws and attached the side pieces to the end of the unit through the flange.

Apply silicon caulking along the top and both sides of the rain hood. Take care to seal the top corners where the rain hood attaches to the unit.

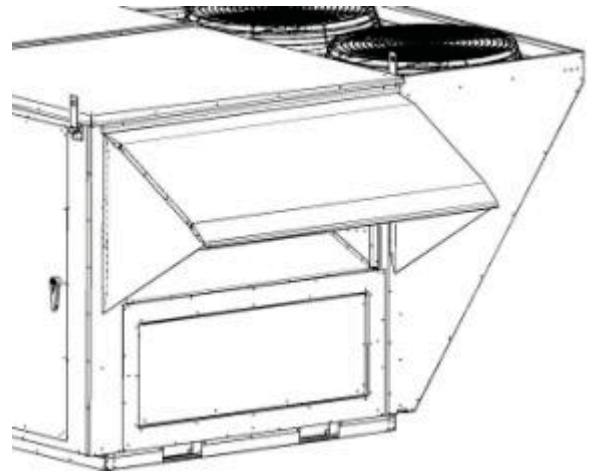

Figure 22 - 6-25 and 30 ton
Open Rain Hood

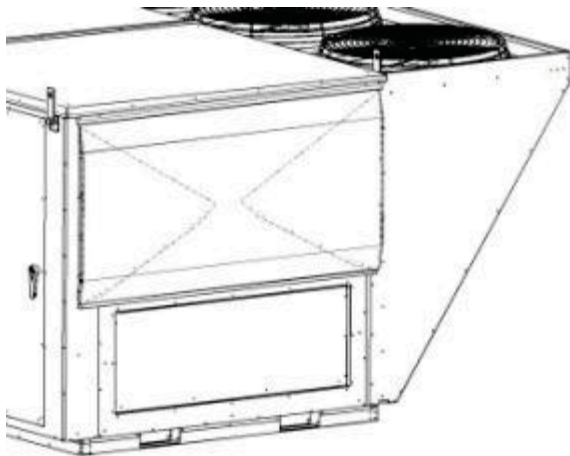

Figure 13 - 6-25 and 30 ton Closed Rain Hood

Metal Mesh Filters (6-25 and 30 ton Units)

Metal mesh outside air filters require installation of the filter rack on the intake of the rain hood.

Clips which hold the metal mesh filters in the filter rack face outward.

! CAUTION

In order to prevent water leakage into the roof curb, the factory provided sheet metal flashings **MUST BE** attached to the unit base to cover the shipping slots at both ends of the unit.

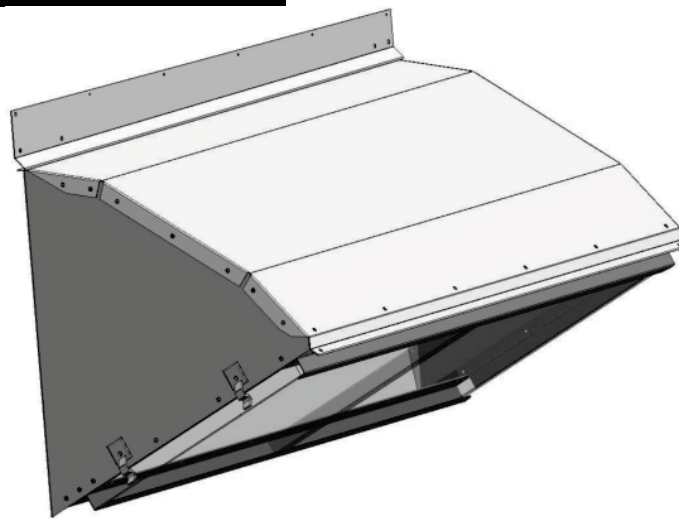

Figure 14 - Rain Hood with Metal Mesh Filter Rack Installation

Electrical

Verify the unit nameplate agrees with power supply. Connect power and control wiring to the unit as shown in Figure 27 and Figure 28, and in the unit specific wiring diagram, which shows factory and field wiring and is attached to the inside of the door of the controls compartment.

Table 4 - Nameplate Voltage Markings & Tolerances

| Hz | Nameplate Voltage | Nominal System Voltage | Operating Voltage Range ¹ | | Acceptable Performance Range ² | |
|----|-------------------|------------------------|--------------------------------------|-----|---|-----|
| | | | Min | Max | Min | Max |
| 60 | 115 | 120 | 104 | 127 | 108 | 126 |
| | 208/230 | 208/240 | 187 | 254 | 187 | 252 |
| | 208 | 208 | 187 | 228 | 187 | 228 |
| | 230 | 240 | 208 | 254 | 216 | 252 |
| | 265 | 277 | 240 | 293 | 249 | 291 |
| | 460 | 480 | 416 | 508 | 432 | 504 |
| | 575 | 600 | 520 | 635 | 540 | 630 |
| 50 | 230 | 230 | 198 | 254 | 208 | 254 |
| | 400 | 400 | 344 | 440 | 360 | 440 |

Notes:

1. Operating voltage is the min and max voltage for which the unit can function. Never operate outside of this min and max voltage.
2. The Acceptable Performance Range is the min and max voltage for which the unit performance is designed and rated to give acceptable performance.

Route power and control wiring, separately, through the utility entry in the base of the unit. Do not run power and signal wires in the same conduit.

The utility entry on 9-25 and 30 ton units is located in the unit base in the front right hand corner of the unit (compressor compartment)..

WARNING

Electric shock hazard. Before attempting to perform any installation, service, or maintenance, shut off all electrical power to the unit at the disconnect switches. Unit may have multiple power supplies. Failure to disconnect power could result in dangerous operation, serious injury, death, or property damage.

CAUTION

Proper sealing of the electrical and gas entries into the unit must be performed. Failure to seal the entries may result in damage to the unit and property.

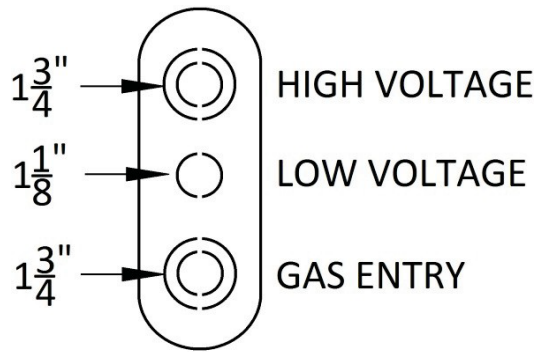

| | |
|----------------------------|----------------------------|
| $1\frac{3}{4}$ " = 44.5 mm | $1\frac{1}{8}$ " = 28.5 mm |
|----------------------------|----------------------------|

Figure 15 - Unit Utility Entry

Note: All units are factory wired for 208V, 230V, 380V, 460V, or 575V. The transformer configuration must be checked by a qualified technician prior to service, especially if unit is to be connected to a 208V or 230V supply. For 208V service interchange the yellow and red conductor on the low voltage control transformer.

Red-Black for 208V

Yellow-Black for 230V

Wire power leads to the unit's terminal block or main disconnect. All wiring beyond this point has been completed by the manufacturer and cannot be modified without effecting the unit's agency/safety certification.

Supply voltage must be within the min/max range shown on the unit nameplate. Available short circuit current must not exceed the short circuit current rating (SCCR) shown on the unit nameplate.

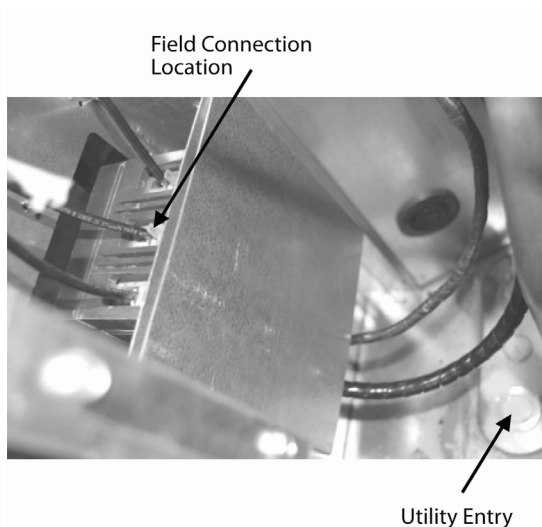

Figure 16 - Back View of Power Switch from Compressor and Control Compartment (6-30 Units)

Size supply conductors based on the unit MCA rating. Supply conductors must be rated a minimum of 75°C (167°F).

Protect the branch circuit in accordance with code requirements. The unit must be electrically grounded in accordance with local codes, or in the absence of local codes, the current National Electric Code, ANSI/NFPA 70 or the current Canadian Electrical Code CSA C22.1.

! CAUTION

Three phase voltage imbalance will cause motor overheating and premature failure.

Three phase voltage imbalance will cause motor overheating and premature failure. The maximum allowable imbalance is 2%.

Voltage imbalance is defined as 100 times the maximum deviation from the average voltage divided by the average voltage.

Example:
 $(221V+230V+227V)/3 = 226V$, then
 $100*(226V-221V)/226V = 2.2\%$, which exceeds the allowable imbalance.

Check voltage imbalance at the unit disconnect switch and at the compressor terminal. Contact your local power company for line voltage corrections.

It must be verified that proper motor rotation and blower motor amperage listed on the motor nameplate is not exceeded. Motor overload protection may be a function of the variable frequency drive and must not be bypassed.

! CAUTION

Rotation must be checked on all MOTORS AND COMPRESSORS of three phase units. Supply fan, exhaust fan, return fan, and condenser fan motors must all be checked by a qualified service technician at startup and any wiring alteration must only be made at the unit power connection.

! CAUTION

All compressors are directional and will be damaged by operation in the wrong direction. Low pressure switches on compressors have been disconnected after factory testing. Rotation must be checked by a qualified service technician at startup using suction and discharge pressure gauges and any wiring alteration must only be made at the unit power connection.

Wire control signals to the unit's low voltage terminal block located in the controls compartment.

Fuses and Circuit Breakers

The interrupting rating of fuses and circuit breakers is to be determined based on the KAIC rating of the unit. Refer to the wiring diagram for fuse sizing.

Table 5 – 35 KAIC Fuse Sizing

| 35 KAIC Construction | | |
|----------------------|----------------------------|--------------------------|
| Component | Description | Interrupting Rating (kA) |
| Fuse | Class CC, 600V, 0.5A - 30A | 200 |
| Fuse | Class J, 600V, 35A - 600A | 200 |
| Disconnect | 3P, 600V, 15A - 600A | 35 |

Table 6 – 65 KAIC Fuse Sizing

| 65 KAIC Construction | | |
|----------------------|----------------------------|--------------------------|
| Component | Description | Interrupting Rating (kA) |
| Fuse | Class CC, 600V, 0.5A - 30A | 200 |
| Fuse | Class J, 600V, 35A - 600A | 200 |
| Disconnect | 3P, 600V, 15A - 600A | 65 |

Variable Speed Compressors

Variable speed compressors with VFD speed control are available on 7-13, 15, 16, 20, 25, And 30 ton units. Variable speed compressors must not be operated outside the factory determined turndown ratio or frequency range. The factory determined compressor VFD ranges are given in the following tables.

Table 7 - RN-A through C Cabinet Variable Speed Compressor Turndown Ratio

| <i>Model (RN-)</i> | <i>Compressor Turndown Ratio</i> |
|--------------------|----------------------------------|
| 007 | 17% |
| 008 | 15% |
| 009 | 10% |
| 010 | 20% |
| 011 | 10% |
| 013 | 10% |
| 015 | 12% |
| 016 | 20% |
| 020 | 12% |
| 025 | 15% |
| 030 | 15% |

CAUTION

Variable speed compressors shall not operate below 35 Hz. Operating variable speed compressors outside the frequency range specified in this manual voids all warranties and may result in compressor failure.

Thermostat Control Wiring

If a thermostat is used for unit control, locate the thermostat on an inside wall 1.2-1.5 meters (4-5 feet) above the floor where it will not be subjected to drafts, sun exposure, or heat from electrical fixtures of appliances. Control wiring must deliver adequate voltage to components to assure proper operation. Control voltage returning from controller circuit must be a minimum of 21 VAC. To assure proper wiring use the following chart to determine the allowable wiring distances.

Table 8 - Control Wiring

| Wire Size (Stranded) - Copper Conductors Only | Total Wire Distance Allowable | |
|---|-------------------------------|---------|
| 20 AWG | 60.96 m | 200 ft |
| 18 AWG | 106.7 m | 350 ft |
| 16 AWG | 152.4 m | 500 ft |
| 14 AWG | 228.6 m | 750 ft |
| 12 AWG | 381.0 m | 1250 ft |

Total Wire Distance Allowable =
(Quantity of Control Wires) x
(Control Wire Distance)

Take the total wire distance allowable and divide by the quantity of wires to be connected. This indicates the distance allowable for that size wire. The wiring to the unit must not exceed the total wire distance allowable. If the voltage at the connectors is less than 21 VAC, isolation relays must be installed. If under external control 21 VAC must be field verified.

All external devices must be powered via a separate external power supply.

Example:

A total of 8 wires must be pulled 75ft to a control the unit. What size wire must be used?

According to the Table 10, 16 AWG allows for 63ft (500 ft/8 wires) and 14 AWG allows for 94ft (750 ft/8 wires). Thus, 14 AWG must be used.

Condensate Drain Piping

6-25 and 30 ton units are equipped with one condensate drain pan connection on the right side of the unit. P-traps must be field provided and installed.

All drain connections must be used and individually trapped to ensure a minimum amount of condensate accumulation in the drain pans. Use ABS type cement to join the drain pipe connections.

Note: The drain pan connections are 25mm (1") MPT fitting for 6-30 (A- C Cabinet sizes).

Drainage of condensate directly onto the roof may be acceptable in certain areas, refer to local codes. If condensate is to drain directly onto the roof, place a small drip pad below the drain to protect the roof from possible damage.

If condensate is piped into the building drainage system, the drain pipe must penetrate the roof external to the unit itself. The drain line must be pitched away from the unit at least 3.2mm (1/8 inch) per meter (foot). On longer runs an air break must be used to ensure proper drainage.



CAUTION

Unit must not be operated without a p-trap. Failure to install a p-trap may result in overflow of condensate water into the unit.

Draw-through cooling coils will have a negative static pressure in the drain pan area. This will cause an un-trapped drain to back up due to air being pulled up through the condensate drain piping.

Condensate drain trapping and piping must conform to all applicable governing codes.

Draw-Through Coils

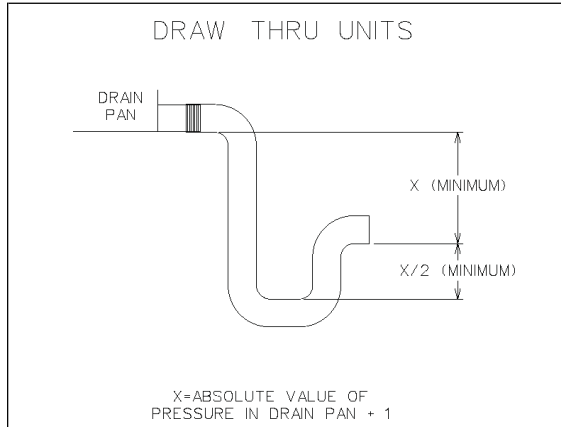

Figure 17 - Draw-Through Drain Trap

The X dimension on the draw-through trap must be at least equal to the absolute value of the negative static pressure in the drain pan plus one inch. To calculate the static pressure at the drain pan add the pressure drops of all components upstream of the drain pan, including the cooling coil, and add the return duct static pressure. Include the dirt allowance pressure drop for the filters to account for the worst-case scenario.

The height from top of the bottom bend of the trap to the bottom of the leaving pipe must be at least equal to one half of the X dimension. This ensures that enough water is stored in the trap to prevent losing the drain seal during unit startup

Note: The absolute value of the fan inlet pressure will always be greater than or equal to the absolute value of the static pressure in the drain pan on draw-through units, so the fan inlet pressure is a safe value to use for the drain pan static pressure.

Table 9 - Draw-Through Drain Trap Dimensions (Metric)

| Draw-Through | | |
|--------------------|-----------------|---------------|
| Drain Pan Pressure | Trap Dimensions | |
| Negative Static | X | X/2 |
| (mmHg) | (millimeters) | (millimeters) |
| -0.93 | 38.1 | 19.1 |
| -1.87 | 50.8 | 25.4 |
| -2.80 | 63.5 | 31.8 |
| -3.74 | 76.2 | 38.1 |
| -4.67 | 88.9 | 44.5 |
| -5.60 | 101.6 | 50.8 |
| -6.54 | 114.3 | 57.2 |
| -7.47 | 127 | 63.5 |
| -8.41 | 139.7 | 69.9 |
| -9.34 | 152.4 | 76.2 |
| -10.28 | 165.1 | 82.6 |
| -11.21 | 177.8 | 88.9 |
| -12.14 | 190.5 | 95.3 |
| -13.08 | 203.2 | 101.6 |
| -14.01 | 215.9 | 108.0 |
| -14.95 | 228.6 | 114.3 |

Note: 1 mm = 0.1 cm

Table 10 - Draw-Through Drain Trap Dimensions (Imperial)

| Draw-Through | | |
|--------------------|-----------------|--------|
| Drain Pan Pressure | Trap Dimensions | |
| Negative Static | X | X/2 |
| (inches of water) | (inch) | (inch) |
| -0.50 | 1.50 | 0.75 |
| -1.00 | 2.00 | 1.00 |
| -1.50 | 2.50 | 1.25 |
| -2.00 | 3.00 | 1.50 |
| -2.50 | 3.50 | 1.75 |
| -3.00 | 4.00 | 2.00 |
| -3.50 | 4.50 | 2.25 |
| -4.00 | 5.00 | 2.50 |
| -4.50 | 5.50 | 2.75 |
| -5.00 | 6.00 | 3.00 |
| -5.50 | 6.50 | 3.25 |
| -6.00 | 7.00 | 3.50 |
| -6.50 | 7.50 | 3.75 |
| -7.00 | 8.00 | 4.00 |
| -7.50 | 8.50 | 4.25 |
| -8.00 | 9.00 | 4.50 |

! CAUTION

All condensate drains must be trapped individually before they are connected to a common line.

! CAUTION

All condensate drain connections must be used. Drain pans are sloped towards connections.

Startup

(See back of the manual for startup form.)

! WARNING

Improper installation, adjustment, alteration, service or maintenance can cause property damage, personal injury or loss of life. Startup and service must be performed by a Factory Trained Service Technician.

! WARNING

Electric shock hazard. Shut off all electrical power to the unit to avoid shock hazard or injury from rotating parts.

During startup, it is necessary to perform routine checks on the performance of the unit. This includes checking the air flow, air filters, condenser water flow, dampers, heaters, and refrigerant charge.

Filters

Do not operate the unit without filters in place. Check the unit for correct filter placement during startup. Operation of the

equipment without filters will result in a clogged evaporator coil.

Supply Fans

RN Series units are equipped with direct drive backward curved plenum fan assemblies that are selected to deliver the air volume specified according to unit size and job requirements. This is either done with air volume bands in the blower wheels or with variable frequency drives. Field airflow adjustment may be required at startup.

Air volume bands for the wheels are sized according to the unit's air delivery specifications and can also be ordered from the factory for field installation. Wheels come standard with a 10% air volume band, as a safety factor, in case additional air volume is required from the unit.

Air Flow Adjustment

If reduced air volume is required an air volume band or larger air volume band can be installed within the blower wheel to reduce the amount of air delivered by the wheel.

If the unit is factory equipped with the air volume band and additional air volume is required, the band can be removed from the wheel.

Use fan program in AAON ECat to determine the new band size for the required cfm and static pressure.

The following photos of a wheel are provided for practical guidelines only in order to identify the air band location in the wheel. Actual field installation of the air band into the wheel will require access into and through the blower wheel venture, which may require removal of the blower motor and wheel.

Air volume bands are made of aluminum, sized and equipped with easy bend tabs that are to be inserted into pre-punched slots provided on the wheel. Once the band has been inserted into the slots, it **MUST BE** secured by bending the tabs over from the back side of the wheel and also **MUST BE** secured from the inside by connecting the ends together with a pop-riquet in the holes provided on the ends of the band.

If the band is field installed, a hand held pop-riquet tool is recommended for connecting the band ends together. Caution must be taken to assure that the band is tightly installed and no damage, denting or alteration to the wheel or blades occurs during the installation.

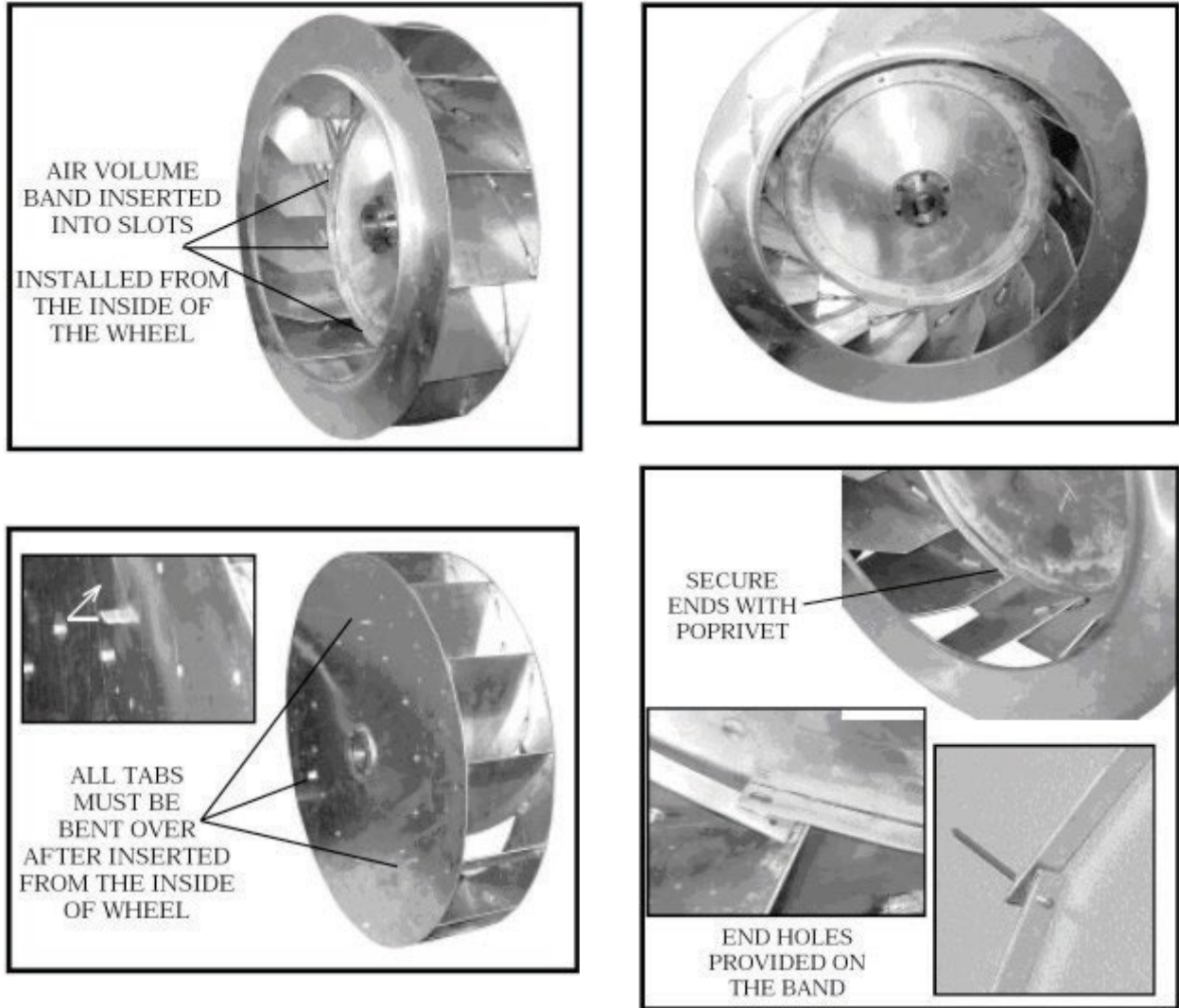

Figure 18 - Supply Fan Banding

For single set screw applications, tighten the set screw to the required torque setting (Table 11) using a calibrated torque wrench. For double set screw applications, tighten one set

screw to half of the required torque setting (Table 11) using a calibrated torque wrench. Tighten the second set screw to the full

required torque setting then tighten the first set screw to the full required torque setting.

Table 11 - Plenum Fan Set Screw Specifications

| SET SCREW DIAMETER | TORQUE (Nm [IN-LBS]) |
|--------------------|----------------------|
| .64 cm (1/4") | 9 [80] |
| .79 cm (5/16") | 14.2 [126] |
| .95 cm (3/8") | 27.12 [240] |

The gap tolerances that are allowed between the blower and the inlet cone for the plenum fan blowers are shown in Figure 31. The inlet cone can be moved as necessary to center the cone in relation to the blower. The blower can be moved on the motor shaft to set the correct overlap. These tolerances are critical to the performance of the blower.

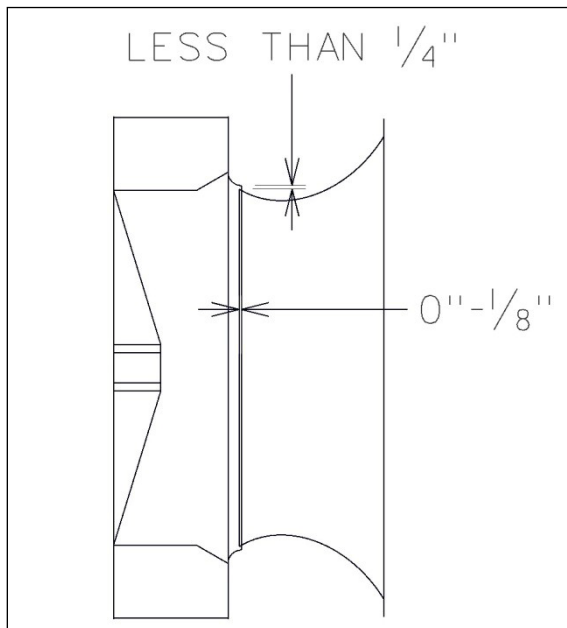

Figure 19 - Plenum Fan Gap Tolerances

Power Return Axial Flow Fans (16-25 and 30 tons)

Blade Pitch Angle Setting Instructions

Step 1: Determine the new required pitch for the fan blades

Use the fan program in AAON ECat.

Step 2: Maintain the balance of fan

Mark the HUB/RET castings across a single joint, so the fan can be reassembled in the same orientation.

Mark the location of any balancing weight. Balancing weight will be on the outer bolt circle, in the form of washers, and/or longer bolts, or an additional balancing nut.

Number the blades and blade sockets, so that they can be replaced into their original positions.

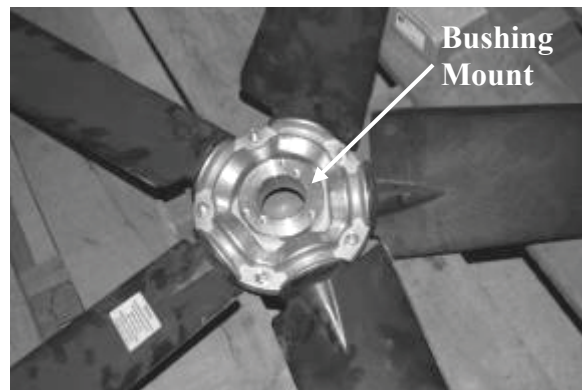

Figure 20 - Fan with the HUB on the Top and RET on the Bottom

Step 3: Determine the direction of rotation
Right, R, is clockwise when facing the discharge side of the fan and Left, L, is counterclockwise when facing the discharge side of the fan.

Step 4: Determine the bushing mount location

The bushing mount is the center section of the hub through which the fan is mounted to the shaft, and typically contains either setscrews or a center-tapered hole where the bushing inserts.

Location A is with the bushing mount on air inlet side of the fan.

Location B is with the bushing mount on air discharge side of the fan.

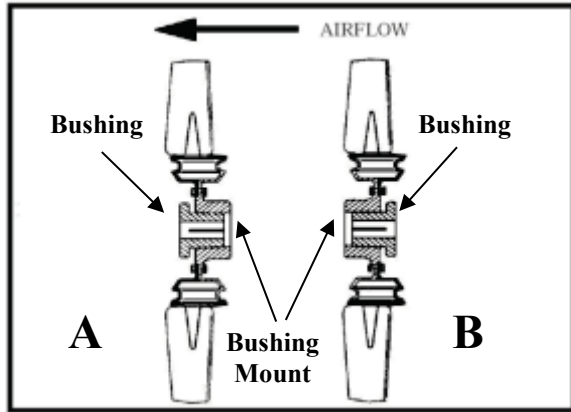

Figure 21 - Bushing Mount Location

Step 5: Determine the pin location groove
 Disassemble fan on a flat surface and note in which groove the pin is located.

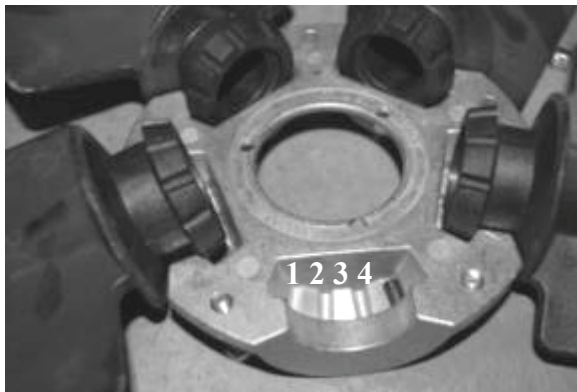
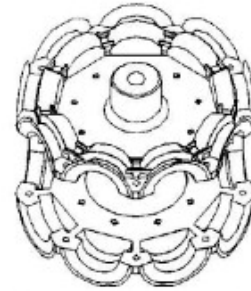

Figure 22 - RET with Pin in Groove 4

Step 6: Determine whether the pin is in the HUB or RET



Top half is the HUB.
 Bottom half is the RET or retainer ring.

Figure 23 - Fan HUB and RET Castings

Step 7: Determine the current blade pitch and the pin location for the new blades

Table 12 - Pin Location

| Type | Bushing Mount | Blade Pitch Angle | | | | | | | | | |
|------|---------------|-------------------|-----|-----|-----|-----|-----|-----|-----|-----|-----|
| | | 20° | 25° | 28° | 30° | 33° | 35° | 38° | 40° | 45° | 50° |
| 5Z | A | - | RET | - | RET | RET | RET | HUB | HUB | HUB | HUB |
| | B | - | HUB | - | HUB | HUB | HUB | RET | RET | RET | RET |

Table 13 - Pin Groove Location

| Type | Rot. | Blade Pitch Angle | | | | | | | | | |
|------|------|-------------------|-----|-----|-----|-----|-----|-----|-----|-----|-----|
| | | 20° | 25° | 28° | 30° | 33° | 35° | 38° | 40° | 45° | 50° |
| 5Z | R | - | 4 | - | 3 | 2 | 1 | 4 | 3 | 2 | 1 |
| | L | - | 1 | - | 2 | 3 | 4 | 1 | 2 | 3 | 4 |

Step 8: Replace fan blades in the new pin location and reassemble the fan

Replace the blades with the pin in the 1, 2, 3, or 4 groove position of either the HUB or RET. Assemble the fan making sure to place the blades in their previous blade sockets, to match up the previous orientation of HUB and RET and to replace any balancing weights in their previous locations. Tighten bolts in a cross pattern to 5-6 ft-lbs. of torque.

Power Return and Exhaust Axial Flow Fans (26 and 31-140 tons)

Blade Pitch Angle Setting Instructions

Step 1: Determine the new required pitch for the fan blades

Use the fan program in AAON ECat. Contact the AAON parts department to acquire the new pitch pins for the fan blades.

Step 2: Maintain the balance of fan

Mark the hub plate castings across a single joint, so the fan can be reassembled in the same orientation.

Mark the location of any balancing weight. Balancing weight will be on the outer bolt circle, in the form of washers, and/or longer bolts, or an additional balancing nut.

Number the blades and blade sockets, so that they can be replaced into their original positions.

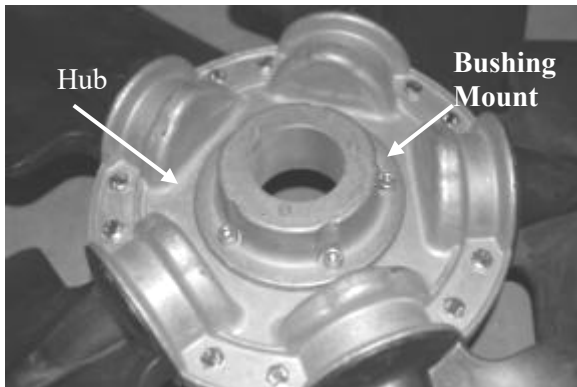

Figure 24- Assembled Fan

Step 3: Remove the mounting nuts and bolts and separate hub plate castings

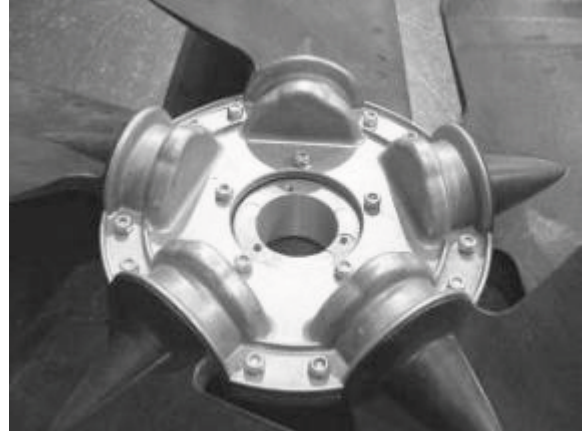

Figure 25 - Back of the Fan

Step 4: Remove the fan blades and replace the pitch pins

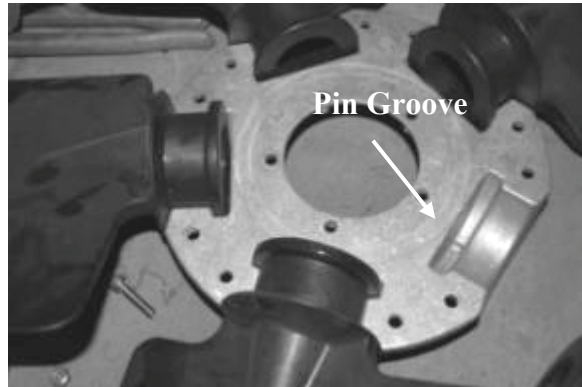

Figure 26 - Pin Groove Location

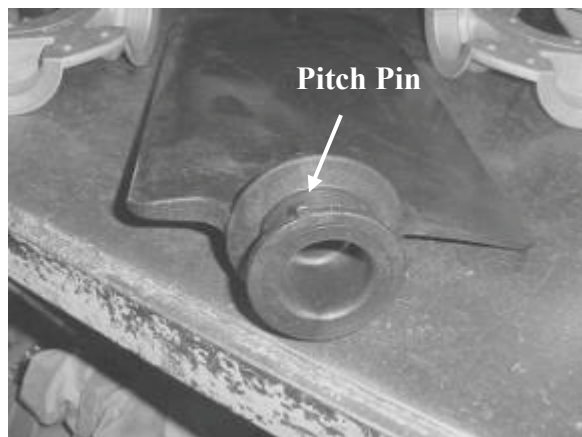

Figure 27 - Pitch Pin Location



Figure 28 - Example Pitch Pin

Step 5: Replace the fan blades with the pitch pin of the blade in the same groove and reassemble the fan.

Replace the blades and assemble the fan making sure to place the blades in their previous blade sockets, to match up the previous orientation of hub plate casings and to replace any balancing weights in their previous locations. Tighten bolts in a cross pattern to 9.1 Nm (6.7 ft-lbs.) of torque.

Step 6: Install the fan in the unit.

After placing the fan on the shaft, place the key in the shaft, make sure the screw on the bushing is aligned over the key and then tighten the screw to 12.2 Nm (9 ft-lbs) torque.

! CAUTION

A complete operating cycle must be observed to verify that all components are functioning properly before startup.

Adjusting Refrigerant Charge

Adjusting the charge of a system in the field must be based on determination of liquid sub-cooling and evaporator superheat. On a system with an expansion valve liquid sub-cooling is more representative of the charge than evaporator superheat but both measurements must be taken.

! CAUTION

The Clean Air Act of 1990 bans the intentional venting of refrigerant (CFC's and HCFC's) as of July 1, 1992. Approved methods of recovery, recycling or reclaiming must be followed. Fines and/or incarceration may be levied for non-compliance.

Before Charging

Unit being charged must be at or near full load conditions before adjusting the charge. Units equipped with hot gas reheat must be charged with the hot gas reheat valves closed while the unit is in cooling mode to get the proper charge. After charging, operate the unit in reheat (dehumidification) mode to check for correct operation.

Units equipped with heat pump options must be charged in heating mode to get the proper charge. After charging, operate the unit in cooling mode to check for correct charge. Charge may need to be adjusted for cooling mode. If adjustments are made in the cooling mode heating mode must be rerun to verify proper operation.

After adding or removing charge the system must be allowed to stabilize, typically 10-15 minutes, before making any other adjustments.

The type of unit and options determine the ranges for liquid sub-cooling and evaporator superheat. Refer to the table below when determining the proper sub-cooling.

Checking Liquid Sub-Cooling

Measure the temperature of the liquid line as it leaves the condenser coil.

Read the gauge pressure at the liquid line close to the point where the temperature was taken. You must use liquid line pressure as it

will vary from discharge pressure due to condenser coil pressure drop.

Convert the pressure obtained to a saturated temperature using the appropriate refrigerant temperature-pressure chart.

Subtract the measured liquid line temperature from the saturated temperature to determine the liquid sub-cooling.

Checking Evaporator Superheat

Measure the temperature of the suction line close to the compressor.

Read gauge pressure at the suction line close to the compressor.

Convert the pressure obtained to a saturated temperature using the appropriate refrigerant temperature-pressure chart.

Subtract the saturated temperature from the measured suction line temperature to determine the evaporator superheat.

Compare calculated superheat and subcool to the tables below for the appropriate coil and system type and options.

| |
|---|
| ! CAUTION |
| Expansion valve must be adjusted to approximately 4.4-8.3°C (8-15°F) of suction superheat. Failure to have sufficient superheat will damage the compressor and void the warranty. |

Table 14 - Acceptable Fin & Tube Air- Cooled Condenser Coil Refrigeration Circuit Values (Metric)

| Air-Cooled Cond./Air-Source Heat Pump In Cooling Mode | |
|--|-----------------------------|
| Sub-Cooling | 4.4-8.3°C / 1.1-2.2°C (HP)* |
| Sub-Cooling with Hot Gas Reheat | 4.4-8.3°C / 1.1-3.3°C (HP)* |
| Superheat | 4.4-8.3°C |

Table 15 -Acceptable Fin & Tube Air- Cooled Condenser Coil Refrigeration Circuit Values (Imperial)

| Air-Cooled Cond./Air-Source Heat Pump In Cooling Mode | |
|--|----------------------|
| Sub-Cooling | 8-15°F / 2-4°F (HP)* |
| Sub-Cooling with Hot Gas Reheat | 8-15°F / 2-6°F (HP)* |
| Superheat | 8-15°F |

Table 16 - Acceptable Water-Cooled Refrigeration Circuit Values (Metric)

| Water-Cooled Cond./Water Source Heat Pump In Cooling Mode | |
|--|-----------|
| Sub-Cooling | 2.2-4.4°C |
| Superheat | 4.4-8.3°C |

Table 17 - Acceptable Water-Cooled Refrigeration Circuit Values (Imperial)

| Water-Cooled Cond./Water Source Heat Pump In Cooling Mode | |
|--|--------|
| Sub-Cooling | 4-8°F |
| Superheat | 8-15°F |

Table 18 - Acceptable Microchannel Air-Cooled Condenser Coil Liquid Sub-Cooling Values (Metric)

| Ambient (°C) | Cooling Mode Liquid Sub-Cooling Values(°C) | | | | |
|-----------------|---|-----------|-----------|-----------|-----------|
| | Evaporator Coil Saturation Temperature (°C) | | | | |
| | 4.4 | 7.2 | 8.9 | 10.0 | 12.8 |
| 19.4 | 5.0 - 7.8 | 4.4 - 7.2 | 4.4 - 7.2 | 3.9 - 6.7 | 2.8 - 5.6 |
| 22.2 | 5.6 - 8.3 | 5.0 - 7.8 | 5.0 - 7.8 | 4.4 - 7.2 | 3.9 - 6.7 |
| 27.8 | 5.6 - 8.3 | 5.6 - 8.3 | 5.6 - 8.3 | 5.0 - 7.8 | 3.9 - 6.7 |
| 35.0 | 5.6 - 8.3 | 5.6 - 8.3 | 5.6 - 8.3 | 5.0 - 7.8 | 4.4 - 7.2 |
| 40.6 | 6.1 - 8.9 | 6.1 - 8.9 | 5.6 - 8.3 | 5.6 - 8.3 | 4.4 - 7.2 |
| 46.1 | 5.6 - 8.3 | 6.1 - 8.9 | 6.1 - 8.9 | 6.1 - 8.9 | 5.0 - 7.8 |

Table 19 - Acceptable Microchannel Air-Cooled Condenser Coil Liquid Sub-Cooling Values (Imperial)

| Ambient (°F) | Cooling Mode Liquid Sub-Cooling Values(°F) | | | | |
|-----------------|---|---------|---------|---------|--------|
| | Evaporator Coil Saturation Temperature (°F) | | | | |
| | 40 | 45 | 48 | 50 | 55 |
| 67 | 9 - 14 | 8 - 13 | 8 - 13 | 7 - 12 | 5 - 10 |
| 72 | 10 - 15 | 9 - 14 | 9 - 14 | 8 - 13 | 7 - 12 |
| 82 | 10 - 15 | 10 - 15 | 10 - 15 | 9 - 14 | 7 - 12 |
| 95 | 10 - 15 | 10 - 15 | 10 - 15 | 9 - 14 | 8 - 13 |
| 105 | 11 - 16 | 11 - 16 | 10 - 15 | 10 - 15 | 8 - 13 |
| 115 | 10 - 15 | 11 - 16 | 11 - 16 | 11 - 16 | 9 - 14 |

Notes:

1. Microchannel condenser coils are more sensitive to charge. The system must be running in cooling mode with compressor, supply airflow & condenser fan speed at full load. The sub-cooling value changes depending on the ambient temperature reading and the microchannel evaporator coil saturation temperature. To find the correct sub-cooling value, find the ambient temperature on the first column and follow that across to the SST (4.4-12.8°C [40-55°F]).
2. Superheat for Microchannel condenser coils must be between 4.4 and 8.3°C (8 - 15°F)

Adjusting Sub-cooling and Superheat
Temperatures

The system is overcharged if the sub-cooling temperature is too high and the evaporator is fully loaded (low loads on the evaporator result in increased sub-cooling) and the evaporator superheat is within the temperature range as shown in the table above (high superheat results in increased sub-cooling).

| |
|--|
|  CAUTION |
| DO NOT OVERCHARGE! |
| Refrigerant overcharging leads to excess refrigerant in the condenser coils resulting in elevated compressor discharge pressure. |

Correct an overcharged system by reducing the amount of refrigerant in the system to lower the sub-cooling.

The system is undercharged if the superheat is too high and the sub-cooling is too low.

Correct an undercharged system by adding refrigerant to the system to reduce superheat and raise sub-cooling.

If the sub-cooling is correct and the superheat is too high, the expansion valve may need adjustment to correct the superheat.

Freeze Stat Startup

Freeze Stat is an adjustable temperature sensor (-23.3°C to 21.1°C [-10 to 70°F]) mounted on the tubing of the first cooling circuit and wired to de-energize all cooling circuits if tubing temperature falls below setpoint. Option is used to prevent freezing of evaporator coil.

Recommended Setting: 0°C to 1.7°C (32° F to 35° F)

Table 20 - R-410A Refrigerant Temperature-Pressure Chart (Metric)

| °C | KPA | °C | KPA | °C | KPA | °C | KPA | °C | KPA |
|-------------|-------|-------------|--------|-------------|--------|-------------|--------|-------------|--------|
| -6.7 | 539.9 | 8.3 | 928.8 | 23.3 | 1473.5 | 38.3 | 2213.3 | 53.3 | 3193.8 |
| -6.1 | 551.6 | 8.9 | 946.0 | 23.9 | 1496.9 | 38.9 | 2245.0 | 53.9 | 3235.8 |
| -5.6 | 564.0 | 9.4 | 963.2 | 24.4 | 1521.0 | 39.4 | 2276.7 | 54.4 | 3277.9 |
| -5.0 | 576.4 | 10.0 | 980.5 | 25.0 | 1545.2 | 40.0 | 2309.1 | 55.0 | 3320.6 |
| -4.4 | 588.8 | 10.6 | 998.4 | 25.6 | 1570.0 | 40.6 | 2341.5 | 55.6 | 3363.4 |
| -3.9 | 601.2 | 11.1 | 1016.3 | 26.1 | 1594.8 | 41.1 | 2374.6 | 56.1 | 3406.8 |
| -3.3 | 614.3 | 11.7 | 1034.9 | 26.7 | 1619.6 | 41.7 | 2408.4 | 56.7 | 3450.9 |
| -2.8 | 627.4 | 12.2 | 1053.6 | 27.2 | 1645.1 | 42.2 | 2442.2 | 57.2 | 3495.1 |
| -2.2 | 640.5 | 12.8 | 1072.2 | 27.8 | 1670.7 | 42.8 | 2476.0 | 57.8 | 3539.9 |
| -1.7 | 654.3 | 13.3 | 1090.8 | 28.3 | 1696.2 | 43.3 | 2510.5 | 58.3 | 3585.4 |
| -1.1 | 667.4 | 13.9 | 1110.1 | 28.9 | 1722.4 | 43.9 | 2544.9 | 58.9 | 3630.9 |
| -0.6 | 681.2 | 14.4 | 1129.4 | 29.4 | 1749.3 | 44.4 | 2580.1 | 59.4 | 3677.1 |
| 0.0 | 695.7 | 15.0 | 1149.4 | 30.0 | 1775.5 | 45.0 | 2616.0 | 60.0 | 3724.0 |
| 0.6 | 709.5 | 15.6 | 1169.4 | 30.6 | 1802.4 | 45.6 | 2651.8 | 60.6 | 3771.6 |
| 1.1 | 724.0 | 16.1 | 1189.4 | 31.1 | 1829.9 | 46.1 | 2688.4 | 61.1 | 3819.1 |
| 1.7 | 738.5 | 16.7 | 1209.4 | 31.7 | 1857.5 | 46.7 | 2724.9 | 61.7 | 3867.4 |
| 2.2 | 752.9 | 17.2 | 1230.1 | 32.2 | 1885.8 | 47.2 | 2761.4 | 62.2 | 3915.7 |
| 2.8 | 768.1 | 17.8 | 1251.4 | 32.8 | 1914.1 | 47.8 | 2798.7 | 62.8 | 3965.3 |
| 3.3 | 783.3 | 18.3 | 1272.1 | 33.3 | 1942.3 | 48.3 | 2836.6 | 63.3 | 4015.0 |
| 3.9 | 798.4 | 18.9 | 1293.5 | 33.9 | 1971.3 | 48.9 | 2874.5 | 63.9 | 4065.3 |
| 4.4 | 814.3 | 19.4 | 1314.9 | 34.4 | 2000.2 | 49.4 | 2913.1 | 64.4 | 4115.6 |
| 5.0 | 829.5 | 20.0 | 1336.9 | 35.0 | 2029.9 | 50.0 | 2952.4 | 65.0 | 4167.3 |
| 5.6 | 846.0 | 20.6 | 1359.0 | 35.6 | 2059.5 | 50.6 | 2991.7 | 65.6 | 4219.1 |
| 6.1 | 861.9 | 21.1 | 1381.8 | 36.1 | 2089.2 | 51.1 | 3031.0 | | |
| 6.7 | 878.4 | 21.7 | 1403.8 | 36.7 | 2120.2 | 51.7 | 3071.0 | | |
| 7.2 | 895.0 | 22.2 | 1427.3 | 37.2 | 2150.6 | 52.2 | 3111.7 | | |
| 7.8 | 911.5 | 22.8 | 1450.0 | 37.8 | 2181.6 | 52.8 | 3153.1 | | |

Table 21 - R-410A Refrigerant Temperature-Pressure Chart (Imperial)

| °F | PSIG | °F | PSIG | °F | PSIG | °F | PSIG | °F | PSIG |
|-----------|-------|-----------|-------|------------|-------|------------|-------|------------|-------|
| 20 | 78.3 | 47 | 134.7 | 74 | 213.7 | 101 | 321.0 | 128 | 463.2 |
| 21 | 80.0 | 48 | 137.2 | 75 | 217.1 | 102 | 325.6 | 129 | 469.3 |
| 22 | 81.8 | 49 | 139.7 | 76 | 220.6 | 103 | 330.2 | 130 | 475.4 |
| 23 | 83.6 | 50 | 142.2 | 77 | 224.1 | 104 | 334.9 | 131 | 481.6 |
| 24 | 85.4 | 51 | 144.8 | 78 | 227.7 | 105 | 339.6 | 132 | 487.8 |
| 25 | 87.2 | 52 | 147.4 | 79 | 231.3 | 106 | 344.4 | 133 | 494.1 |
| 26 | 89.1 | 53 | 150.1 | 80 | 234.9 | 107 | 349.3 | 134 | 500.5 |
| 27 | 91.0 | 54 | 152.8 | 81 | 238.6 | 108 | 354.2 | 135 | 506.9 |
| 28 | 92.9 | 55 | 155.5 | 82 | 242.3 | 109 | 359.1 | 136 | 513.4 |
| 29 | 94.9 | 56 | 158.2 | 83 | 246.0 | 110 | 364.1 | 137 | 520.0 |
| 30 | 96.8 | 57 | 161.0 | 84 | 249.8 | 111 | 369.1 | 138 | 526.6 |
| 31 | 98.8 | 58 | 163.8 | 85 | 253.7 | 112 | 374.2 | 139 | 533.3 |
| 32 | 100.9 | 59 | 166.7 | 86 | 257.5 | 113 | 379.4 | 140 | 540.1 |
| 33 | 102.9 | 60 | 169.6 | 87 | 261.4 | 114 | 384.6 | 141 | 547.0 |
| 34 | 105.0 | 61 | 172.5 | 88 | 265.4 | 115 | 389.9 | 142 | 553.9 |
| 35 | 107.1 | 62 | 175.4 | 89 | 269.4 | 116 | 395.2 | 143 | 560.9 |
| 36 | 109.2 | 63 | 178.4 | 90 | 273.5 | 117 | 400.5 | 144 | 567.9 |
| 37 | 111.4 | 64 | 181.5 | 91 | 277.6 | 118 | 405.9 | 145 | 575.1 |
| 38 | 113.6 | 65 | 184.5 | 92 | 281.7 | 119 | 411.4 | 146 | 582.3 |
| 39 | 115.8 | 66 | 187.6 | 93 | 285.9 | 120 | 416.9 | 147 | 589.6 |
| 40 | 118.1 | 67 | 190.7 | 94 | 290.1 | 121 | 422.5 | 148 | 596.9 |
| 41 | 120.3 | 68 | 193.9 | 95 | 294.4 | 122 | 428.2 | 149 | 604.4 |
| 42 | 122.7 | 69 | 197.1 | 96 | 298.7 | 123 | 433.9 | 150 | 611.9 |
| 43 | 125.0 | 70 | 200.4 | 97 | 303.0 | 124 | 439.6 | | |
| 44 | 127.4 | 71 | 203.6 | 98 | 307.5 | 125 | 445.4 | | |
| 45 | 129.8 | 72 | 207.0 | 99 | 311.9 | 126 | 451.3 | | |
| 46 | 132.2 | 73 | 210.3 | 100 | 316.4 | 127 | 457.3 | | |

Condenser Fan Electronically Commutated Motor (ECM) Startup

The fan cycling option uses a fan cycle switch to switch between one of the discrete speed inputs (see Table 22) on the motor thus cycling between two preset speeds based upon discharge pressure of the unit. By connecting 24VAC to a single or combination of the yellow, white, or orange wires, the motor will run at the discrete speeds in Table 28.

With Customer Provided Unit Controls or AAON Condenser Head Pressure Module is used for variable speed control of the motor

to maintain a head pressure. The motor is factory wired to the Analog outputs of the AAON Condenser Head Pressure Module. See AAON literature for further information. (<https://www.aaon.com/Controls>)

Note

High voltage wires out of the motor:
Black & Brown - 1 Phase Line Voltage
Green - Ground

Low control voltage wires out of the motor:
Blue - Common
Yellow - Variable Speed Control

Table 22 - ECM Condenser Fan Cycling Options

| Color | Terminal | Customer Connection | Option 1 | Option 2 | Option 3 | Option 4 | Option 5 |
|----------------|------------|---------------------|-------------|-------------|-------------|-------------|-------------|
| Black | 0.50 BWS | L1 | 208-230 VAC | 208-230 VAC | 208-230 VAC | 208-230 VAC | 208-230 VAC |
| Brown | 0.50 BWS | L2 | 208-230 VAC | 208-230 VAC | 208-230 VAC | 208-230 VAC | 208-230 VAC |
| Green | #10 EYELET | Ground | GND | GND | GND | GND | GND |
| Blue | 0.50 BWS | Common | Common | 24 VAC | 24 VAC | 24 VAC | 24 VAC |
| Yellow | 0.50 BWS | Signal | Analog | | 24 VAC | | 24 VAC |
| White | 0.50 BWS | Signal | | | | 24 VAC | 24 VAC |
| Orange | 0.50 BWS | Signal | | 24 VAC | | 24 VAC | |
| RPM | | | 300-1100 | 300 | 500 | 850 | 1100 |
| Rotation | | | CCW | CCW | CCW | CCW | CCW |
| ECM Toolbox ID | | | Variable | Speed 4 | Speed 3 | Speed 2 | Speed 1 |
| 20% PWM RPM | | | 300 | | | | |
| 100% PWM RPM | | | 1100 | | | | |

VFD Controlled Condenser Fan Startup

With Customer Provided Unit Controls the VFD's are factory provided and factory programmed. VFD's receives input from pressure transducers on each refrigerant circuit and vary the fan speed based on the pressure inputs to maintain a discharge (head) pressure. Standard pressure setpoint is 2.34 Mpa 340 psi for standard air-cooled systems and 2.76 Mpa (400 psi) for

modulating hot gas reheat air-cooled systems.

With the AAON Condenser Head Pressure Module is used to maintain a discharge pressure. The VFD is factory wired to the outputs of the AAON Condenser Head Pressure Module. See AAON literature for additional information. (<https://www.aaon.com/Controls>).

Adjustable Fan Cycling Switch Procedure



Recommended Settings

The switch will come factory set to cut-in at 2.93 Mpa [425psi] (+/- 5psi) and a differential of 1.69 Mpa [155psi] (or open at 1.86 Mpa [270psi] (+/- 5psi)).

Note: 5 psi = 34.5 kpa

To adjust the fan cycle switch you will need a flathead screwdriver.



Settings for CUT IN and DIFFERENTIAL PRESSURE are indicated with two slider gauges.

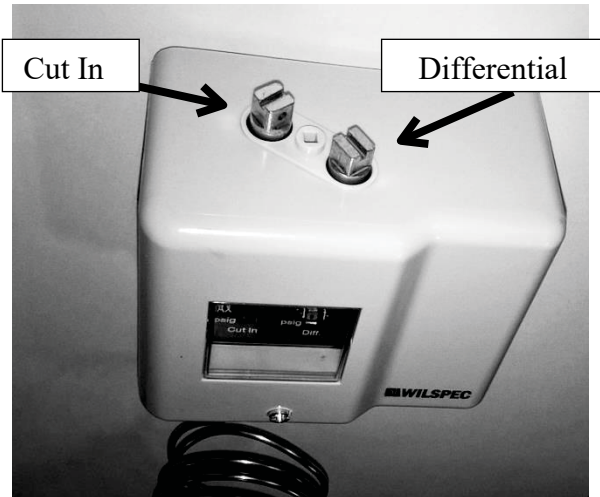

Each adjustment screw sits above the setting that it controls.

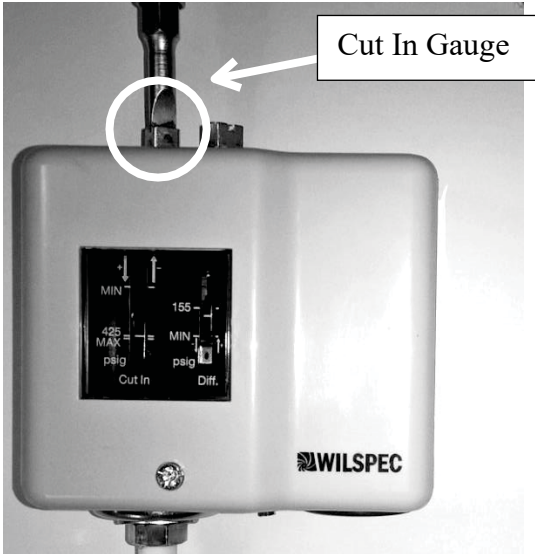

To lower the pressure set point for the **CUT IN** gauge, turn the adjustable screw clockwise.

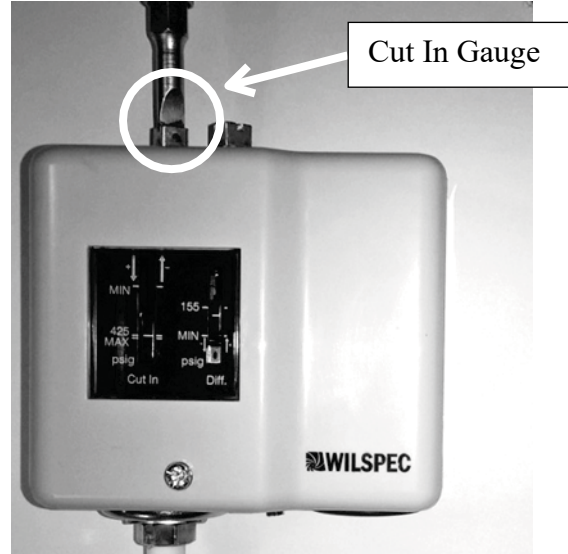

To raise the pressure set point for the **CUT IN** gauge, turn the adjustable screw counter clockwise.

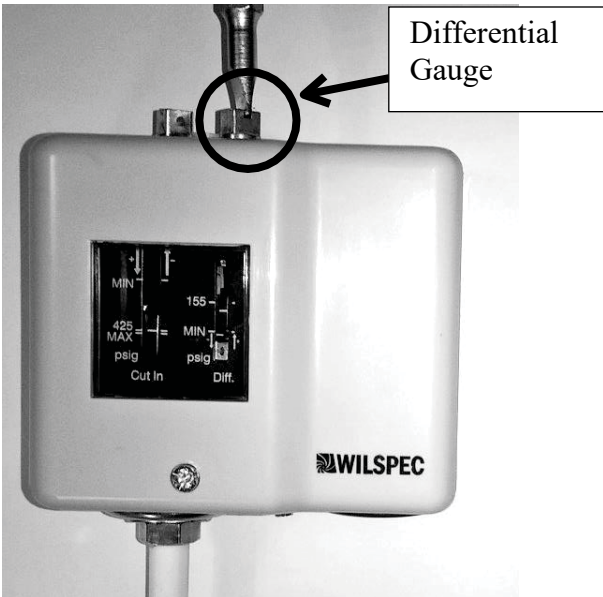

To raise the pressure set point for the **DIFFERENTIAL** Gauge, turn the adjustable screw clockwise.

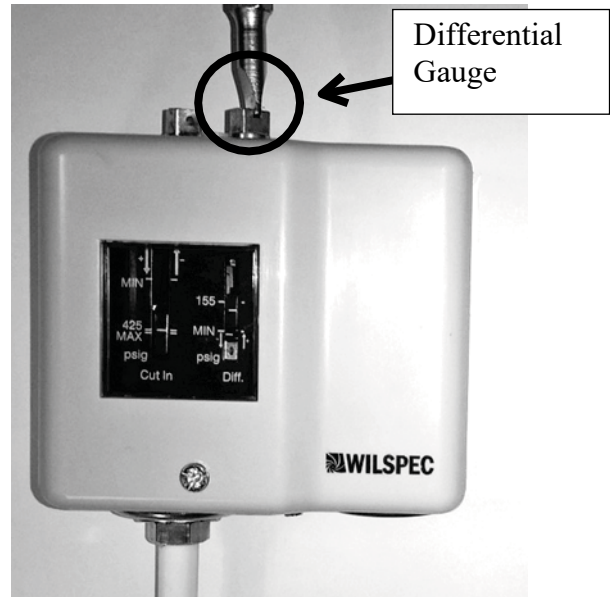

To lower the pressure set point for the **DIFFERENTIAL** Gauge, turn the adjustable screw counter clockwise.

NOTE: The pressure values on the gauge must be verified with gauges on the refrigerant line. The gauge scale is for illustration purposes only.

Operation

Unit operations must be controlled with thermostat, or unit controller, never at the main power supply, except for servicing, emergency, or complete shutdown of the unit.

Thermostat Operation

Heating

Thermostat system switch - "Heat"
Thermostat fan switch - "Auto" or "On"
Thermostat temperature set to desired point.

Cooling

Thermostat system switch - "Cool"
Thermostat fan switch - "Auto" or "On"
Thermostat temperature set to desired point.

Air Circulation

Thermostat system switch - "Off"
Thermostat fan switch - "Auto" or "On"
No change of the thermostat temperature.
With these settings, the supply blower will run continuously but the supply air will not be heated, cooled, or dehumidified.

System Off

Thermostat system switch - "Off"
Thermostat fan switch - "Auto"
No change of the thermostat temperature.
With these settings the system is shut down, with the exception of control system power.

Night and Weekend Unoccupied Operation

To reduce the operating time of the unit when the space is unoccupied, such as nights and weekends, it is recommended that the temperature setting be raised about -15°C (5°F) while unoccupied during the cooling season and lowered about -12.2°C (10°F) during the heating season.

Packaged DX Cooling Operation and Control

When a call for cooling (G and Y1, Y2, etc.) is made the supply blower motors and compressors will energize.

WARNING

COMPRESSOR CYCLING

3 MINUTE MINIMUM OFF TIME

To prevent motor overheating compressors must cycle off for a minimum of 3 minutes.

5 MINUTE MINIMUM ON TIME

To maintain the proper oil level compressors must cycle on for a minimum of 5 minutes.

The cycle rate must not exceed 7 starts per hour.

Note: When using field controls any variable capacity compressors must run at 100% for 1 minute when starting.

Gas Heater Operation

When heat (G and W1, W2, etc.) is called for the combustion motor starts and the ignition control is energized. The control sends 24 VAC to the main gas valve and high voltage to the igniter. If a burner flame has been detected within 10 seconds, the spark is extinguished and the flame continues. If a flame has not been detected after 10 seconds, the gas valve closes, the spark ceases and the induced draft blower continues to purge the heat exchanger. After 45 seconds of purge, the ignition system will attempt to light the burners again. Should no flame be detected after 3 tries, the ignition control will lock out the system. Power to the ignition control must be cycled to reset the heater control.

On a fault the gas train is shut down by a main limit located in the heat exchanger area or by an auxiliary limit mounted in the supply fan compartment.

Electric Heating Operation

When a call for heating (G and W1, W2, etc.) is made the supply blower motors and electric resistance heaters will energize. Heating is accomplished by passing electrical current through a specified amount of resistance heaters which will produce the required heat.

On a fault condition the main limit located in the supply air or the auxiliary limit located downstream the supply blower will remove power from all contactors.

Steam or Hot Water Preheating and Heating Operation

Valve control for steam and hot water heating coils are by others. Heating is accomplished by passing steam or hot water through the steam or hot water coil assembly.

Modulating Electric Preheat

Electric preheat is used to temper the incoming outside air to the unit based on an enable control signal and outside air conditions. Electric preheat has a maximum operation outside air temperature of 15.6 °C (60°F) and a maximum preheat discharge air temperature of 26.7°C (80°F).

Chilled Water or Non-Compressorized DX Cooling Operation

Controls for chilled water cooling coils and non-compressorized DX coil are by others.

Maintenance

(See back of the manual for maintenance log)

At least once each year, a trained, qualified service technician must check out the unit. Fans, evaporator coils, and filters must be inspected at least monthly.

Supply Fans

WARNING

Electric shock hazard. Shut off all electrical power to the unit to avoid shock hazard or injury from rotating parts.

CAUTION

Blower wheels and bands must be inspected for excessive dust build up periodically and cleaned if required. Excessive dust build up on blower wheels may cause an unbalanced state; leading to vibration and/or component failure. Damages due to excessive dust build up will not be covered under factory warranty.

Lubrication

All original fan motors and bearings are furnished with factory lubrication. Some applications will require that bearings be re-lubricated periodically. The schedule will depend on the operating duty, temperature variations or other severe atmospheric conditions.

Re-lubricate bearings when at normal operating temperatures, but not running. Rotate the fan shaft by hand and add only enough grease to purge the seals. **DO NOT OVERLUBRICATE.**

Recommended greases are:
SHELL OIL - DOLIUM R
CHEVRON OIL - SRI No. 2
TEXACO INC. - PREMIUM RB

Removal (6-25 and 30 tons)

Remove fan access panel. Panel is attached with eight 9.5mm (3/8") bolts.

Remove the wire connections from Auxiliary Limit Switch (if applicable) which is mounted in the brace at the fan opening.

Remove the brace located at the fan opening.

Remove the six bolts that connect the motor mount to the blower frame. Two bolts are on the angle on the back of the motor mount box, two are on the bottom inside the motor mount box and two are on the inside front of the motor mount box.



Figure 29 - 9-25 and 30 ton Supply Fan

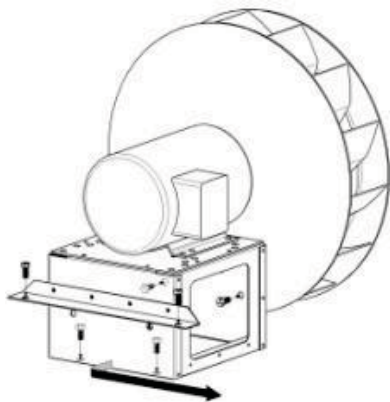

Figure 30 – Bolts which connect motor mount to fan

Slide the motor mount back away from the air inlet, so that the blower wheel is clear of the inlet. A screw driver or crowbar can be used to help accomplish this. Use the pry slots on the back side of the motor mount.

Pull the motor mount to the edge of the blower frame at the opening.

Remove the motor mount with the motor and blower wheel attached. Large motors will require more than one person.

Care must be taken not to damage the compressors or refrigerant lines when removing the motor and fan assembly.

Power Exhaust Motor and Belt Removal

1. Remove the four bolts holding the motor mount. There are rivet nuts on the backside.

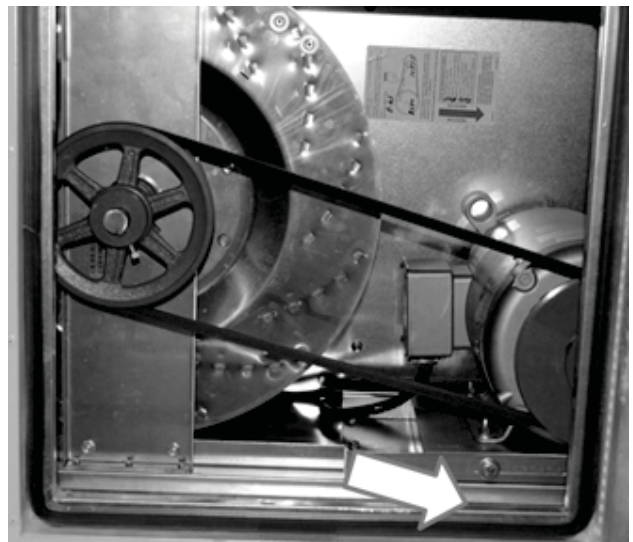

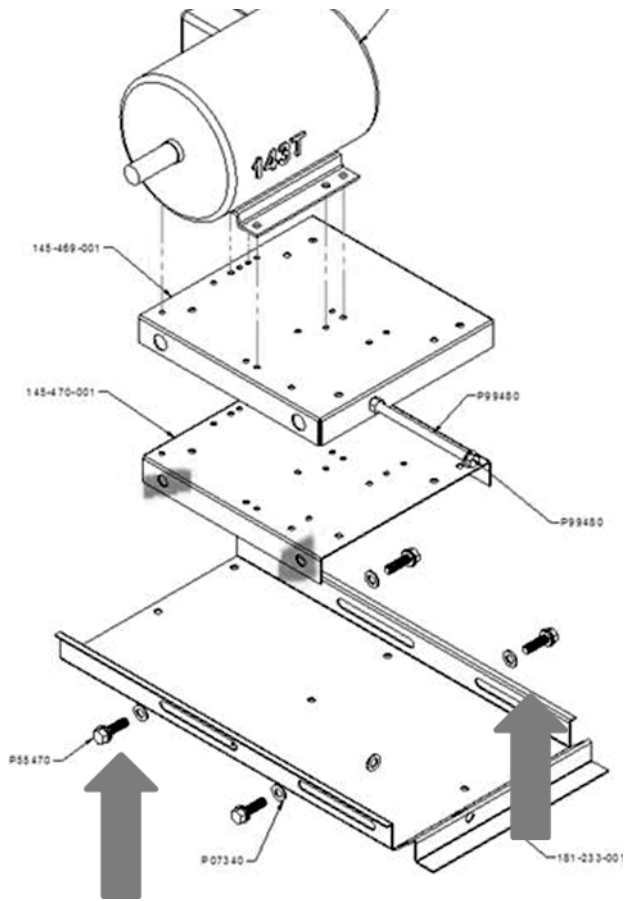

2. Remove the belt tensioner bolt completely, as indicated by the arrow below.

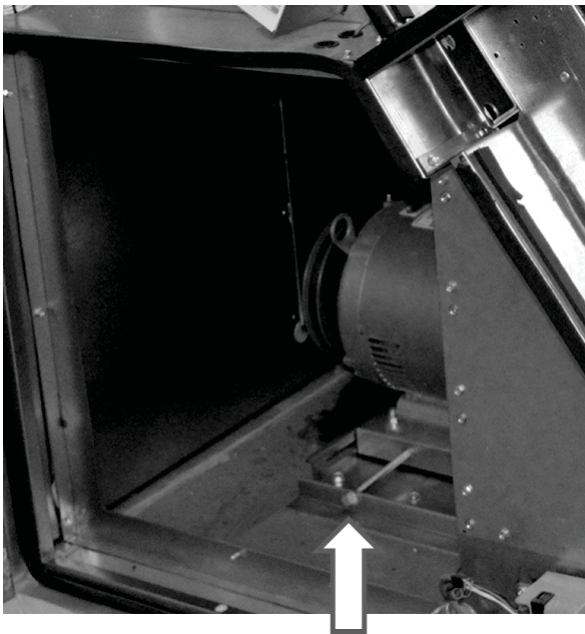

3. At this point the motor mount can be slid toward the wheel, and the belt can be removed.
4. Once the belt is removed the motor and mount can be lifted out. Make sure the wires to the motor are loose.

DX Cooling

Set unit controls to cooling mode of operation with supply fans on. Check the fan for correct operating direction, amperage and voltage. Check compressor operation, rotation, amperage and voltage to the unit nameplate (check the amperage on the load side of the compressor contactor).

Condensate Drain Pans

Drain pans will have moisture present and require periodic cleaning to prevent microbial growth. Cleaning of the drain pans will also prevent any possible plugging of the drain lines and overflow of the pan itself. Cleaning of the drain pans and inside of the unit must be done only by qualified service technician.

Brazed Plate Heat Exchanger Cleaning

Because of a normally high degree of turbulence in brazed plate heat exchangers, for many applications the heat exchanger channels are self cleaning. For applications that are not self cleaning (i.e. hard water at high temperatures, etc.) or applications where additional cleaning is desired, it is possible to clean the brazed plate heat exchanger by circulating a cleaning liquid.

Use a tank with weak acid, 5% phosphoric acid (H_3PO_4) or, if the exchanger is frequently cleaned, 5% oxalic acid ($H_2C_2O_4$). Pump the cleaning liquid through the exchanger. For optimum cleaning, the cleaning solution flow rate must be a minimum of 1.5 times the normal flow rate, preferably in a back-flush mode. After cleaning, the heat exchanger must be rinsed with clean water. A solution of 1-2% sodium hydroxide (NaOH) or sodium bicarbonate

(NaHCO) before the last rinse ensures that all acid is neutralized.

E-Coated Coil Cleaning

Documented routine cleaning of e-coated coils is required to maintain coating warranty coverage for fin and tube and microchannel coils. See the AAON E-Coated Coil Maintenance Record sheet.

WARNING

Electric shock hazard. Shut off all electrical power to the unit to avoid shock hazard or injury from rotating parts.

Surface loaded fibers or dirt must be removed prior to water rinse to prevent restriction of airflow. If unable to backwash the side of the coil opposite of the coils entering air side, then surface loaded fibers or dirt must be removed with a vacuum cleaner. If a vacuum cleaner is not available, a *soft non-metallic* bristle brush may be used. In either case, the tool must be applied in the direction of the fins. Coil surfaces can be easily damaged (fin edges bent over) if the tool is applied across the fins.

Use of a water stream, such as a garden hose, against a surface loaded coil will drive the fibers and dirt into the coil. This will make cleaning efforts more difficult. Surface loaded fibers must be completely removed prior to using low velocity clean water rinse.

A *monthly* clean water rinse is recommended for coils that are applied in coastal or industrial environments to help to remove chlorides, dirt, and debris. It is very important when rinsing, that water temperature is less than 54.4°C (130°F) and pressure is less than 689.5 kpa (100 psig) to avoid damaging the fin edges. An elevated water temperature (not to exceed 54.4°C

[130°F]) will reduce surface tension, increasing the ability to remove chlorides and dirt.

CAUTION

High velocity water from a pressure washer or compressed air must only be used at a very low pressure to prevent fin and/or coil damages. The force of the water or air jet may bend the fin edges and increase airside pressure drop. Reduced unit performance or nuisance unit shutdowns may occur.

Quarterly cleaning is essential to extend the life of an e-coated coil and is required to maintain coating warranty coverage.

Coil cleaning shall be part of the unit's regularly scheduled maintenance procedures. Failure to clean an e-coated coil will void the warranty and may result in reduced efficiency and durability.

CAUTION

Harsh chemicals, household bleach, or acid cleaners must not be used to clean outdoor or indoor e-coated coils. These cleaners can be very difficult to rinse out of the coil and can accelerate corrosion and attack the e-coating. If there is dirt below the surface of the coil, use the recommended coil cleaners.

For routine quarterly cleaning, first clean the coil with the below approved coil cleaner. After cleaning the coils with the approved cleaning agent, use the approved chloride remover to remove soluble salts and revitalize the unit.

Recommended Coil Cleaner

The following cleaning agent, when used in accordance with the manufacturer's directions on the container for proper mixing and cleaning, has been approved for use on e-coated coils to remove mold, mildew, dust, soot, greasy residue, lint, and other particulate:

Enviro-Coil Cleaner: AAON PN: V82540

GulfClean™ Coil Cleaner; AAON PN: G074480

Recommended Chloride Remover

GulfClean Salt Reducer™; AAON PN: G074490

GulfClean Salt Reducer™ is used to remove soluble salts from the e-coated coil, follow the manufacturer's instructions. This product is not intended for use as a degreaser. Any grease or oil film must first be removed with GulfClean™ Coil Cleaner.

Remove Barrier - First ensure the power to the unit is off and locked out. Clean the area around the unit if needed to ensure leaves, grass or loose debris will not be blown into the coil. Soluble salts adhere themselves to the substrate. For the effective use of this product, the product must be able to come in contact with the salts. These salts may be beneath any soils, grease or dirt; therefore, these barriers must be removed prior to application of this product. As in all surface preparation, the best work yields the best results.

Application - Apply GulfClean™ Coil Cleaner directly onto the substrate. Sufficient product must be applied uniformly across the substrate to thoroughly wet out surface, with no areas missed. This may be accomplished by use of a pump-up sprayer or conventional spray gun. Apply the cleaner to unit interior air exiting side coil

surfaces first. Work in sections/panels moving side to side and from top to bottom. Allow the cleaning solution to soak for 5 to 10 minutes. Then move on to the exterior using the same method.

Rinse - Using pressurized potable water such as a garden hose, (< 689.5 kpa [100 psi]), rinse the coils and continue to always work in sections/panels.

Continue until all coil areas on the inside of the unit have been rinsed. ***Note: Coils must always be cleaned / back flushed, opposite of airflow to prevent impacting the dirt into the coil.***

Repeat these steps with GulfClean™ Salt Reducer. When finished replace all panels and tops that were removed.

Microchannel Coil Cleaning

Cleaning microchannel coils is necessary in all locations. In some locations it may be necessary to clean the coils more or less often than recommended. Condenser coil must be cleaned at a minimum of once a year. In locations where there is commonly debris or a condition that causes dirt/grease build up it may be necessary to clean the coils more often. Proper procedure must be followed at every cleaning interval. Using improper cleaning technique or incorrect chemicals will result in coil damage, system performance fall off, and potentially leaks requiring coil replacement.



Documented routine cleaning of microchannel coils with factory provided e-coating is required to maintain coating warranty coverage. Use the E-Coated Coil Cleaning section for details on cleaning e-coated coils.

Field applied coil coatings are not recommended with microchannel coils.

Allowed Chemical Cleaners and Procedures

AAON recommends certain chemicals that can be used to remove buildup of grime and debris on the surface of microchannel coils. These chemicals have been tested for performance and safety and are the only chemicals that AAON will warrant as correct for cleaning microchannel coils.

There are two procedures that are outlined below that will clean the coils effectively without damage to the coils. Use of any other procedure or chemical may void the warranty to the unit where the coil is installed. **With all procedures make sure the unit is off before starting.**

| |
|--|
|  WARNING  |
| Electric shock hazard. Shut off all electrical power to the unit to avoid shock hazard or injury from rotating parts. |

The water pressure used to clean must not exceed 689.5 kpa (100 psi), from no closer than 15.25 centimeters (6 inches) from the coils, and with the water aimed perpendicular to the coils.

#1 Simple Green

Simple Green is available from AAON Parts and Supply (Part# T10701) and is biodegradable with a neutral 6.5 pH. A 4 to 1 solution is recommended. Use the following procedure.

1. Rinse the coil completely with water. Use a hard spray but be careful not to bend or damage the fins. A spray that is too hard will bend the fins. Spray from the fan side of the coil.
2. With a pump sprayer filled with a mix of 4 parts water to one part Simple Green spray the air inlet face of the coil. Be sure to cover all areas of the face of the coil.

3. Allow the coil to soak for 10-15 minutes.
4. Rinse the coil with water as in step one.
5. Repeat as necessary.

#2 Water Flush

This procedure can be used when the only material to cause the coil to need cleaning is debris from plant material that has impinged the coil face.

1. Rinse the coil completely with water. Use a hard spray but be careful not to bend or damage the fins. A spray that is too hard will bend the fins. Spray from the fan side of the coil.
2. Spray and rinse the coil from the face.

| |
|---|
|  CAUTION |
| Use pressurized clean water, with pressure not to exceed 689.5 kpa (100 psi). Nozzle must be 15.25 centimeters (6") and perpendicular to the coil face. Failure to do so could result in coil damage. |

Application Examples

The two procedures can be used to clean microchannel coils. They will fit with the application depending on the area. In some areas where the spring/summer has a large cottonwood bloom #2 might work fine if the unit is installed on an office building and no other environmental factors apply.

Generally the best and broadest based procedure is #1. The grease cutting effect of the Simple Green is good for restaurant applications.

Other Coil Cleaners

There are many cleaners on the market for condenser coils. Before using any cleaner that is not covered in this section you must get written approval from the AAON warranty and service department. Use of

unapproved chemicals will void the warranty.

AAON testing has determined that unless a chemical has a neutral pH (7) it must not be used.

Beware of any product that claims to be a foaming cleaner. The foam that is generated is caused by a chemical reaction to the aluminum fin material on tube and fin coils and with the fin, tube, and coating material on microchannel coils.

Microchannel coils are robust in many ways, but like any component they must be treated correctly. This includes cleaning the coils correctly to give optimal performance over many years.

Roofing

The cleaning procedures outlined here use relatively non-caustic ingredients. When working with a rooftop unit care must be taken to make sure the chemicals will not adversely affect the roof coating. Checking with the roofing supplier/manufacturer is the best way to proceed. If the roofing supplier/manufacturer is not available testing of the chemicals on the roof coating is recommended.

Commercial roofing material manufacturers using PVC and EPDM have been contacted and indicate that there should be no problem with any of the procedures outlined above.

Options

(See back of the manual for maintenance log)

Heating Coils

One or two row hot water and steam heating and preheating coils can be factory installed. All valve controls for heating operation are field supplied and field installed. Hot water and steam coil connections are spun copper tube.

Water coils must not be subjected to entering air temperatures below 3.3°C (38°F) to prevent coil freeze-up. If air temperature across the coil is going to be below this value, use a glycol solution to match the coldest air expected.

WARNING

Piping, pressure limiting devices, backflow preventers and all other safety requirements shall be in accordance with national and local codes.

CAUTION

The unit shall have proper sealing of the water piping entries into the unit. Failure to seal the entries may result in damage to the unit and property.

Table 23 - Steam Coil Connection Sizes

| Model (RN-) | Steam Coil Connection Size [mm (in)] | Steam Preheat [mm (in)] | Coil Connection Quantity* |
|------------------------------|--------------------------------------|-------------------------|---------------------------|
| 006, 007, 008, 010 | 51 (2) MPT | 51 (2) MPT | 1/1 |
| 009, 011, 013, 015 | 51 (2) MPT | 51 (2) MPT | 1/1 |
| 014, 016, 018, 020, 025, 030 | 51 (2) MPT | 51 (2) MPT | 1/1 |

* In/Out Connections

Table 24 - Hot Water Coil Connection Sizes

| Model (RN-) | Hot Water Coil Connection Size [mm (in)] | Hot Water Preheat [mm (in)] | Coil Connection Quantity* |
|------------------------------|--|-----------------------------|---------------------------|
| 006, 007, 008, 010 | 35 (1 3/8) | 35 (1 3/8) | 1/1 |
| 009, 011, 013, 015 | 35 (1 3/8) | 35 (1 3/8) | 1/1 |
| 014, 016, 018, 020, 025, 030 | 35 (1 3/8) | 35 (1 3/8) | 1/1 |

* In/Out Connections

Chilled Water Coil

Four or six row chilled water cooling coils can be factory installed. All valve controls for cooling operation are field supplied and field installed. Chilled water coil connections are spun copper tube.

Table 25 - Chilled Water Coil Connection Sizes

| Model (RN-) | Chilled Water Coil Connection Size [mm (in)] | Coil Connection Quantity* |
|--|--|---------------------------|
| 006, 007, 008, 009, 010, 011, 013, 015 | 41 (1 5/8) | 1/1 |
| 016, 018, 020, 025, 030 | 54 (2 1/8) | 1/1 |

* In/Out Connections

Table 26 - Min and Max Water Pressures and Temps

| | Chilled Water | Hot Water |
|---------------------|--------------------|----------------|
| Min. Entering Air | 15.6°C (60°F) | 4.4 °C (40°F) |
| Max Entering Air | 37.8°C (100°F) | 26.7°C (80°F) |
| Min. Entering Water | 1.7°C (35°F) | 60°C (140°F) |
| Max Entering Water | 18.3°C (65°F) | 93.3°C (200°F) |
| Min. Water Pressure | 0 kpa (15 psig) | |
| Max Water Pressure | 2068kpa (300 psig) | |

Packaged Direct Expansion (DX) Units

 **WARNING**

COMPRESSOR CYCLING

3 MINUTE MINIMUM OFF TIME
To prevent motor overheating compressors must cycle off for a minimum of 3 minutes.

5 MINUTE MINIMUM ON TIME
To maintain the proper oil level compressors must cycle on for a minimum of 5 minutes.

The cycle rate must not exceed 7 starts per hour.

 **CAUTION**

CRANKCASE HEATER OPERATION

Some units are equipped with compressor crankcase heaters, which must be energized at least 24 hours prior to cooling operation, to clear any liquid refrigerant from the compressors.

All DX refrigeration systems are factory assembled, leak tested, charged with refrigerant, and run tested.

All refrigerant systems include an evaporator, condenser, liquid line filter driers, expansion valves and scroll compressors.

Never cut off the main power supply to the unit, except for servicing, emergency, or complete shutdown of the unit. When power is cut off from the unit crankcase heaters cannot prevent refrigerant migration into the compressors. This means the compressor will cool down and liquid refrigerant may accumulate in the compressor. The compressor is designed to pump refrigerant gas and damage may occur when power is restored.

If power to the unit must be off for more than an hour, turn the thermostat system switch to "OFF", or turn the unit off at the control panel, and leave the unit off until the main power switch has been turned on again for at least 24 hours for units with compressor crankcase heaters. This will give the crankcase heater time to clear any liquid accumulation out of the compressor before it is started.

Always control the unit from the thermostat, or control panel, never at the main power supply, except for servicing, emergency or complete shutdown of the unit.

During the cooling season, if the air flow is reduced due to dirty air filters or any other reason, the cooling coils can get too cold which will cause excessive liquid to return to the compressor. As the liquid concentration builds up, oil is washed out of the compressor, leaving it starved for lubrication.

The compressor life will be seriously shorted by reduced lubrication and the pumping of excessive amounts of liquid oil and refrigerant.

Note: Low Ambient Operation

Air-cooled DX units without a low ambient option, such as condenser fan cycling or the -17.8°C (0°F) low ambient option, will not operate in the cooling mode of operation properly when the outdoor temperature is below 12.8°C (55°F). Low ambient and/or economizer options are recommended if cooling operation below 12.8°C (55°F) is expected.

⚠ CAUTION

Polyolester (POE) and Polyvinylether (PVE) oils are two types of lubricants used in hydrofluorocarbon (HFC) refrigeration systems. Refer to the compressor label for the proper compressor lubricant type.

Note: Multiple Units with Multiple Thermostats

When several heating and cooling units are used to condition a space all unit thermostat switches must be set in either heating mode, cooling mode or off. Do not leave part of the

units switched to the opposite mode. Cooling only units must be switched off at the thermostat during the heating season.

Variable Capacity Compressor Controller

Units with variable capacity scroll compressors may include the following compressor controller. The following is an explanation of the terminals and troubleshooting alert flash codes of the controller. For more information on the compressor controller, see Emerson Climate Bulletin AE8-1328.

Note: When using field controls any variable capacity compressors must run at 100% for 1 minute when starting.

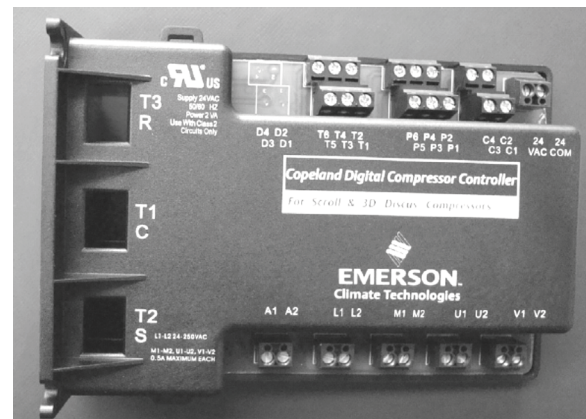

Figure 31 - Variable Capacity Compressor Controller

⚠ WARNING

To avoid damaging the Compressor Controller do not connect wires to terminals C3, C4, T3, T4, T5, or T6.

Low Voltage Terminals

- 24COM Module Common
- 24VAC Module Power
- C1 & C2 Demand Input – & +
- P1 Pressure Common
- P2 Pressure Input

P3 Pressure Power 5VDC
P4 Pressure Shield
P5 & P6 Pressure Output – & +
T1 & T2 Discharge Temperature Sensor

pattern according to the capacity demand signal of the system. The following table shows the linear relationship between the demand signal and compressor capacity modulation. The compressor controller protects the compressor against high discharge temperature. Refer to Appendix B for the relationship between thermistor temperature readings and resistance values.

High Voltage Terminals

A1 & A2 Alarm Relay Out
M1 & M2 Contactor
L1 Control Voltage N
L2 Control Voltage L
U1 & U2 Digital Unloader Solenoid
V1 & V2 Vapor Injection Solenoid

The compressor controller modulates the compressor unloader solenoid in an on/off

Table 27 - Demand Signal vs. Compressor Capacity Modulation

| Demand Signal (VDC) | Loaded % | Unloaded % | Time Loaded | Time Unloaded | % Compressor Capacity |
|---------------------|----------|------------|-------------|---------------|-----------------------|
| 1.00 | Off | Off | Off | Off | 0% |
| 1.44 | 10% | 90% | 1.5 sec | 13.5 sec | 10% |
| 3.00 | 50% | 50% | 7.5 sec | 7.5 sec | 50% |
| 4.20 | 80% | 20% | 12 sec | 3 sec | 80% |
| 5.00 | 100% | 0% | 15 sec | 0 sec | 100% |

| LED Descriptions | Troubleshooting ALERT Flash Codes |
|---|---|
| Green LED - 24VAC Power Yellow LED - Unloader Solenoid On Red LED - ALERT Flash Code | Code 1 Reserved for future use |
| <ul style="list-style-type: none"> Flashing Green LED indicates anti-short cycle timer active All LEDs flashing at same rate indicates 24VAC supply too low for operation All LEDs solid at same time indicates controller failure Reset ALERT code or lockout by removing 24VAC supply to module All ALERTs close alarm relay contacts All ALERTs deenergize contactor and solenoids except Code 6 Compressor always unloads for 0.1 second at startup Compressor only starts when Demand signal input is above 1.45 VDC and no ALERTs are present | Code 2 High Discharge Temperature Discharge thermistor above trip set point or thermistor short circuited. Resets after 30 minutes and motor cools down. If 5 events occur within 4 hours, the compressor is locked out. |
| | Code 3 Compressor Protector Trip No compressor current is detected when compressor should be running. Resets when compressor current is detected. |
| | Code 4 Locked Rotor Locked rotor condition is detected. Compressor is locked out. |
| | Code 5 Demand Signal Loss Demand input signal is below 0.5VDC. Resets after demand input signal rises above 1.0VDC. |
| | Code 6 Discharge Thermistor Fault Thermistor is not connected. Reset by reconnecting thermistor. |
| | Code 7 Reserved for future use |
| | Code 8 Compressor Contactor Fault Compressor current is detected when compressor should be off. Resets when current is no longer detected. |
| | Code 9 Low 24VAC Supply Supply voltage to module has dropped below 18.5VAC. Resets after voltage rise above 19.5VAC. |

Figure 32 - Compressor Controller Flash Code Details

Evaporator Coil (6-25 and 30 ton)

WARNING

Electric shock hazard. Shut off all electrical power to the unit to avoid shock hazard or injury from rotating parts.

Removal

Evacuate refrigerant from the systems.

Remove the expansion valve bulbs from the suction lines. Disconnect the suction and liquid line copper connections to the evaporator coil.

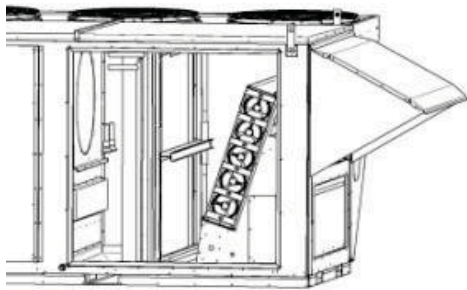

Figure 33 - Evaporator Coil Access

Remove the screws attaching the filter rack to the evaporator coil blank-off panels at the door opening and along the top of the coil.

Remove the screws attaching the filter rack to the back wall. Angle filter rack away from coil so it fits through the door opening. It may be necessary to remove economizer damper assembly.

Remove screws attaching access side, back, and top blank-off panels to the evaporator coil and the unit.

Angle the coil so that it fits through the door opening.

Remove the evaporator coil.

Reinstallation

Install the coil in the unit drain pan. There should be about a 0.7 centimeter (1/4") gap between the upstream side of the coil and the back of the drain pan.

Secure the coil to the back wall of the unit with the blank-off panel. Attach the top and access side blank-off panels to the coil.

Attach the filter rack to the back, top, and access side coil blank-off panels upstream of the coil. Reinstall economizer damper assembly if necessary.

Connect the suction and liquid copper connections to the evaporator coil. Reinstall the expansion valve bulbs on the suction lines.

Evacuate the refrigerant systems. Weigh in the nameplate refrigerant charge.

See *Adjusting Refrigerant Charge* section to check for proper sub-cooling and superheat of the refrigerant systems.

Condenser Fans (6-25 and 30 ton)

Condenser fans and motors can be removed and reinstalled as individual assemblies.

WARNING

Electric shock hazard. Shut off all electrical power to the unit to avoid shock hazard or injury from rotating parts.

! WARNING

Improper installation, adjustment, alteration, service, or maintenance can cause property damage, personal injury, or loss of life. Startup and service must be performed by a Factory Trained Service Technician.

Removal

Take off the fan grill by removing the screws that attach it to the orifice.

The condenser fan motor wires can then be accessed and disconnected.

Remove the screws that attach the orifice to the condenser assembly. The screws are located on the top of the orifice around the perimeter, and in some cases, through the side of the condenser assembly into the orifice.

With the wires disconnected and the screws removed, the fan, motor and orifice assembly can be lifted off the unit.



Figure 34 - Removal of a Condenser Fan Assembly

Reinstallation

Set the condenser fan, motor and orifice assembly back into the condenser assembly with the motor wires on the side closest to the control panel.

Attach the orifice to the condenser assembly using all of the points where screws were removed.

Reconnect the fan motor wires.

Attach the fan grill at all of the points where screws were removed.

Suction Filter (55, 65 and 75-140 ton)

In an effort to help protect the compressors from contaminants during testing and startup, AAON is now factory installing pleated replaceable core suction line filters on the RNE Series products (55, 65, and 75-140 tons)



Figure 35 - RPE-48-BD filter element

One month after startup, remove the RPE-48-BD filter element for the lowest possible pressure drop. Removing the suction line filter will improve the efficiency and capacity of the unit. AAON installs isolation ball valves on both sides of the suction line filter

so the complete system will not have to be reclaimed/evacuated.

Suction Filter Removal Instructions

1. Shut down operation of the unit
2. Close both shut-off valves to isolate the suction filter
3. Reclaim the refrigerant from the suction filter section



4. Remove the bolts from the suction filter end plate

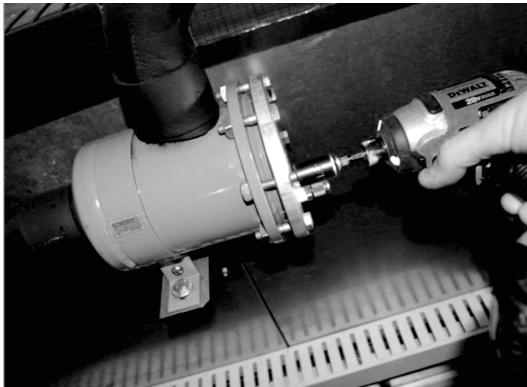

5. Remove the pleated filter assembly

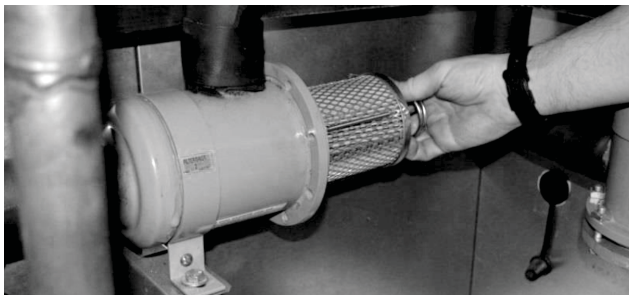

6. Replace the suction filter end plate and bolts
7. Evacuate the suction filter assembly to 300 microns
8. Open both shut-off valves

Refrigerant-to-Water Heat Exchanger

Condenser water pump, condenser water piping, cooling tower or geothermal loop, pressure gauges, strainers, piping insulation and all components of the waterside piping must be field installed.

Water-Source Heat Pump Applications

Water-source heat pump units using 100% outside air must have electric preheat if the application has a potential for operation with air entering the indoor coil below 6.1°C (43°F) with a water loop temperature of 21.1°C (70°F).

! CAUTION

WATER-SOURCE HEAT PUMP APPLICATIONS

Water-source heat pump units using 100% outside air must have electric preheat if the application has a potential for heat pump heating operation with air entering the indoor coil below 6.1°C (43°F) with an entering water loop temperature of 21.1°C (70°F).

Open Loop Applications

This product contains one or more refrigerant-to-water heat exchangers made of 316 Stainless Steel. 316 Stainless Steel is subject to severe corrosion and failure when exposed to chlorides.

! WARNING

OPEN LOOP APPLICATIONS

Failure of the condenser as a result of chemical corrosion is excluded from coverage under AAON Inc. warranties and the heat exchanger manufacturer's warranties.

Do not allow water containing any form of chlorides to enter this heat exchanger.

Common forms of chlorides include:

1. Sea water mist entering an open cooling tower system.
2. Contaminated makeup water containing salt water.
3. Disinfecting the water loop with solutions containing sodium hypochlorite.

Chlorides will result in a premature failure of the condenser.

Failure of the condenser as a result of chemical corrosion is excluded from coverage under AAON warranties and the heat exchanger manufacturer warranties.

Failure of the condenser will allow water to enter the refrigerant circuit and will cause extensive damage to the refrigerant circuit components. Any damage to the equipment as a result of condenser failure from chemical corrosion due to the fluid in the condenser is excluded from coverage under AAON warranties and the heat exchanger manufacturer warranties.

| |
|--|
|  WARNING |
| OPEN LOOP APPLICATIONS |
| Coated brazed plated refrigerant-to-water heat exchangers are recommended with all open loop applications. Failure to use a coated heat exchanger may result in premature failure of your system and possible voiding of the warranty. |

| |
|---|
|  CAUTION |
| Cleaning the cooling tower or condenser water loop with harsh chemicals such as hydrochloric acid (muriatic acid), chlorine or other chlorides, can damage the refrigerant-to-water heat exchanger. Care must be taken to avoid allowing chemicals to enter the refrigerant-to-water heat exchanger. See Appendix A - Heat Exchanger Corrosion Resistance for more information. |

Freezing Water in the Heat Exchanger

This product contains one or more refrigerant-to-water heat exchangers. A refrigerant-to-water heat exchanger contains refrigerant in one passage and water in another passage. Water is subject to freezing at 0°C (32°F). When water freezes in a heat exchanger significant forces are exerted on the components of the heat exchanger where the water is confined.

| |
|--|
|  WARNING |
| WATER FREEZING |
| Failure of the condenser due to freezing will allow water to enter the refrigerant circuit and will cause extensive damage to the refrigerant circuit components. Any damage to the equipment as a result of water freezing in the condenser is excluded from coverage under AAON warranties and the heat exchanger manufacturer warranties. |

Failure of the condenser due to freezing will allow water to enter the refrigerant circuit and will cause extensive damage to the

refrigerant circuit components. Any damage to the equipment as a result of water freezing in the condenser is excluded from coverage under AAON warranties and the heat exchanger manufacturer warranties.

Unit is capable of operating with Entering Water Temperatures (EWT) as low as 13.9°C (57°F), during the cooling mode, without the need for head pressure control. If the EWT is expected to be lower than 13.9°C (57°F) or a more stable operation is desired, a factory provided head pressure control water valve option is available.

Glycol solution must be used if ambient temperatures are expected to fall below freezing or if the loop entering water temperature to the unit is below 10°C (50°F) while operating in the heating mode (heat pump units only). Adding glycol to condenser water causes an increase in pressure drop and also results in a decrease in unit performance. A minimum concentration of 20% glycol solution is recommended.

Table 28 - Glycol Freezing Points

| % Glycol | Ethylene Glycol [°C (°F)] | Propylene Glycol [°C (°F)] |
|----------|------------------------------|-------------------------------|
| 20 | -7.8 (18) | -7.2 (19) |
| 30 | -13.9 (7) | -12.8 (9) |
| 40 | -21.7 (-7) | -21.1 (-6) |
| 50 | -33.3 (-28) | -32.8 (-27) |

Water loop piping runs through unheated areas or outside the building must be insulated.

Water Piping

Verify that a water flow switch is installed between the condenser water supply and return connections. This sensor provides a signal to the unit controller that water flow is present in the refrigerant-to-water heat

exchanger and the unit can operate without damaging unit components.

! WARNING

WATER PRESSURE

Prior to connection of condensing water supply, verify water pressure is less than maximum pressure shown on unit nameplate. To prevent injury or death due to instantaneous release of high pressure water, relief valves must be field supplied on water piping. Supply water connection may require a backflow preventer to prevent supply makeup water from backing up into the public water system.

Table 29 - Standard Brazed Plate Heat Exchanger Water Connections

| Model (RN-) | Supply and Return Connection Size [mm (in)] |
|---|--|
| 006, 007 | 25 (1) NPT |
| 008, 010, 009, 011, 013, 015, 016, 018, 020 | 38 (1 1/2) NPT |
| 025, 030 | 51 (2) NPT |

Only use approved water pipe material. Avoid using galvanized material for water lines/fittings as the material is corrosive and may cause fouling of the water system. Condenser water pump must be field sized and installed between the cooling tower/geothermal loop and self-contained unit. Size the system in accordance with the ASHRAE Handbook. Use engineering guidelines to maintain equal distances for supply and return piping and limit bend

radiuses to maintain balance in the system. Balancing valves, permanent thermometers and gauges may be required.

Before connection to the unit the condenser water system must be flushed to remove foreign material that could cause condenser fouling. A screen strainer with a minimum of 20 Mesh is provided ahead of the condenser inlet to prevent condenser fouling and internal tube damage.

Mineral content of the condenser water must be controlled. All makeup water has minerals in it and as the water is evaporated in the cooling tower, these minerals remain. As the mineral content of the water increases, the conductivity of the water increases.

CAUTION

WATER PIPING

Follow national and local codes when installing water piping. Connections to the unit must incorporate vibration eliminators to reduce noise and vibration and shutoff valves to facilitate servicing. Supply and return water piping must be at least as large as the unit connections and larger depending on length of runs, rise and bends.

Field provided and installed water treatment program must be compatible with stainless steel, copper, aluminum, ABS plastic, and PVC. Batch feed processes must never be used as concentrated chemicals can cause corrosion. Never use hydrochloric acid (muriatic acid) or chlorine as it will corrode stainless steel.

CAUTION

PVC (Polyvinyl Chloride) and CPVC (Chlorinated Polyvinyl Chloride) are vulnerable to attack by certain chemicals. Polyolester (POE) oils used with R-410A and other refrigerants, even in trace amounts, in a PVC or CPVC piping system will result in stress cracking of the piping and fittings and complete piping system failure.

CAUTION

Each heat exchanger may be equipped with a refrigerant pressure relief device to relieve pressure should excessive condensing pressures (4.65 Mpa [>675 psig]) occur. Codes may require a qualified technician to connect and route relief piping outdoors. The relief valve has a 1.6 cm (5/8") male flare outlet connection.

NOTE: Ball valves must be installed in the condenser water supply and return lines for unit isolation and water flow balancing. All manual flow valves must be of the ball valve design. Globe or gate valves must not be used due to high pressure drops and poor throttling characteristics.

Pressure and temperature ports are recommended in condenser water supply and return lines for system balancing. These openings must be 5 to 10 pipe diameters from the unit water connections. To allow for mixing and temperature stabilization, wells in the water piping must extend at least $\frac{1}{2}$ pipe diameter into the pipe.

! CAUTION

A qualified technician is responsible for properly sizing and installing water system components. Improper fluid flow due to valves, piping, or improper pump operation may result in unacceptable unit operation and void warranty.

Piping systems must not exceed 3 m/sec (10 ft/sec) fluid velocity to ensure tube wall integrity and reduce noise.

Energy Recovery Units

Some RN units have been equipped with an energy recovery wheel. AAON provides options for either an aluminum energy recovery wheel or a polymer energy recovery wheel. Follow the instructions for the specific type of energy recovery wheel in your installed equipment.

! WARNING

Improper installation, adjustment, alteration, service or maintenance can cause property damage, personal injury or loss of life. Startup and service must be performed by a Factory Trained Service Technician.

Initial Mechanical Check and Setup

Outdoor units equipped with outside air intake will have an outside air hood. The outside air hood must be opened prior to unit operation.

Outdoor air intake adjustments must be made according to building ventilation, or local code requirements.

After the unit installation is complete, open the cassette access door and determine that the energy wheel rotates freely when turned by hand. Apply power and observe that the wheel rotates. If the wheel does not rotate when power is applied, it may be necessary to readjust the “diameter air seals”.

Airflow Balancing and Checking

High performance systems commonly have complex air distribution and fan systems. Unqualified personnel must not attempt to adjust fan operation, or air circulation, as all systems have unique operations characteristics. Professional air balance specialists must be employed to establish actual operating conditions, and to configure the air delivery system for optimal performance.

Controls

A variety of controls and electrical accessories may be provided with the equipment. Identify the controls on each unit by consulting appropriate submittal, or order documents, and operate according to the control manufacturer’s instructions. If you cannot locate installation, operation, or maintenance information for the specific controls, then contact your sales representative, or the control manufacturer for assistance.

! WARNING

Do not alter factory wiring. Deviation from the supplied wiring diagram will void all warranties, and may result in equipment damage or personal injury. Contact the factory with wiring discrepancies.

Aluminum Energy Recovery Wheel

This section is provided to assure the energy recovery feature will be properly setup to perform in accordance with the job specifications for your particular application.

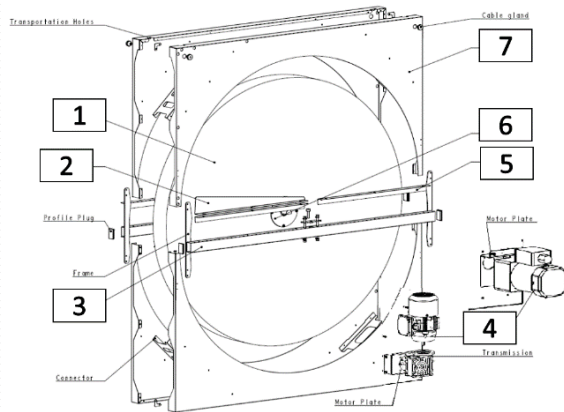

Figure 36 - Aluminum Energy Recovery Wheel

1. Monolith energy recovery wheel
2. Purge Sector
3. Profile
4. Motor
5. Brush Plate
6. Rotor Hub
7. Casing

Aluminum Wheel Check Purge Location

The purge sector is an optional element so it may not be installed on some units. Ensure the purge sector is mounted in the correct location. Purge sector must be located on the fresh supply air side. Based on the airflow and the wheel rotation in the following illustrations, notice the correct locations for the purge sector.

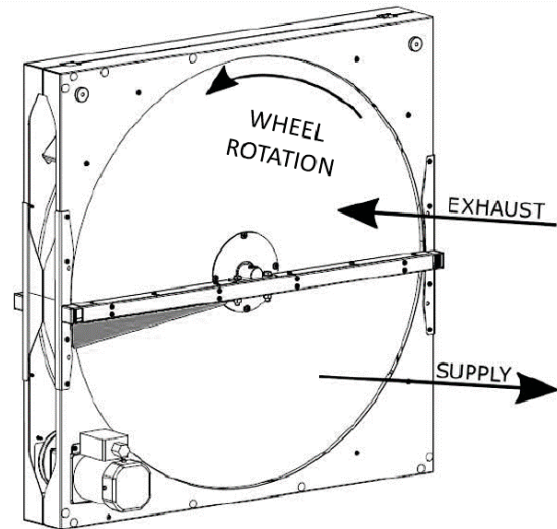
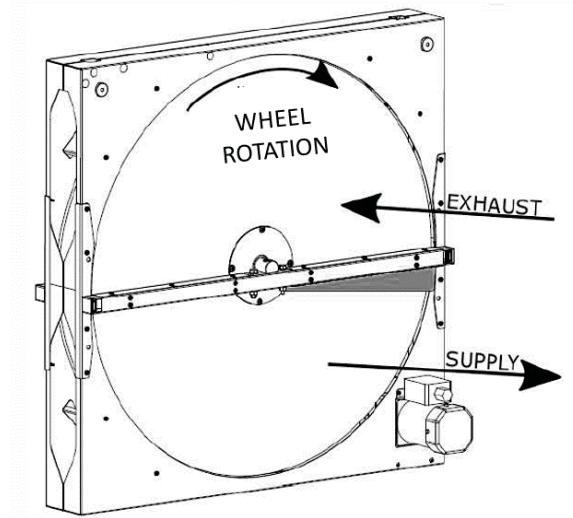

Figure 37 - Aluminum ERW Purge Sector Location

Aluminum Wheel Air Seals

Both non-contact sealing on wheel peripheries and brush sealing middle beam are maintenance-free but their condition must be checked every year. During the inspection, check their tightness and overall visual condition. Non-contact seals must not be flipped, rolled or pierced at any place

If seals are damaged, please contact our technical support immediately. A damaged

seal may cause efficiency deterioration, mixing of an air flows and unwanted leakages in the system, especially in environments with hygienic requirements.

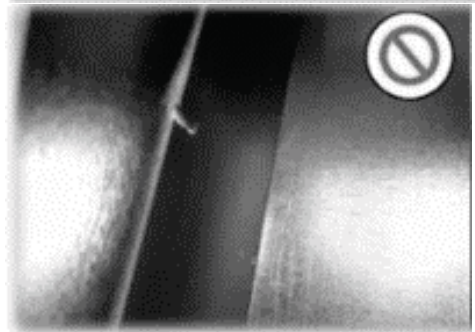
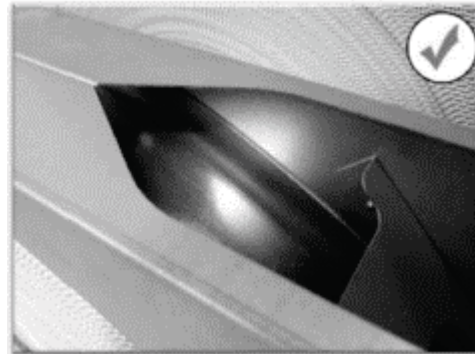
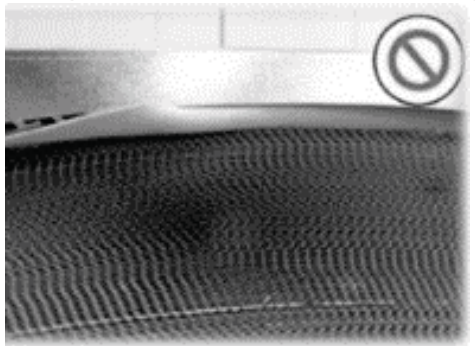
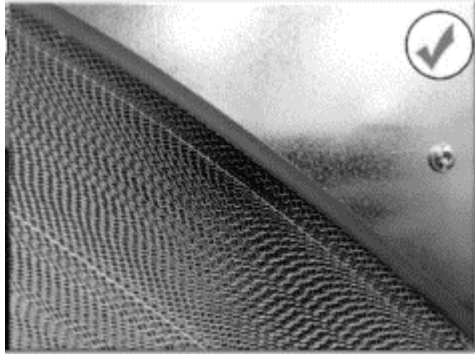

Aluminum Wheel Brush Plate

Brushes are located on both upper sides of the profiles. Inspect their condition and whether they adhere to the surface of the wheel matrix. Over time, the brushes may lose their cleaning properties and it will be necessary to replace them or simply change their position on the profile. In order to adjust their position unscrew them and place properly.

Aluminum Wheel Purge Sector

Purge sectors are maintenance-free but their condition, rigidness and cleanliness must be checked every year. Pay attention to the distance of the sector against the recovery wheel matrix. Use compressed air to clean, if required.

Aluminum Wheel Drive Components

Drive belt requires periodic inspections. Due to material property, belt may stretch, therefore it may require user to increase the tension, upon inspection.

Belt tension must be checked after the first 24 hours of operation and at least once per year.

If segmented drive belt becomes too loose it is necessary to pull out few segmentmodules (Figure 50) of the belt and shorten the overall length to desired amount in order to achieve optimal tension.

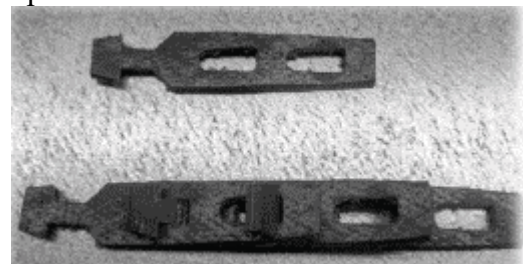

Correct tension should prevent ability to insert anything underneath the belt on the entire length between the belt and the wheel. Belt must not slip.

Annually inspect the visual condition of the belt all along the wheel. Be sure that belt does

not show signs of mechanical damage. Check the convergence on the wheel pulley. The belt must pass freely without encountering any obstacles inside the housing. Due to the segmented design of the belt, replacing individual segments is enough to restore functionality. Please follow the instructions below, presenting proper way of replacing segments or increasing belt tension.

1. Unclip the belt using pliers. Grab the protruding tongue of the segment to remove and twist it to release the segment from the chain. Disconnect the belt in that place.

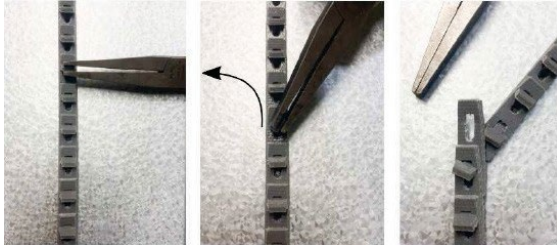

2. Remove the necessary amount of segments to increase the belt tension.
3. Connect the shortened belt ends by inserting the protruding tongue through the hole of the other half of the belt.
4. Grab the second tongue and similarly insert it through the second hole – this time use the pliers to drag the segment tongue easier and twist it back to the starting position.
5. Your belt is now shortened and the tension of the belt is increased.

Polymer Energy Recovery Wheel

This section is provided to assure the polymer energy recovery feature will be properly setup to perform in accordance with the job specifications for your particular application.

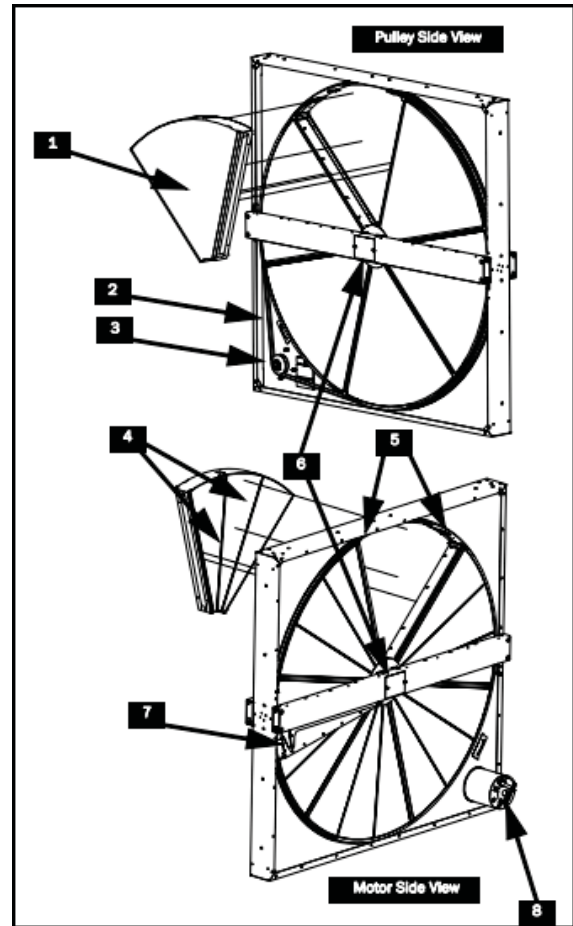

Figure 38 - Polymer Energy Recovery Wheel

1. Removable Segment
2. Permanent Tension Belt
3. Pulley
4. Embedded Segment Stiffeners
5. Segment Retaining Latches
6. Bearing Beam and Bearing Access Cover Plate (Diameter Seals are behind Bearing Beam on both sides)
7. Adjustable Purge
8. Motor

The Energy Recovery Cassette consists of a frame wheel, wheel drive system, and energy transfer segments. Segments are removable for cleaning or replacement. The segments rotate through counter flowing exhaust and outdoor air supply streams where they transfer heat and/or water vapor from the

warm, moist air stream to the cooler and/or drier air stream.

The initial setup and servicing of the energy recovery wheel is very important to maintain proper operation efficiency and building occupant comfort.

Normal maintenance requires periodic inspection of filters, the cassette wheel, drive belts, air seals, wheel drive motor, and its electrical connections.

Wiring diagrams are provided with each motor. When wired according to wiring diagram, motor rotates clockwise when viewed from the shaft/pulley side.

By carefully reviewing the information within this section and following the instructions, the risk of improper operation and/or component damage will be minimized.

It is important that periodic maintenance be performed to help assure trouble free operation.

Polymer Wheel Set Purge Angle

When installed, the purge angle is factory set to 5 degrees. If a different angle is required, complete the following steps to adjust the purge:

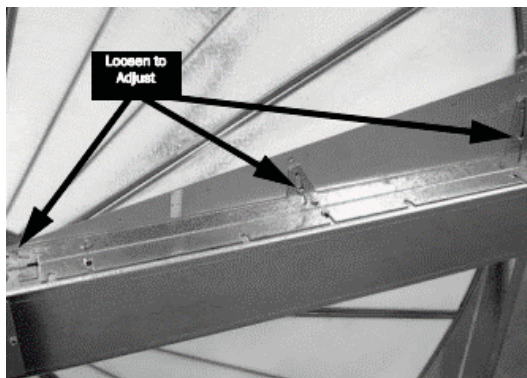

1. Loosen the three purge adjusting screws.

2. Adjust purge sector to the specified angle.

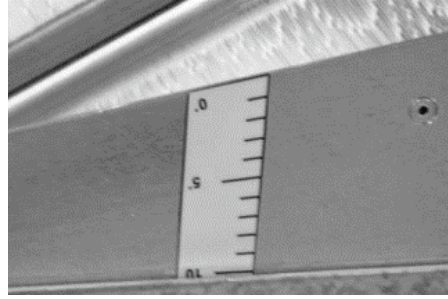

3. Tighten the purge adjusting screws.
4. Turn the wheel by hand clockwise (when viewed from pulley side) to check for interference.

Polymer Wheel Check Purge Seal

If a purge is installed, check for a slight interference fit between the seal and the face of the wheel by sliding a piece of paper ("feeler gauge") between the seal and the media a multiple locations along the purge seal as you rotate the wheel slowly by hand (clockwise when viewed from the pulley side). Verify that the media slightly grabs the paper during rotation.

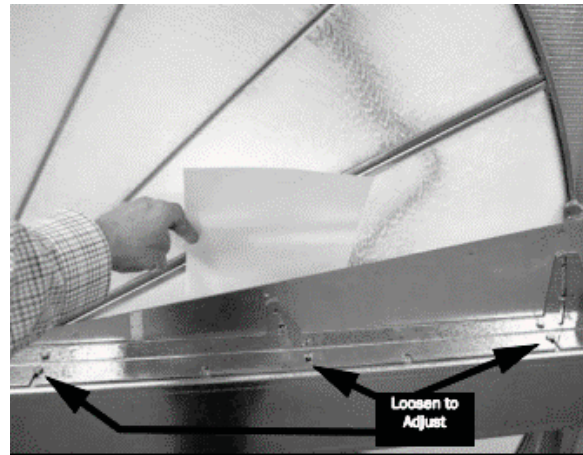

If it is necessary to adjust a purge seal to the face of the wheel, loosen the two or three screws along the bearing beam and adjust to the proper distance from the media surface. Tighten the screws and retest the seal.

Polymer Wheel Air Seal Adjustments

Pile type air seals across both sides of the energy wheel diameter are factory adjusted to provide close clearance between the air seal and wheel. Racking of the unit or cassette during installation, and/or mounting of the unit on a non-level support or in other than the factory orientation can change seal clearances. Tight seals will prevent rotation.

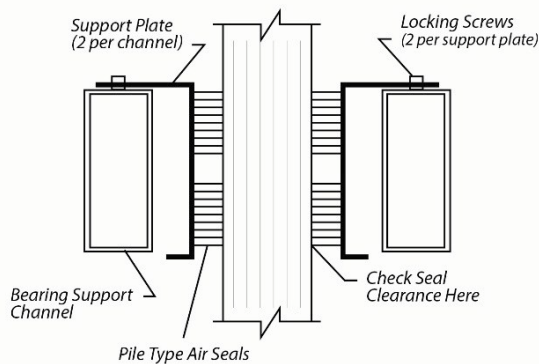

Cross Section of Air Seal Structure

Polymer Wheel to Air Seal Clearance

To check wheel to seal clearance; first disconnect power to the unit, in some units the energy recovery wheel assembly can be pulled out from the cabinet to view the air seals. On larger units, the energy recovery wheel may be accessible inside the walk-in cabinet.

A business card or two pieces of paper can be used as a feeler gauge, (typically each .1 mm [.004"] thick) by placing it between the face of the wheel and pile seal.

Using the paper, determine if a loose slip fit exist between the pile seal and wheel when the wheel is rotated by hand.

To adjust air seal clearance, loosen all seal plate retaining screws holding the separate seal retaining plates to the bearing support channels and slide the seals plates away from the wheel. Using the paper feeler gauge, readjust and retighten one seal plate at a time

to provide slip fit clearance when the wheel is rotated by hand.

Confirm that the wheel rotates freely. Apply power to the unit and confirm rotation. Visually inspect the belt and ensure the belt is tracking near the center of the rim. Verify the wheel speed is approximately 45-50 RPM. Confirm there is no excessive noise such as scraping, brushing, or banging.

Polymer Wheel Installation

Energy recovery cassettes are incorporated within the design of packaged units, packaged air handlers and energy recovery ventilators. In each case, it is recommended that the following considerations be addressed:

Polymer Wheel Accessibility

The cassette and all its operative parts; i.e.: motor, belt, pulley, bearings, seals and energy transfer segments must be accessible for service and maintenance. This design requires that adequate clearance be provided outside the enclosure. Where cassettes are permanently installed in a cabinet, access to both sides of the cassette must be provided.

Polymer Wheel Orientation & Support

The Energy Recovery Cassette may be mounted in any orientation. However, Care must be taken to make certain that the cassette frame remains flat and the bearing beams are not racked.

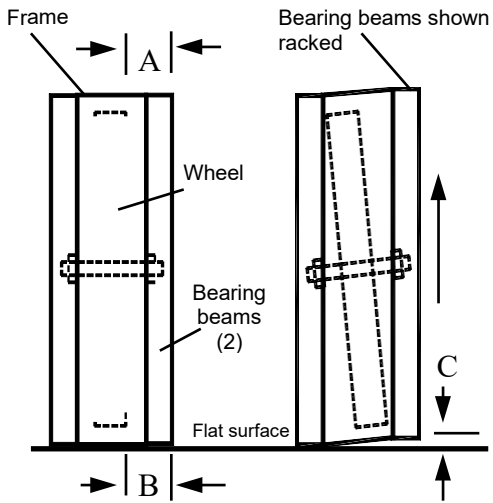

Avoid Racking of Cassette Frame

To verify, make certain that the distance between wheel rim and bearing beam is the same at each end of the bearing beam, to within .64 centimeters (1/4 of an inch) (dimension A & B). This amount of racking can be compensated for by adjusting the diameter seals.

If greater than .64 centimeters (1/4 of an inch) (dimension C), racking must be corrected to ensure that drive belt will not disengage from wheel.

Polymer Wheel Startup Procedure



CAUTION

Keep hands away from rotating wheel!
Contact with rotating wheel can cause physical injury.

1. By hand, turn wheel clockwise (as viewed from the pulley side), to verify wheel turns freely through 360° rotation.
2. Before applying power to drive motor, confirm wheel segments are fully engaged in wheel frame and segment retainers are completely fastened. (See Segment Installation Diagram).

3. With hands and objects away from moving parts, activate unit and confirm wheel rotation. Wheel rotates clockwise (as viewed from the pulley side).
4. If wheel has difficulty starting, turn power off and inspect for excessive interference between the wheel surface and each of the four (4) diameter seals. To correct, loosen diameter seal adjusting screws and back adjustable diameter seals away from surface of wheel, apply power to confirm wheel is free to rotate, then re-adjust and tighten hub and diameter seals, as shown in hub seal adjustment diagram.
5. Start and stop wheel several times to confirm seal adjustment and to confirm belt is tracking properly on wheel rim (approximately .64 centimeters [1/4 of an inch] from outer edge of rim).

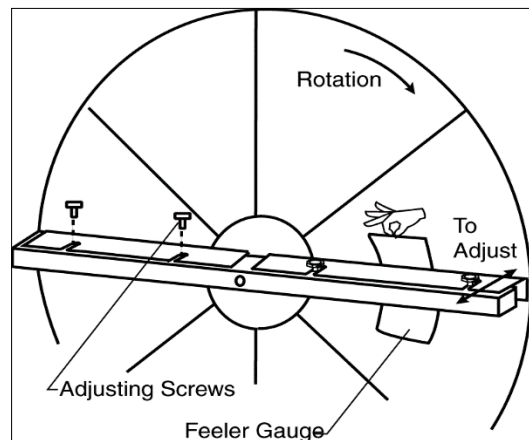

Diameter Seal Adjustment

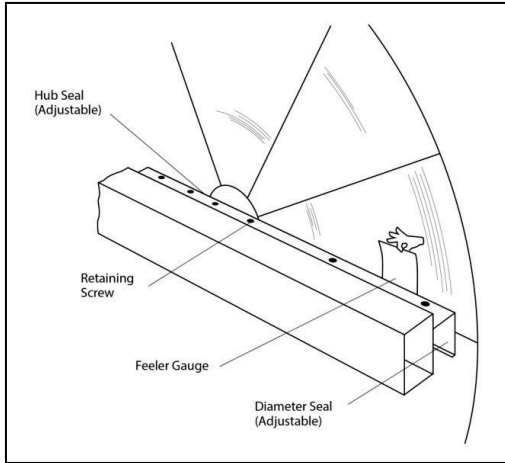

Hub Seal Adjustment

Polymer Wheel Routine Maintenance and Handling

Handle cassettes with care. Lift all cassettes by the bearing support beam. Holes are provided on both sides of the bearing support beams to facilitate rigging as shown in the following illustration.

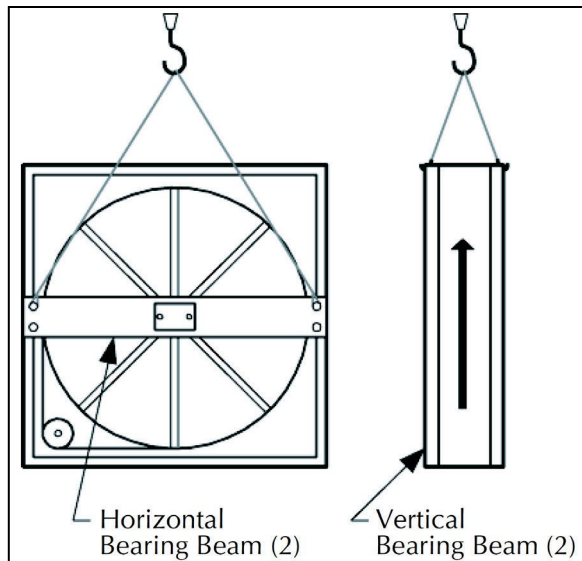

Lifting Hole Locations

Routine maintenance of the Energy Recovery Cassettes includes periodic cleaning of the Energy Recovery Wheel as well as inspection of the Air Seals and Wheel Drive Components as follows:

Polymer Wheel Air Seals

Four adjustable diameter seals are provided on each cassette to minimize transfer of air between the counter flowing airstreams.

To adjust diameter seals, loosen diameter seal adjusting screws and back seals away from wheel surface. Rotate wheel clockwise until two opposing spokes are hidden behind the bearing support beam. Using a folded piece of paper as a feeler gauge, position paper between the wheel surface and diameter seals.

Adjust seals towards wheel surface until a slight friction on the feeler gauge (paper) is detected when gauge is moved along the length of the spoke. Retighten adjusting screws and recheck clearance with “feeler” gauge.

Polymer Wheel Drive Components

The wheel drive motor bearings are pre-lubricated and no further lubrication is necessary.

The wheel drive pulley is secured to the drive motor shaft by a combination of either a key or D slot and set screw.

The set screw is secured with removable loctite to prevent loosening. Annually confirm set screw is secure. The wheel drive belt is a urethane stretch belt designed to provide constant tension through the life of the belt. No adjustment is required. Inspect the drive belt annually for proper tracking and tension. A properly tensioned belt will turn the wheel immediately after power is applied with no visible slippage during start-up.

Polymer Wheel Service

CAUTION

Disconnect electrical power before servicing energy recovery cassette. Always keep hands away from bearing support beam when installing or removing segments. Failure to do so could result in severe injury to fingers or hand.

Polymer Wheel Segment Installation & Replacement

An uneven number of segments in the wheel will cause the wheel to accelerate in rotation. Minimize wheel imbalance and unwanted rotation during service by installing or removing opposing segments for even weight distribution. Failure to maintain control of the wheel rotation while removing or installing all segments could cause severe injury to fingers or hands. Always close and secure segment retaining latches before rotating wheel.

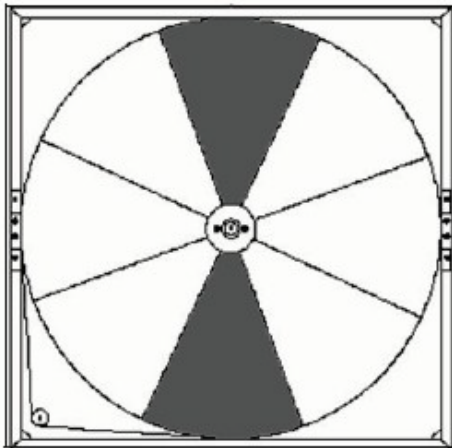
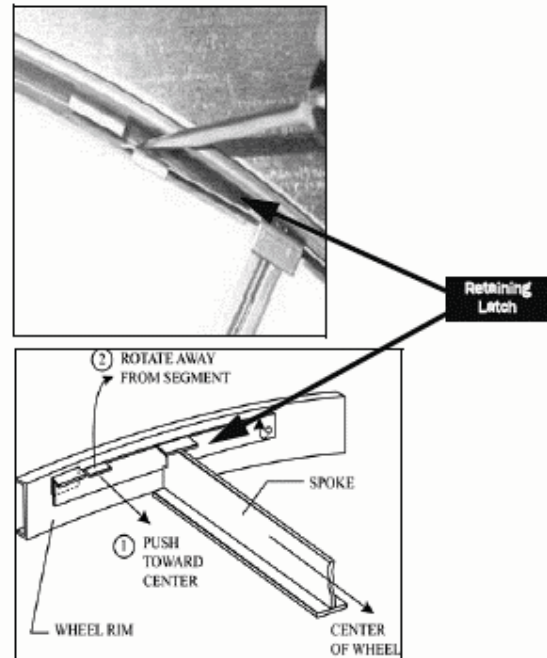

Figure 39 - Wheel Segment Removal Pattern

Wheel segments are secured to the wheel frame by a Segment Retainer which pivots on the wheel rim and is held in place by a Segment Retaining Latches.



Segment Retainer

To install wheel segments follow the steps below. Reverse procedure for segment removal.

Disconnect power from the wheel.
Gain access to the wheel and slide wheel frame out of cabinet.

1. Unlock two segment retainers (one on each side of the selected segment opening).
2. With the embedded stiffener facing the motor side, insert the nose of the segment between the hub plates.

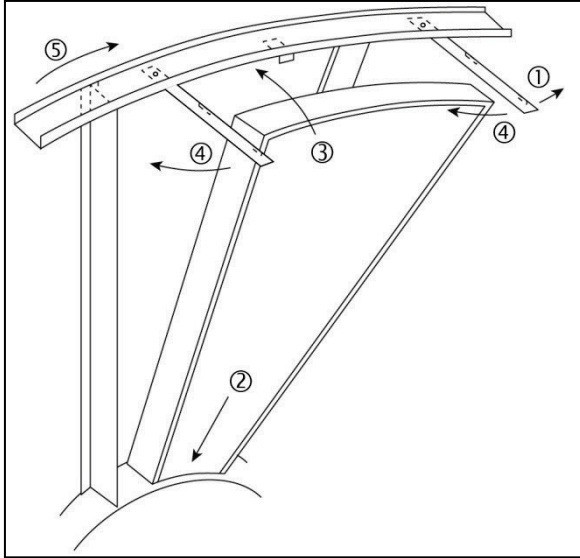

Segment Installation

3. Holding segment by the two outer corners, press the segment towards the center of the wheel and inwards against the spoke flanges. If hand pressure does not fully seat the segment, insert the flat tip of a screw driver between the wheel rim and outer corners of the segment and apply downward force while guiding the segment into place.
4. Close and latch each Segment Retainer under Segment Retaining Catch.
5. Slowly rotate the wheel 180°. Install the second segment opposite the first for counterbalance. Rotate the two installed segments 90° to balance the wheel while the third segment is installed. Rotate the wheel 180° again to install the fourth segment opposite the third. Repeat this sequence with the remaining four segments.

Polymer Wheel Drive Motor and Pulley Replacement

1. Disconnect power to wheel drive motor.
2. Remove belt from pulley and position temporarily around wheel rim.
3. Loosen set screw in wheel drive pulley using a hex head wrench and remove pulley from motor drive shaft.

4. While supporting weight of drive motor in one hand, loosen and remove (4) mounting bolts.
5. Install replacement motor with hardware kit supplied.
6. Install pulley to dimension as shown and secure set screw to drive shaft.
7. Stretch belt over pulley and engage in groove.
8. Follow start-up procedure.

Polymer Wheel Belt Replacement

1. Obtain access to the pulley side bearing access plate if bearing access plates are provided. Remove two bearing access plate retaining screws and the access plate.
2. Using hexagonal wrench, loosen set screw in bearing locking collar. Using light hammer and drift (in drift pin hole) tap collar in the direction of wheel rotation to unlock collar. Remove collar.
3. Using socket wrench with extension, remove two nuts which secure bearing housing to the bearing support beam. Slide bearing from shaft. If not removable by hand, use bearing puller.
4. Form a small loop of belt and pass it through the hole in the bearing support beam. Grasp the belt at the wheel hub and pull the entire belt down.

Note: Slight hand pressure against wheel rim will lift weight of wheel from inner race of bearing to assist bearing removal and installation.

CAUTION

Protect hands and belt from possible sharp edges of hole in Bearing Support Beam.

5. Loop the trailing end of the belt over the shaft (belt is partially through the opening).
6. Reinstall the bearing onto the wheel shaft, being careful to engage the two locating pins into the holes in the bearing support beam. Secure the bearing with two self-locking nuts.
7. Install the belts around the wheel and pulley according to the instructions provided with the belt.
8. Reinstall diameter seals or hub seal and tighten retaining screws. Rotate wheel in clockwise direction to determine that wheel rotates freely with slight drag on seals.
9. Reinstall bearing locking collar. Rotate collar by hand in the direction the wheel rotates (see label provided on each cassette for wheel rotation).
10. Lock in position by tapping drift pin hole with hammer and drift. Secure in position by tightening set screw.
11. Reinstall Bearing Access Cover.
12. Apply power to wheel and ensure that the wheel rotates freely without interference.

Energy Recovery Wheel General Cleaning
 Routine maintenance of the Energy Recovery Wheel includes periodic cleaning of the Energy Recovery Wheel as well as inspection of the Air Seals and Wheel Drive Components.

Cleaning the energy transfer media will help maintain optimal performance. The frequency of cleaning is largely dependent on the application and air quality. Use ASHRAE's Classes of Air categories, to create a routine cleaning schedule.

Class 1 air has low contaminant concentration with inoffensive odor and sensory irritation intensity.

Class 2 air has moderate contaminant concentration, with mildly offensive odors or sensory-irritation intensity.

Class 3 air has significant contaminant concentration and significant offensive odor or sensory-irritation intensity.

Class 4 air has highly objectionable fumes or gases and potentially contains dangerous particles, bio-aerosols, or gases at a concentration high enough to be considered harmful, not suitable for recirculation or transfer to any other space.

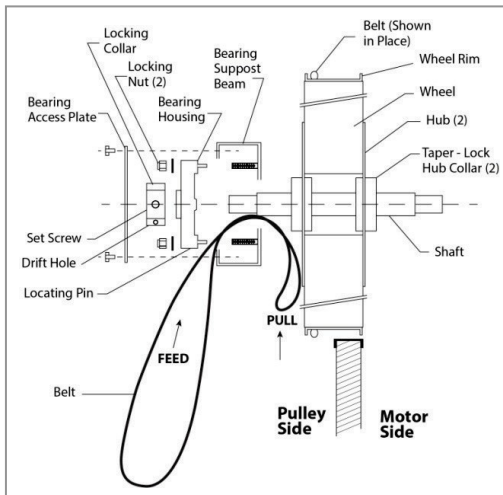

Belt Replacement

Table 30 - Energy Recovery Wheel Cleaning Frequency

| Class of Air | Examples | Cleaning Frequency |
|---------------------------------|---|--------------------------------|
| Class 1 Clean Air | <ul style="list-style-type: none"> • Offices • Classrooms • Assembly rooms • Churches | Every 8-10 years |
| Class 2 Moderately Clean Air | <ul style="list-style-type: none"> • Restrooms • Swimming pools • Dining rooms • Locker rooms • Warehouse • Dorms | Every 4-6 years |
| Class 3 Dirty Air | <ul style="list-style-type: none"> • Kitchens • Dry cleaners • Beauty salons • Laboratories • Pet shops | Every 1-2 years |
| Class 4 Contaminated Air | <ul style="list-style-type: none"> • Paint spray booths • Laboratory fume exhaust • Kitchen grease exhaust | Do not use in this application |

CAUTION

Disconnect electrical power before servicing energy recovery cassette. Always keep hands away from bearing support beam when installing or removing segments. Failure to do so could result in severe injury to fingers or hand.

The need for periodic cleaning of the energy recovery wheel will be a function of operating schedule, climate and contaminants in the indoor air being exhausted and the outdoor air being supplied to the building.

The energy recovery wheel is “self-cleaning” with respect to dry particles due to its laminar flow characteristics. Smaller particles pass through; larger particles land on the surface and are blown clear as the flow direction is reversed. Any material that builds up on the face of the wheel can be removed with a

brush or vacuum. The primary need for cleaning is to remove oil based aerosols that have condensed on energy transfer surfaces. A characteristic of all dry desiccants, such films can close off micron sized pores at the surface of the desiccant material, reducing the efficiency by which the desiccant can adsorb and desorb moisture and also build up so as to reduce airflow.

In a reasonably clean indoor environment such as a school or office building, measurable reductions of airflow or loss of sensible (temperature) effectiveness may not occur for several years. Measurable changes in latent energy (water vapor) transfer can occur in shorter periods of time in applications such as moderate occupant smoking or cooking facilities. In applications experiencing unusually high levels of occupant smoking or oil based aerosols such as industrial applications involving the ventilation of machine shop areas for example, annual washing of energy transfer

may be necessary to maintain latent transfer efficiency. Proper cleaning of the energy recovery wheel will restore latent effectiveness to near original performance.

Aluminum Wheel Cleaning

See general energy recovering cleaning section for how often to clean.

To clean, gain access to the aluminum energy recovery wheel then use the following methods:

- Use a brush or vacuum cleaner to remove small foreign materials.
- Use compressed air at a distance of at least .08 m (2 ft) from the wheel. Too much pressure can easily damage the aluminum media.
- First remove the energy recovery wheel from the unit. Then use water at a distance of at least .08 m (2 ft) from the wheel. Do not use detergents. Keep temperature below 25°C (77°F). Tightly cover all electric parts and bearings while used pressurized water. Remove excess water before reinstalling the wheel.

Polymer Wheel Cleaning

To clean, gain access to the energy recovery wheel and remove segments. Brush foreign material from the face of the wheel. Wash the segments or small wheels in a 5% solution of non-acid based coil cleaner or alkaline detergent and warm water.

CAUTION

Do not use acid based cleaners, aromatic solvents, steam or temperatures in excess of 76.7°C (170°F); damage to the wheel may occur!

Soak in the solution until grease and tar deposits are loosened (Note: some staining of the desiccant may remain and is not harmful to performance). Before removing, rapidly run finger across surface of segment to separate polymer strips for better cleaning action. Rinse dirty solution from segment and remove excess water before reinstalling in wheel.

Energy Recovery Wheel Defrost Timer

Setting

Set Mode to D

T1 is the on time

- Set T1 range to 10m (10 minutes)
- The scale should show 0-6 on the dial
- Set T1 dial to 3 which equals 30 minutes of run time

T2 is the off time

- Set T2 range to 1m (1 minute)
- The scale should show 0-6 on the dial
- Set T2 dial to 2 which equals 2 minutes of off time

Adjust temperature dial to set the point at which any temperature below will activate the defrost timer. Recommended setting is 1.7°C (35°F).

Once the OA Temperature goes below the setpoint, the wheel timer will stop for 2 minutes and run for 30 minutes and will continue to cycle at this rate as long as OA Temperature is below setpoint. If more off time is required to defrost the wheel, increase the T2 Knob time to a greater off time than 2 minutes.

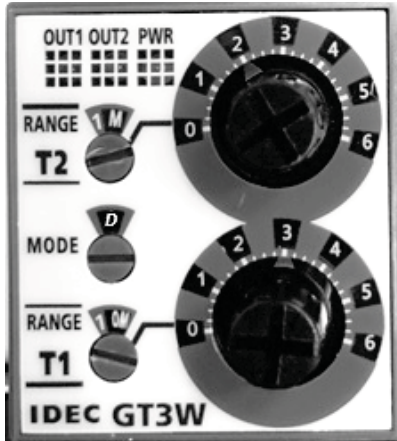

Figure 40 - Defrost Timer

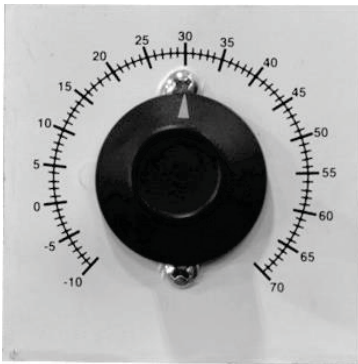

Figure 41 - Temperature Dial

Gas or Electric Heating

The unit is designed to heat a given amount of air while operating. If this amount of air is greatly reduced, approximately 1/3 during

the heating season, the gas heat exchanger or electric heating coil may overheat, and may cut the burner or heater off entirely by action of the safety high temperature limit devices which are factory mounted at the heat exchanger and supply fan areas.

Adjust airflow after installation to obtain an air temperature rise within the range specified on the unit rating plate at the required external static pressure.

Should overheating occur with a gas heat exchanger, or the gas supply fail to shut off, shut off the manual gas valve to the furnace before shutting off the electrical supply.

Prolonged overheating of the heat exchanger will shorten its life.

If unit has not been selected as a 100% outside air unit (makeup air unit) the return air duct must be sealed to the unit and the return air temperature must be maintained between 12.8°C (55°F) and 26.7°C (80°F).

Table 31 - Electric and Gas Heating Capacities

| Model Option B2 | Gas Heat | | Electric Heat | |
|--------------------|----------------|-----------------|---------------|----------------------------------|
| | Input Capacity | Output Capacity | Capacity | |
| | MBH | MBH | kW (208V) | kW (230V, 380V 460V, 575V) |
| 1 = Heat 1 | | | 7.5 | 10 |
| 2 = Heat 2 | 90.0 | 72.0 | 15.0 | 20 |
| 3 = Heat 3 | | | 22.5 | 30 |
| 4 = Heat 4 | 270.0 | 218.7 | 30.0 | 40 |
| 5 = Heat 5 | | | 37.5 | 50 |
| 6 = Heat 6 | 390.0 | 315.9 | 45.1 | 60 |
| 7 = Heat 7 | | | 60.1 | 80 |
| 8 = Heat 8 | 405.0 | 328.1 | 75.1 | 100 |
| 9 = Heat 9 | | | 90.1 | 120 |
| A = Heat A | | | 120.1 | 160 |
| B = Heat B | | | 150.2 | 200 |
| C = Heat C | 540.0 | 432.0 | 180.2 | 240 |
| D = Heat D | 810.0 | 648.0 | 210.3 | 280 |
| E = Heat E | 1080.0 | 864.0 | 240.3 | 320 |
| F = Heat F | 195.0 | 156.0 | | |
| G = Heat G | 292.5 | 234.0 | | |
| K = Heat K | 150.0 | 120.0 | | |
| L = Heat L | 210.0 | 168.0 | | |
| M = Heat M | 800.0 | 640.0 | | |
| N = Heat N | 1600.0 | 1280.0 | | |
| P = Heat P | 2400.0 | 1920.0 | | |

Electric Preheat

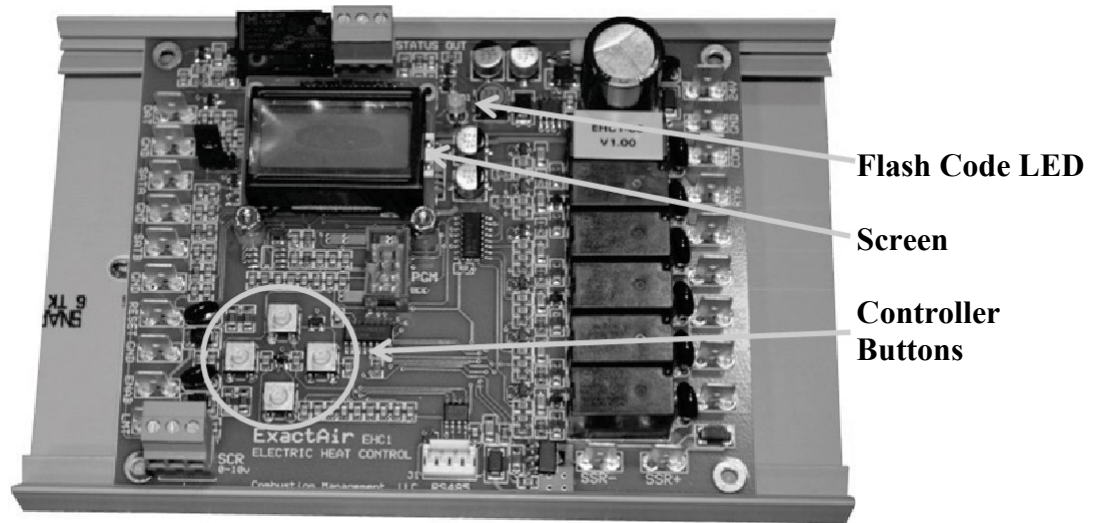

Figure 42 - Preheat Controller

The electric preheat controller is factory installed within the preheat cabinet. The following details are for EHC1 version 1.10 of the preheat controller.

Status Display Screens

These screens are access by pressing either the left or right controller buttons and scrolling through the following displays.

1. **LAT** - Measured leaving air temperature (LAT), average of LAT A and B probes.
MOD - Modulation rate % currently being applied to stage one SCR.

```
LAT XX.X
MOD XXX
```

2. **WKGset** - "Working" LAT setpoint (°F) (LATset>>RESETset as adjusted by 0-10V RESET signal).

```
WKGset
XXXX
```

3. **LATset** - Leaving air temperature (°F) control setpoint.

```
LATset
XXXX
```

4. **RESETset** - "Reset" air temperature (°F) control setpoint.

```
RESETset
XXXX
```

5. **OATset** - Outside air temperature (°F) control setpoint, measured outside temperature must be less to enable preheat.

```
OATset
XXXX
```

6. **LLTset** - "Low Limit Time" temperature (°F) setpoint. If this temperature is not reached at full output, relay will pull in.

```
LLTset
XXXX
```

7. **Stage** - Current operating stage 1-6.

```
Stage
X of X
```

8. **Stage** - Current operating stage 1-6.
MOD - Modulation rate % being applied to stage one heat strip SCR.

```
Stage X
MOD XX
```

9. **OAT** - Outside air inlet temperature(°F).

```
OAT
  XXX.X
```

10. **LATA** - Leaving air probe "A" temperature (°F).

```
LATA
  XX.X
```

11. **LATB** - Leaving air probe "B" temperature (°F).

```
LATB
  XX.X
```

12. **ManSTG** - Manual override stage for system testing. Any override automatically cancels after ten minutes; 0 indicates normal operation, 1-6 corresponds to stages 1-6 being forced on. Stage 1, the SCR, is forced to 50%.

```
ManSTG
  X
```

System Setting Screens

These screens are access by pressing the up button and then entering the technician password **2425**. The screens are scrolled through by pressing either right or left buttons on the controller. Adjustment is made by pressing the up and down buttons. After a short time of inactivity, the screen will go back to the Status Display Screens.

1. **StartDly** - Seconds of delay after the 'Enable' call before heating starts. This is to allow the Supply Fan to come up to speed. Supply Fan VFD's have a 45 second ramp up time. Range = 1sec-60sec, and the default is 15sec.

```
StartDly
0015
```

2. **BelowLLT** - "Below Low Limit Time". Range = 10sec-1800sec, and the default is 10sec. If 'LLTset' temperature is not

reached within 'BelowLLT' after reaching full output, the status relay will operate.

```
BelowLLT
0010
```

3. **Stages** - Number of stages. Range = 1-6, and the default is 1. The number of stages can be determined using Table 28.

```
Stages
0001
```

Table 32 - Stages of Electric Preheat

| Tonnages | Feature 14B | Stages |
|--------------------------------------|-------------|--------|
| A Cabinet RN 6-8 and 10 tons | G = 10 kW | 1 |
| | J = 20 kW | |
| | K = 30 kW | 2 |
| | L = 40 kW | |
| B Cabinet RN 9 and 11-15 tons | M = 50 kW | 3 |
| | N = 60 kW | |
| | J = 20 kW | 1 |
| | K = 30 kW | |
| C Cabinet RN 16-25 and 30 tons | L = 40 kW | 2 |
| | M = 50 kW | |
| | N = 60 kW | 3 |
| | P = 70 kW | |
| D Cabinet RN 31-40 and 45 tons | Q = 80 kW | 4 |
| | R = 90 kW | |
| | S = 100 kW | 5 |
| | T = 110 kW | |
| | U = 120 kW | 6 |
| | | |

4. **LATset** - Leaving air temperature setpoint. Range = 35°F-80°F, and the default is 50°F.

```
LATset
0050
```

5. **OATset** - Outside air temperature setpoint. Range = 35°F-60°F, and the default is 35°F.

```
OATset
0035
```

6. **LLTset** - “Low Limit Time” temperature setpoint. Range = 35°F-50°F, and the default is 35°F. If ‘LLTset’ temperature is not reached within ‘BelowLLT’ time after reaching full output, the status relay will operate.

```
LLTset
0035
```

7. **RESETset** - “Reset Setpoint” temperature. Range = 35°F-80°F, and the default is 50°F.

```
RESETset
0050
```

8. **ManSTG** - Temporary manual override a specified stage testing, 0=normal operation, 1-6 to override corresponding stages. Range = 0-6, and the default is 0. The manual override may be used for unit testing of each stage. Stage 1 will be at 50% to test SCR and stages 2-6 will be full capacity. A manual override will expire in ten minutes if not manually cancelled by resetting ‘ManSTG’ back to zero.

```
ManSTG
0000
```

LED Flash Alarm Codes

The flashing red LED will be to the right of the screen. The number of blinks is described below. The LCD screen will also display the screens.

- 1 = LATA probe open/short

```
FLT: LAT
Probe A
```

- 2 = LATB probe open/short

```
FLT: LAT
Probe B
```

- 3 = OAT sensor open/short

```
FLT: OAT
Probe
```

- 4 = Leaving air temp over limit

```
FLT: LAT
Hi Limit
```

- 5 = Cooling down after hi limit event

```
Hi LAT
Cooldown
```

- 6 = LAT below low limit

```
LATbelow
Lo Limit
```

- 7 = Stage 1 only recovery after mechanical limit

```
Mech Lmt
Recovery
```

- 8 = Shutdown after too many hi limit events

```
Mech Lmt
Shutdown
```

- 9 = Short or overload on the 0-10VDC analog signal output

```
FLT: SCR
0-10 Sig
```

Operation

Controller receives 24VAC preheat enable

Controller evaluates if outside air temperature “OAT” is below setpoint ‘OATset’

If $OAT < 'OATset'$, controller will delay heating startup by time setpoint ‘STARTDLY’, then stage up preheat to maintain the setpoint ‘LATset’ to a maximum number of stages set in setpoint ‘Stages’.

If a safety is reached with the controller’s safety sensors then the electric preheat will be de-energized for a period of 2 minutes. Electric preheat will turn on stage one at 100% for 3 minutes to test if fault conditions still exist after the cool down period. The controller will repeat this and if 3 trips are recorded in 60 minutes then the controller will lockout and require manually cycling power to reset.

The modulating electric preheat option is designed to temper the incoming outside air to the unit based on an enable control signal and the outside air conditions.

A 24VAC enable signal must be provided to the [PHE] terminal to enable the operation of the electric preheat. Once the preheat controller is enabled it will monitor the outside air temperature to determine if any capacity of preheat is needed. If the outside air temperature falls below the outside air temperature setpoint the electric preheat will be started up and maintain the leaving air temperature setpoint with both SCR controlled and staged electric preheat. Both setpoints are set with push button LCD interface on the preheat controller. Outside air temperature sensors and preheat discharge supply air temperature sensors are factory

installed and wired to the preheat controller. Electric preheat has maximum operating outside air temperature of 15.6°C (60°F) and a maximum preheat discharge air temperature of 26.7°C (80°F).

[COM], [PHO] & [PHC] feedback terminals are provided to communicate if the electric preheat is in operation. PHO is a normally open contact, PHC is a normally closed contact, and COM is the common. These terminals are not required to be connected. [PHE] is the electric preheat operation enable. [PH+] and [PH-] are the preheat set point reset terminals.

Gas Heating

Verify the unit nameplate agrees with the proper gas supply type and amount.

Gas piping shall be installed in accordance with local codes, or in the absence of local codes, installation shall conform to the current (United States) National Fuel Gas Code ANSI-Z223.1/NFPA 54 or the current (Canada) National Fuel & Propane Installation Code CSA B149.1 or B149.2.

WARNING

FOR YOUR SAFETY

Read the entire gas heating installation section of this manual before beginning installation of the gas heating section.

If instructions are not followed as exactly stated, a fire or explosion may result causing property damage, personal injury, or loss of life.

Table 33: 6 – 30 ton Gas Connections

| Cabinet Size | Staging | Capacity (MBH) | Gas Valve QTY | Valve 1 Size | Valve 2 Size | Valve 3 Size | Valve 4 Size | Valve 5 Size | Valve 6 Size |
|--------------|-----------|----------------|---------------|--------------|--------------|--------------|--------------|--------------|--------------|
| RNA | 1, 2, MOD | 90 | 1 | 1/2" | - | - | - | - | - |
| | 4, HITD | | 2 | 1/2" | 1/2" | - | - | - | - |
| | 1, 2, MOD | 150 | 1 | 1/2" | - | - | - | - | - |
| | 4, HITD | | 2 | 1/2" | 1/2" | - | - | - | - |
| | 1, 2, MOD | 210 | 1 | 1/2" | - | - | - | - | - |
| | 4, HITD | | 2 | 1/2" | 1/2" | - | - | - | - |
| RNB | 1, 2, MOD | 195 | 1 | 3/4" | - | - | - | - | - |
| | 4, HITD | | 2 | 3/4" | 3/4" | - | - | - | - |
| | 1, 2, MOD | 292.5 | 1 | 3/4" | - | - | - | - | - |
| | 4, HITD | | 2 | 3/4" | 3/4" | - | - | - | - |
| | 1, 2, MOD | 390 | 1 | 3/4" | - | - | - | - | - |
| | 4, HITD | | 2 | 3/4" | 3/4" | - | - | - | - |
| RNC | 2, MOD | 270 | 1 | 3/4" | - | - | - | - | - |
| | 4, HITD | | 2 | 1/2" | 3/4" | - | - | - | - |
| | 2, 4, MOD | 405 | 2 | 3/4" | 3/4" | - | - | - | - |
| | HITD | | 3 | 1/2" | 3/4" | 3/4" | - | - | - |
| | 2, 4 MOD | 540 | 2 | 3/4" | 3/4" | - | - | - | - |
| | HITD | | 3 | 1/2" | 3/4" | 3/4" | - | - | - |

MOD = Modulating, HITD = High Turndown

After verifying gas inlet pressure and manifold pressure the service technician shall time the gas flow rate through the gas meter with a stopwatch to verify the gas input rate.

Unit nameplate input rate value has been calculated at the altitude where the unit was shipped. Above 609.6 m (2,000 ft)., the input rate is adjusted 4% for every 304.8 m (1000 ft).

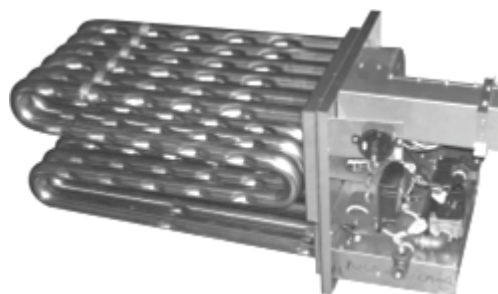

Figure 43- RN Series Gas Heat Exchanger

Table 34 - Natural Gas (m³/hr [ft³/hr]) Maximum Piping Capacities Specific
Gravity = 0.6, Supply Pressure ≤ 3.5 kpa (0.5 psi), Pressure Drop = .93 mmHg (0.5" w.c).

| Pipe Size (mm [in.]) | Length of Pipe (m [ft]) | | | | |
|-------------------------|-------------------------|-------------|-------------|------------|-------------|
| | 6.1 (20) | 15.2 (50) | 30.4 (100) | 45.6 (150) | 60.8 (200) |
| 12.7 (1/2") | 3.4 (120) | 2 (73) | 1.4 (50) | 1.1 (40) | 1 (35) |
| 19 (3/4") | 7 (250) | 4.2 (151) | 2.9 (103) | 2.4 (84) | 2 (72) |
| 25.4 (1") | 13 (465) | 8 (285) | 5.5 (195) | 4.5 (160) | 3.8 (135) |
| 31.75 (1-1/4") | 26.6 (950) | 16.2 (580) | 11.2 (400) | 9.1 (325) | 7.8 (280) |
| 38.1 (1-1/2") | 40.9 (1460) | 25.2 (900) | 17.4 (620) | 14 (500) | 12 (430) |
| 50.8 (2") | 77 (2750) | 47 (1680) | 32.2 (1150) | 26.6 (950) | 22.4 (800) |
| 63.5 (2-1/2") | 121.8 (4350) | 74.2 (2650) | 51.8 (1850) | 42 (1500) | 35.8 (1280) |

Table 35 - Propane (kW [kBtu/hr]) Maximum Piping Capacities Specific
Gravity = 1.52, Supply Pressure = 20.6 mmHg (11" w.c.), Pressure Drop, .93 mmHg (0.5" w.c).

| Pipe Size (mm [in.]) | Length of Pipe (m [ft]) | | | | |
|-------------------------|-------------------------|------------|------------|------------|------------|
| | 6.1 (20) | 15.2 (50) | 30.4 (100) | 45.6 (150) | 60.8 (200) |
| 12.7 (1/2") | 0.6 (189) | 0.4 (114) | 0.3 (78) | 0.2 (63) | 0.2 (55) |
| 19 (3/4") | 1.3 (393) | 0.8 (237) | 0.6 (162) | 0.5 (132) | 0.4 (112) |
| 25.4 (1") | 2.5 (732) | 1.5 (448) | 1.0 (307) | 0.9 (252) | 0.7 (213) |
| 31.75 (1-1/4") | 5.1 (1496) | 3.1 (913) | 2.1 (630) | 1.7 (511) | 1.5 (440) |
| 38.1 (1-1/2") | 7.8 (2299) | 4.8 (1417) | 3.3 (976) | 2.7 (787) | 2.3 (675) |
| 50.8 (2") | 14.8 (4331) | 9.0 (2646) | 6.2 (1811) | 5.1 (1496) | 4.3 (1260) |

Do not use gas piping smaller than unit gas connections. Natural gas pipe that runs longer than 6.1 meters (20 feet) and propane gas pipe that runs longer than 15.2 meters (50 feet) may require a larger supply pipe than the unit connection size. Some utility companies may also require pipe sizes larger than the minimum sizes listed.

Piping Sizing Examples

A 100 ft pipe run is needed for a 1080 MBH natural gas heater. The natural gas has a rating of 1000 Btu/ft³ (Obtain these values from the local gas supplier.)

$$1080 \text{ MBH} \times \frac{\text{ft}^3}{1000 \text{ BTU}} = 1080 \text{ ft}^3/\text{hr}$$

From the natural gas maximum capacities table, at 100 ft and 1080 ft³/hr the required minimum pipe size is 2".

A 100 ft pipe run is needed for a 270 MBH propane gas heater.

$$270 \text{ MBH} = 270 \text{ kBtu/hr}$$

From the propane gas maximum capacities table, at 100 ft and 270 kBtu/hr the required minimum pipe size is 25.4 mm (1").

Inlet and Manifold Pressures

For natural gas units, the minimum inlet gas pressure to the unit is 11.2 mmHg (6" w.c.) and maximum inlet gas pressure to the unit is 19.6 mmHg (10.5" w.c.) For propane units, the minimum inlet gas pressure to the unit is 20.6 mmHg (11" w.c.) and the maximum inlet gas pressure to the unit is 24.3 mmHg (13" w.c.) A field provided 0.3 cm (1/8") NPT pressure tap is required to be installed in the piping just upstream of the shutoff valve for test gage connection to allow checking of the gas supply pressure at the unit.

A factory installed pressure tap on the outlet end of the gas valve can be used to verify a manifold pressure of 6.5 mmHg (3.5" w.c.) for natural gas, or 19.6 mmHg (10.5" w.c.) for propane.

| |
|---|
|  CAUTION |
| <p>Heater must be disconnected from the gas supply piping during pressure testing of the supply piping system with pressures in excess of 3.45 kpa (½ psi). Gas valves can be damaged if subjected to more than 3.45 kpa (½ psi).</p> |

Gas Pressure Regulator & Overpressure Protection Device

A gas pressure regulator shall be installed if natural gas supply pressure to the unit is greater than 19.6 mmHg (10.5" w.c.) and less than 13.8 kpa (2 psi) (103.5 mmHg [55.4" w.c.]) and if propane gas supply pressure is greater than 24.3 mmHg (13" w.c.) and less than 13.8 kpa (2 psi) (103.5 mmHg [55.4" w.c.]). Regulators shall comply with the latest edition of the Standard for Line Pressure Regulators, ANSI Z21.80/CSA 6.22.

Both a gas pressure regulator and overpressure protection device (OPD) shall be installed if gas supply pressure to the unit is greater than 13.8 kpa (2 psi) (103.5 mmHg [55.4" w.c.]) and less than 34.5 kpa (5 psi) (258.57 mmHg [138.4" w.c.]), in compliance with ANSI Z21.80/CSA 6.22. For proper heater operation, pressure to the regulator SHALL NOT be greater than 34.5 kpa (5 psi) (258.57 mmHg [138.4" w.c.]).

Piping Supports

Gas supply piping shall be supported directly at the connection to the unit and at intervals listed in the following table with metal straps,

blocks, or hooks. Piping shall not be strained or bent.

Table 36 - Gas Piping Supports (Metric)

| Pipe Size (mm) | Support Intervals |
|-----------------------------|-------------------|
| 12.7 to 19.1 | Every 1.8 m |
| 19.1 to 25.4 | Every 2.4 m |
| 44.5 or Larger (Horizontal) | Every 3 m |
| 31.75 or Larger (Vertical) | Every Floor |

Table 37 – Gas Piping Supports (Imperial)

| Pipe Size | Support Intervals |
|-------------------------------|-------------------|
| 1/2" to 3/4" | Every 6 ft |
| 3/4" to 1" | Every 8 ft |
| 1-3/4" or Larger (Horizontal) | Every 10 ft |
| 1-1/4" or Larger (Vertical) | Every Floor |

Additional Gas Piping Considerations

Local codes will usually require a field provided and installed manual main shutoff valve and union external to the unit. Main shutoff valve shall be labeled. Install a drip leg near the unit connection to trap sediment and condensate. Pipe joint compounds used on all gas piping connections shall be resistant to liquid petroleum gases.

Heat exchanger comes equipped with a condensate drain which shall be plumbed to the appropriate drain according to the (United States) National Fuel Gas Code ANSI-Z223.1/NFPA 54 or the current (Canada) National Fuel & Propane Installation Code CSA B149.1 or B149.2, the International Building Code, and any applicable local and regional codes and regulations.

The condensate drain connection is located next to the gas entry location. For 6-30, ton units, the heat exchanger condensate drain connection from the unit is a 1.6 cm (5/8") barbed nylon elbow

connection.

AAON gas fired heat exchangers are designed to be non-condensing. These heat exchangers are mounted downstream of the cooling coils. During the cooling season the ambient air inside the heat exchanger tubes can condense due to cold air being blown over the outside of the tubes. The amount of condensation will vary depending on the ambient air temperature and humidity as well as air temperature over the tubes. This condensation can be drained onto the roof or into any waste drain.

Typically during the heating season the heat exchanger will not make any condensation. However, short-cycling of the heater can prevent the flue gases from reaching temperatures above dew point (about 54.4°C [130°F]) which can cause condensation in the heat exchanger.

Staged or modulated heat exchangers may produce condensate depending on the firing rate, ambient air temperature and humidity as well as the percentage and temperature of outside air being introduced to the unit. This condensate is generally between a 2.9 and 4 pH level.

Condensation made in the heat exchanger during the heating mode may need to be

managed and not just drained onto the roof depending on national and local code requirements and the application of the final user. This condensate can stain the roof and it can cause rust in some cases on metal roofs. It must be determined by a qualified technician if the condensate will damage the roofing material before unit startup.

Below freezing ambient air temperatures during the heating mode can freeze any condensation made in the drain lines. Smaller amounts of condensation may not cause any issues but for larger amounts of condensate and low ambient air temperatures (below freezing for multiple consecutive days) the internal and external drain lines for the unit will need to be heat traced to prevent freezing. Heat traced internal drain lines are required and a factory provided standard feature on the condensate drain with the high turndown modulating gas option.

A condensate neutralizer vessel and connecting tubing can be added to the equipment if required. For below freezing ambient temperature applications the neutralizer, connecting tubing and drain lines will require heat tracing to prevent condensate freezing. A qualified technician must determine if these components are necessary before unit startup.

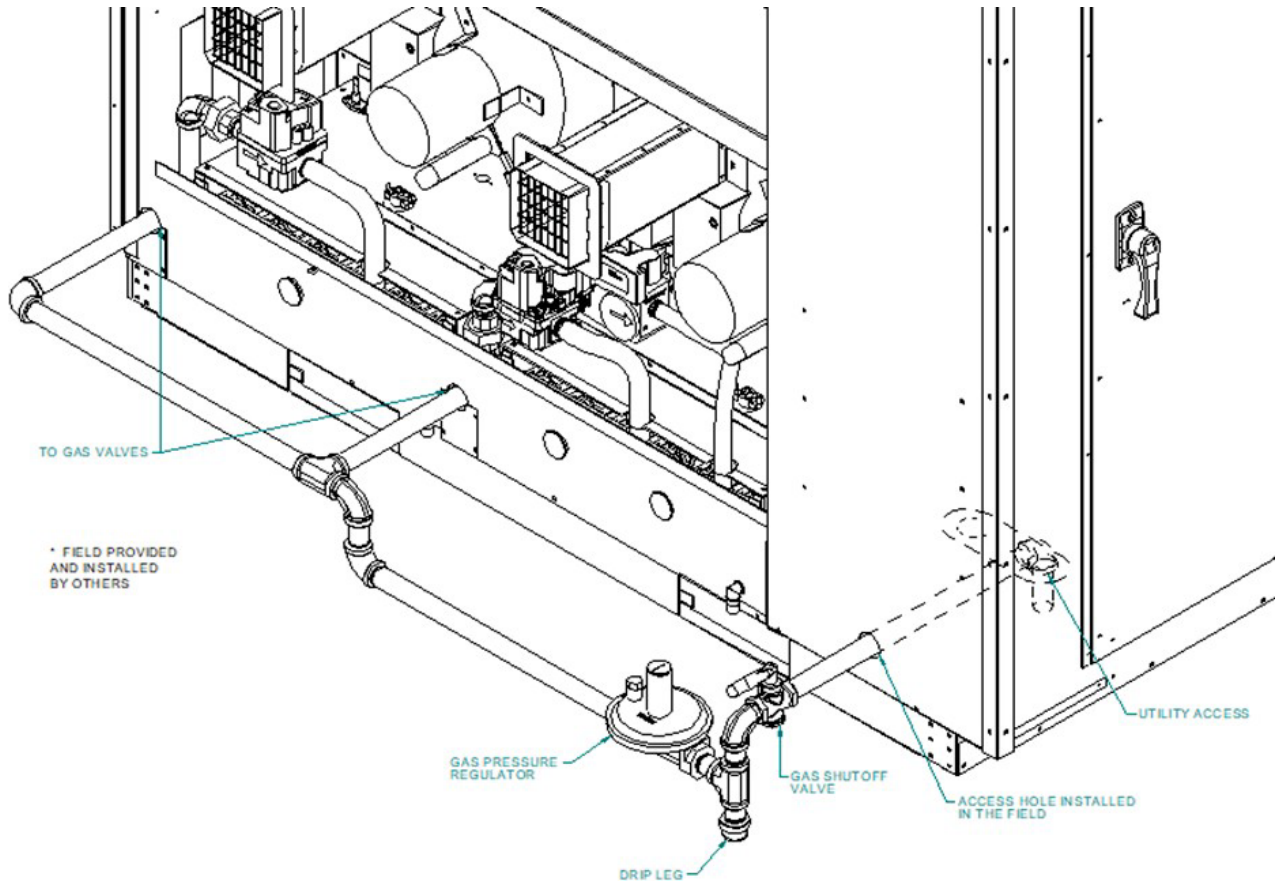

Figure 44 - Example 6-30 ton External Gas Piping

Leak Testing

All components of gas supply system, including manual shut off valves and the piping in the interior of the unit, must be leak tested. At a minimum, the “Bubble Leak Test” must be performed before operating the appliance, as well as, on an annual basis thereafter, if not more frequently. All leak testing must be performed in accordance with this instruction manual as well as in accordance to the National Fuel Gas Code NFPA 54/ANSI-Z223.1, CSA B149.1 (Canada) and local codes as applicable.

Bubble Leak Test

Test is performed using a soap solution leak detector solution. With electrical power to the unit terminated and the gas supply to the unit within the specified pressures provided in this IOM, the solution is sprayed at each threaded connection of the gas supply piping to the unit and internal gas train of the unit. Each connection is observed for bubbles, which indicates leaks in the connection. Joints with bubbles appearing during the check must be inspected for thread engagement and/or damage and tightened as needed.

DANGER

LEAK CHECK GAS PIPE

The gas pipe in the unit shall be checked for leaks before operation and startup. Unit must not be placed in operation until a leak check has been conducted for all gas piping connections. All connections shall be checked for leaks annually after installation. Gas leaks could result in fire, explosion, or other hazardous situations.

DANGER

Do not use open flame or other source of ignition for leak testing. Fire or explosion could result causing property damage, personal injury, or death.

CAUTION

Some soaps used for leak detection can be corrosive to certain metals. Rinse piping thoroughly after leak test has been completed.

All gas fired heat exchangers are completely tested at the factory before shipment. This will remove nearly all of the oils that have been used in the manufacturing process. However, trace amounts may remain. When performing the initial startup at the jobsite, it is highly recommended that people or any other living animals, which may be sensitive to the residual odors or gases, NOT be present in the conditioned space during the startup. In all cases, including the initial factory firing and testing, any of the gases will be under the acceptable level of concentration for human occupancy.

WARNING

Those sensitive to odors or gases from trace amounts of residual oils must NOT be present in the conditioned space during the startup of a gas fired installation.

FOR YOUR SAFETY READ BEFORE OPERATING

WARNING: IF YOU DO NOT FOLLOW THESE INSTRUCTIONS EXACTLY, A FIRE OR EXPLOSION MAY RESULT CAUSING PROPERTY DAMAGE, PERSONAL INJURY OR LOSS OF LIFE.

- A. This appliance does not have a pilot. It is equipped with an ignition device which automatically lights the burner. Do not try to light the burner by hand.
 - B. BEFORE OPERATING smell all around the appliance area for gas. Be sure to smell next to the floor because some gas is heavier than air and will settle on the floor.
- WHAT TO DO IF YOU SMELL GAS**
- Do not try to light any appliance.
 - Do not touch any electric switch; do not use any phone in your building.
 - Immediately call your gas supplier from a neighbor's phone. Follow the gas supplier's instructions.
 - If you cannot reach your gas supplier, call the fire department.
- C. Use only your hand to move the on/off switch.
 - D. Do not use this appliance if any part has been under water. Immediately call a qualified service technician to inspect the appliance and to replace any part of the control system and any gas control which has been under water.

OPERATING INSTRUCTIONS

1. STOP! Read the safety information above this label.
2. Set the thermostat to lowest setting.
3. Turn off all electric power to the appliance.
4. This appliance is equipped with an ignition device which automatically lights the burner. Do not try to light the burner by hand.
5. Remove control access panel.
6. Move the on/off switch to the "OFF" position.
7. WAIT five (5) minutes to clear out any gas. If you then smell gas, STOP! Follow "B" in the safety information above on this label. If you don't smell gas, go to the next step.
8. Move the on/off switch to the "ON" position.
9. Replace control access panel.
10. Turn on all electric power to the appliance.
11. Set thermostat to desired setting.
12. If the appliance will not operate, follow the instructions "To Turn Off Gas to Appliance" and call your service technician or gas supplier.

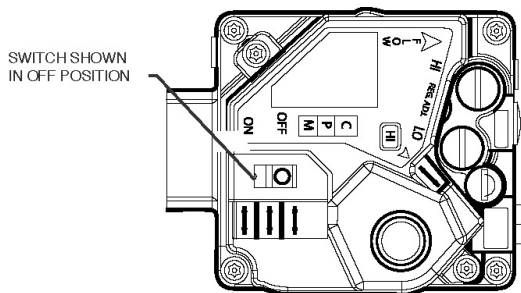

TO TURN OFF GAS TO APPLIANCE

1. Set the thermostat to lowest setting.
2. Turn off all electric power to the appliance if service is to be performed.
3. Remove control access panel.
4. Move the on/off switch to the "OFF" position.
5. Replace control access panel.

Direct Ignition • P72570

Figure 58 - Gas Heater Instructions

 **WARNING**

Once a year, before the unit is in operation for the heating season, a qualified service technician must inspect all flue product carrying areas of the furnace and main burners for continued safe operation.

 **DANGER**

LEAK CHECK GAS PIPE

The gas pipe in the unit must be checked for leaks before operation and startup. Unit must not be placed in operation until a leak check has been conducted for all gas piping connections. All connections shall be checked for leaks annually after installation. Failure to leak check could result in fire, explosion, or other hazardous situations.

Make sure all gas supply lines have been purged of air before turning on the electrical power switch. Turn the gas valve to the on position (see startup instructions). Turn the main electrical power on and set the controls to the heating mode of operation.

The combustion ventilation motor will enable. The control will automatically supply energy to the igniter and the gas valve after the heating call is made.

The flame sensing probe detects the presence of the flame. Should no flame be detected in 10 seconds, the ignition system will recycle. If no flame is detected after 3 tries, ignition system will lockout.

Remove the call for heating. The main gas valves shall be extinguished.

The supply fans are controlled by the ignition system. In the fan “Auto” mode the fan comes on 45 seconds after the flame is proved and goes off 120 seconds after the heating call is removed.

Furnace combustion ventilation air and flue openings shall be checked annually for debris and obstructions. If vent extensions are used they shall meet category III requirements.

This appliance contains a wire screen at the vent outlet. Each heating season, prior to placing the appliance in heat mode, maintenance check that no debris or foreign matter has accumulated in the vent outlet. A good practice is to check for debris each time the air filters are changed.

In the event the vent outlet becomes blocked do not attempt to start the appliance in heat mode until the entire vent opening is cleared.

In the event the unit shut down because the vent was blocked, a qualified technician or service agency shall monitor the unit prior to re-starting.

The gas burner and heat exchanger shall never require cleaning. If cleaning is necessary, this indicates faulty operation of the unit. Cleaning shall only be done by a qualified service agency and only after consultation with an AAON service representative.

If induced draft blower/motor assembly has to be replaced, care must be taken to provide an airtight seal between the blower housing and the burner box.

Gas Heat Exchanger Removal

WARNING

Electric shock hazard. Shut off all electrical power to the unit to avoid shock hazard, injury, or death from rotating parts.

Removal

Verify that the unit power has been switched off.

Disconnect all wiring on the heat exchanger.

Shut off all gas valves to the unit.

Remove screws on plate below the door covering the pipes exiting the heat exchanger.

Remove only the outermost screws around the perimeter of the heat exchanger face plate that connect it to the unit.

Pull the heat exchanger straight back and out of the unit. It may be necessary to remove some of the control door jambs.

Reinstallation

Ensure that the neoprene isolator is installed around the perimeter of the heat exchanger.

Insert heat exchanger into opening so that the back of the main plate is against the unit bulkhead.

Attach the heat exchanger to the unit using the holes around the perimeter.

Attach bottom plate back over the external piping.

Connect wiring per the wiring diagram on the controls compartment door.

Purge gas lines to the gas valves at the unit.

DANGER

LEAK CHECK GAS PIPE

The gas pipe in the unit must be checked for leaks before operation and startup. Unit must not be placed in operation until a leak check has been conducted for all gas piping connections. All connections shall be checked for leaks annually after installation. Failure to leak check could result in fire, explosion, or other hazardous situations.



Figure 45 – RN Gas Heat Exchanger

Phase and Brownout Protection Module



The DPM is a Digital Phase Monitor that monitors line voltages from 200VAC to 240VAC 1 ϕ and 200VAC to 600VAC 3 ϕ . The DPM is 50/60 Hz self-sensing. DPM must be wired according to unit specific wiring diagram include in the control compartment

When the DPM is connected to the line voltage, it will monitor the line and if everything is within the setup parameters, the output contacts will be activated. If the line voltages fall outside the setup parameters, the output relay will be de-energized after the trip delay.

Once the line voltages recover, the DPM will re-energize the output relay after the restart time delay. All settings and the last 4 faults are retained, even if there is a complete loss of power.

DPM Setup Procedure

With the supply voltage active to the module, you can setup all of the DPM's settings without the line voltage connected.

To change the setpoint parameters use the right arrow key to advance forward through

the setpoint parameters and the left arrow to backup if needed. When each parameter is displayed use the up/down keys to change and set the parameter.

After adjustments are made or if no adjustments are made it will take 2 to 4 minutes before the DPM energizes the output relay unless there is an out of tolerance issue with the incoming line voltage.

Recommended Default Set-up

| | |
|---------------------|------------------|
| Line Voltage | 460VAC, 3 ϕ |
| Over & Undervoltage | \pm 10% |
| Trip Time Delay | 5 Seconds |
| Re-Start Time Delay | 2 Minutes |
| Phase Imbalance | 5% |



Phase and brownout module may be this type on some products (as seen in the above picture). No setup is needed with this module version, other than checking that the voltage jumper voltage matches the unit voltage

Screens

Manufacturer's Screen

R-K Electronics

DPM v0.0.00

Average Voltage Screen

| VAvg | Imb | Hz | |
|------|-----|----|-----|
| 460 | 0 | 60 | off |

Default – the default screen shows the real time voltage detected in each of the 3 phases:

| A-B | B-C | C-A | |
|-----|-----|-----|----|
| 460 | 459 | 461 | ON |

Voltage Selection Screen (Vertical Format) Default = 460V, 3Ø

200, 1Ø; 208, 1Ø; 220, 1Ø; 230, 1Ø; 240, 1Ø;
200, 3Ø; 208, 3Ø; 220, 3Ø; 230, 3Ø; 240, 3Ø; 380, 3Ø; 415, 3Ø; 440, 3Ø;
460, 3Ø; 480 3Ø; 575, 3Ø; 600, 3Ø;

Over/Under voltage Percentage Screen (Vertical Format) Default = 10%

7% 8% 9% 10% 11% 12% 13% 14% & 15%

Trip Time Delay Screen (Vertical Format) Default = 5 sec

2S, 3S, 4S, 5S, 6S, 27S, 8S, 9S & 10S

Re-Start Time Delay Screen (Vertical Format) Default = 2 sec

Manual, 2S, 3S, 4S, 5S, 6S, 7S, 8S, 9S, 10S, 30S, 1M, 2M, 3M & 4M

Phase Imbalance Percentage Screen (Vertical Format) Default = 5%

3% 4% 5% 6% 7% 8% 9% & 10%

Fault Screen (Vertical Format)

“0” most recent faults, “1” previous fault “2” third oldest fault & “3” fourth oldest fault.

Fault Words:

| | |
|----------------|---|
| “Phase a Loss” | (There is no voltage sensed on 3-L1/S) |
| “Voltage Low” | (Average line voltage is less than selected Undervoltage Percentage) |
| “Voltage High” | (Average line voltage is more than selected Overvoltage Percentage) |
| “Imbalance” | (One phase is lower than the average voltage by more than the Imbalance percentage) |
| “Phase Loss | (One phase is more than 30% below the Line Voltage selection) |
| “Bad Rotation” | (The phase rotation sequence is reversed) |
| “Bad Freq” | (Line frequency out of allowable range of 45 to 65 Hz) |

Filter Replacement

Monthly air filter inspection is required to maintain optimum unit efficiency.

WARNING

Electric shock hazard. Shut off all electrical power to the unit to avoid shock hazard or injury or death from rotating parts.

It is strongly recommended that filter media be replaced monthly. Filters are located upstream of the evaporator coil in the filter and economizer section. Open access door and pull filters straight out to inspect all of the filters. Replace filters with the size indicated on each filter or as shown in the tables below. Arrow on the replacement filters must point towards the blower.

(RAB = Return Air Bypass, PE = Power Exhaust and PR = Power Return)

Table 38- 6-8 and 10 ton Pre Filters

| Feature 6A | Qty. Size [inches.] | Type |
|------------|---|-------------------------|
| 0 | No Pre Filters | |
| A, E, F, H | (4) 16 x 20 x 2] | Pleated, MERV 8 |
| B, E, G, H | (2) 16 x 20 x 1 | Metal Mesh, Outside Air |
| C | (2) 40 x 16 x 5/16 | Lint Screen |
| | with RAB, Feature A2 = Q, R (2) 40 x 16 x 5/16 | |

Table 39 - 9 and 11-15 ton Pre Filters

| Feature 6A | Qty. Size [inches.] | Type |
|------------|---|-------------------------|
| 0 | No Pre Filters | |
| A, E, F, H | (4) 20 x 25 x 2 | Pleated, MERV 8 |
| B, E, G, H | (2) 20 x 25 x 1 | Metal Mesh, Outside Air |
| C | (2) 49 x 20 x 5/16 | Lint Screen |
| | with RAB, Feature A2 = Q, R (3) 47 x 12 x 5/16 | |

Table 40 - 14, 16-25 and 30 ton Pre Filters

| Feature 6A | Qty. Size [inches.] | Type |
|------------|---|-------------------------|
| 0 | No Pre Filters | |
| A, E, F, H | (6) 20 x 25 x 2 | Pleated, MERV 8 |
| B, E, G, H | (3) 20 x 25 x 1 | Metal Mesh, Outside Air |
| C | (2) 55 x 25 x 5/16 | Lint Screen |
| | with RAB, Feature A2 = Q, R (3) 55 x 16 x 5/16 | |

Table 41 - 6-8 and 10 ton Unit Filters

| Feature 6B | Quantity / Size | Type |
|------------|---|---|
| 0 | 4 / 16" x 20" x 2" | Pleated, MERV 8 |
| | with RAB, Feature A2 = Q, R 2 / 20" x 20" x 2" and 1/12" x 24" x 2" | |
| B | 4 / 16" x 20" x 4" | Pleated, MERV 8 |
| | with RAB, Feature A2 = Q, R 2 / 20" x 20" x 4" and 1/12" x 24" x 4" | |
| C | 4 / 16" x 20" x 2" | Permanent Filter Frame - Replaceable Media |
| | with RAB, Feature A2 = Q, R 2 / 20" x 20" x 2" and 1/12" x 24" x 2" | |
| F | 4 / 16" x 20" x 4" | Pleated, MERV 11 |
| G | | Pleated, MERV 13 |
| H | | Pleated, MERV 14 |

Table 42 - 9 and 11 ton Unit Filters

| Feature 6B | Quantity / Size | Type |
|------------|---|---|
| 0 | 4 / 20" x 25" x 2" | Pleated, MERV 8 |
| | with RAB, Feature A2 = Q, R 6 / 12" x 24" x 2" | |
| B | 4 / 20" x 25" x 4" | Pleated, MERV 8 |
| | with RAB, Feature A2 = Q, R 6 / 12" x 24" x 4" | |
| C | 4 / 20" x 25" x 2" | Permanent Filter Frame - Replaceable Media |
| | with RAB, Feature A2 = Q, R 6 / 12" x 24" x 2" | |
| F | 4 / 20" x 25" x 4" | Pleated, MERV 11 |
| G | | Pleated, MERV 13 |
| H | | Pleated, MERV 14 |

Table 43 - 13 and 15 ton Unit Filters

| Feature 6B | Quantity / Size | Type |
|------------|---|---|
| 0 | 4 / 20" x 25" x 2" | Pleated, MERV 8 |
| | with RAB, Feature A2 = Q, R 6 / 12" x 24" x 2" | |
| B | 4 / 20" x 25" x 4" | Pleated, MERV 8 |
| | with RAB, Feature A2 = Q, R 6 / 12" x 24" x 4" | |
| C | 4 / 20" x 25" x 2" | Permanent Filter Frame - Replaceable Media |
| | with RAB, Feature A2 = Q, R 6 / 12" x 24" x 2" | |
| F | 4 / 20" x 25" x 4" | Pleated, MERV 11 |
| G | | Pleated, MERV 13 |
| H | | Pleated, MERV 14 |

Table 44 - 14, 16-25 and 30 ton Unit Filters

| Feature 6B | Quantity / Size | Type |
|------------|---|---|
| 0 | 6 / 20" x 25" x 2" | Pleated, MERV 8 |
| | with RAB, Feature A2 = Q, R 9 / 16" x 20" x 2" | |
| B | 6 / 20" x 25" x 4" | Pleated, MERV 8 |
| | with RAB, Feature A2 = Q, R 9 / 16" x 20" x 4" | |
| C | 6 / 20" x 25" x 2" | Permanent Filter Frame - Replaceable Media |
| | with RAB, Feature A2 = Q, R 9 / 16" x 20" x 2" | |
| F | 6 / 20" x 25" x 4" | Pleated, MERV 11 |
| G | | Pleated, MERV 13 |
| H | | Pleated, MERV 14 |

Table 45 - 6-8 and 10 ton Energy Recovery Wheel Filters

| Feature 1A | Quantity / Size | Type |
|------------------------|---|-----------------|
| F, G, H, J, Q, R, S, T | (Prior to August 2014) 1 / 25" x 16" x 4" | Pleated, MERV 8 |
| | (Prior to August 2014) With Energy Recovery Wheel Exhaust Air Filters, Feature 6A - D, F, G, H OA - 1 / 25" x 16" x 2" EA - 1 / 25" x 16" x 2" | |
| | (After August 2014) With V-Bank Outside Air Filters OA - 2 / 25" x 14" x 2" | |
| | (After August 2014) With Energy Recovery Wheel Exhaust Air Filters, Feature 6A - D, F, G, H OA - 2 / 25" x 14" x 2" EA - 1 / 25" x 16" x 2" | |

Table 46 - 9 and 11-15 ton Energy Recovery Wheel Filters

| Feature 1A | Quantity / Size | Type |
|---|---|-----------------|
| F, G, H, J, Q, R, S, T, U, V, W, Y, Z, 1, 2, 3 | (Prior to August 2014) 2 / 16" x 20" x 4" | Pleated, MERV 8 |
| | (Prior to August 2014) With Energy Recovery Wheel Exhaust Air Filters, Feature 6A - D, F, G, H OA - 2 / 16" x 20" x 2" EA - 2 / 16" x 20" x 2" | |
| | (After August 2014) With V-Bank Outside Air Filters OA - 4 / 20" x 12" x 2" | |
| | (After August 2014) With Energy Recovery Wheel Exhaust Air Filters, Feature 6A - D, F, G, H OA - 4 / 20" x 12" x 2" EA - 2 / 16" x 20" x 2" | |

Table 47 - 14, 16-25 and 30 ton Energy Recovery Wheel Filters

| Feature 1A | Quantity / Size | Type |
|---|--|-----------------|
| F, G, H, J, Q, R, S, T, U, V, W, Y, Z, 1, 2, 3 | (Prior to August 2014) 3 / 20" x 25" x 4" | Pleated, MERV 8 |
| | (Prior to August 2014) With Energy Recovery Wheel Exhaust Air Filters, Feature 6A - D, F, G, H OA - 3 / 20" x 25" x 2" EA - 6 / 14" x 20" x 2" | |
| | (After August 2014) With V-Bank Outside Air Filters OA - 6 / 20" x 16" x 2" | |
| | (After August 2014) With Energy Recovery Wheel Exhaust Air Filters, Feature 6A - D, F, G, H OA - 6 / 20" x 16" x 2" EA - 3 / 14" x 20" x 2" - 3 / 12" x 20" x 2" | |

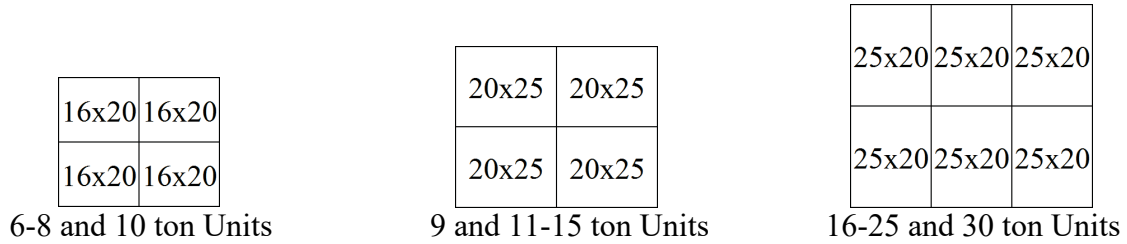

Figure 46 - RN Series 6-30 ton Standard Filter Layouts

*All dimensions are in inches and are height x length.
Layouts are viewed from the upstream side of the cooling coil.*

Filter Conversion Table

| Inches | Centimeters |
|------------------|----------------------|
| [12 x 24 x 2] | [30.5 x 61 x 5.1] |
| [12 x 24 x 4] | [30.5 x 61 x 10.2] |
| [16 x 20 x 1] | [40.6 x 50.8 x 2.5] |
| [16 x 20 x 2] | [40.6 x 50.8 x 5.1] |
| [16 x 20 x 4] | [40.6 x 50.8 x 10.2] |
| [20 x 20 x 2] | [50.8 x 50.8 x 5.1] |
| [20 x 20 x 4] | [50.8 x 50.8 x 10.2] |
| [20 x 25 x 1] | [50.8 x 63.5 x 2.5] |
| [20 x 25 x 2] | [50.8 x 63.5 x 5.1] |
| [20 x 25 x 4] | [50.8 x 63.5 x 10.2] |
| [25 x 14 x 2] | [63.5 x 35.6 x 5.1] |
| [25 x 16 x 2] | [63.5 x 40.6 x 5.1] |
| [25 x 16 x 4] | [63.5 x 40.6 x 10.2] |
| [40 x 16 x 5/16] | [101.6 x 40.6 x 0.8] |
| [47 x 12 x 5/16] | [119.4 x 30.5 x 0.8] |
| [49 x 20 x 5/16] | [124.5 x 50.8 x 0.8] |
| [55 x 16 x 5/16] | [139.7 x 40.6 x 0.8] |
| [55 x 25 x 5/16] | [139.7 x 63.5 x 0.8] |

Replacement Parts

Parts for AAON equipment may be obtained from your local AAON representative. Reference the unit serial number and part number when ordering parts.

AAON**Warranty, Service and Parts Department**

2425 S. Yukon Ave.

Tulsa, OK 74107

Ph: 918-382-6450

techsupport@aaon.com

www.aaon.com

Note: Before calling, technician must have model and serial number of the unit available for the service department to help answer questions regarding the unit.

Warranty: Refer to the Limited Warranty Certificate for the unit warranty details. Contact your AAON representative for a unit specific copy of the certificate for your serial number.



Limited Warranty Certificate

GENERAL CONDITIONS

AAON, Inc. (hereinafter referred to as "AAON") warrants this AAON equipment, as identified hereon, to be free of defects in material and workmanship under normal use, service, and maintenance. Our obligations under this warranty must be limited to repairing or replacing the defective part, or parts, which in our judgment show evidence of such defects. AAON is not liable for labor charges and other costs incurred for removing, shipping, handling or transporting defective part, or parts, or for shipping, handling, transporting, or installing repaired or replacement part, or parts.

The limited warranty is effective one (1) year from date of **original installation**, or eighteen (18) months from date of original shipment from the factory, whichever occurs first and covers all parts and components in this AAON equipment excluding air filters, belts, refrigerant moisture driers, and lost refrigerant, which are not included in any part of this limited warranty. The replacement part, or parts, assume only the unused portion of the original limited warranty and are shipped f.o.b. from the factory and freight prepaid by the factory.

The limited warranty is effective for products manufactured at the Tulsa, Oklahoma or Longview, Texas facility.

THIS LIMITED WARRANTY ONLY APPLIES WHEN THE **ORIGINAL MODEL NUMBER AND SERIAL NUMBER** OF THE AAON UNIT ARE GIVEN AT TIME OF REQUEST FOR REPLACEMENT PART, OR PARTS. DEFECTIVE PART, OR PARTS, MUST BE RETURNED **PREPAID**, WITH ITS ASSIGNED RETURN MATERIAL TAG, WITHIN FOURTEEN (14) DAYS OF RECEIPT OF THE REPLACEMENT PART, OR PARTS.

EXTENDED LIMITED WARRANTY ON COMPRESSORS INCLUDED IN SINGLE PACKAGE EQUIPMENT (NOT INCLUDING CHILLERS OR WH/WV); OPTIONAL ON OTHER EQUIPMENT

For the second through the fifth year from date of **shipment**, we further agree to repair or replace the fully hermetic compressor, at our option, for the **original purchaser-user only**. The repaired or replacement fully hermetic compressor will be supplied f.o.b. the factory, freight **prepaid and add**, providing the defective fully hermetic compressor is returned **prepaid by the customer**, and is proven to be inoperative due to defects in materials or workmanship. This extended limited warranty covers **only** the fully hermetic compressor and **does not include** any labor charges, or other additional costs incurred for removing, shipping, handling, transporting, or replacing the defective fully hermetic compressor. It also **does not include** additional costs incurred for shipping, handling, or transporting of electric controls such as relays, capacitors, pressure controls, or fan-motor assemblies, condensers, receivers, etc, which carry the standard **one-year limited warranty**.

EXTENDED LIMITED WARRANTY OF WH/WV PRODUCTS

The WH/WV limited warranty is effective five (5) years from date of original installation. If installation date cannot be verified, limited warranty is effective five (5) years from date of equipment manufacture at the factory. Warranty covers all parts and components, including compressors, in this AAON equipment except those excluded in the general conditions.

EXTENDED LIMITED WARRANTY OF RQ PRODUCTS

The RQ limited warranty is effective two (2) years from date of original **shipment** from the factory and covers all parts and components in this AAON equipment except those excluded in the general conditions.

FOR OPTIONAL TWO YEAR EXTENDED LIMITED WARRANTY OF RN PRODUCTS

The limited warranty is effective two (2) years from date of original **shipment** from the factory and covers all parts and components in this AAON equipment except those excluded in the general conditions.

FOR OPTIONAL FIVE YEAR EXTENDED LIMITED WARRANTY OF RN OR RQ PRODUCTS

The limited warranty is effective five (5) years from date of original **shipment** from the factory and covers all parts and components in this AAON equipment except those excluded in the general conditions.

FOR OPTIONAL TEN YEAR EXTENDED LIMITED WARRANTY OF RN OR RQ PRODUCTS

The limited warranty is effective ten (10) years from date of original **shipment** from the factory and covers all parts and components in this AAON equipment except those excluded in the general conditions.

FOR OPTIONAL FIVE YEAR EXTENDED LIMITED WARRANTY OF RN OR RQ ECONOMIZER WITH FAULT DETECTION AND DIAGNOSTICS

For the second through fifth year from date of shipment, we further warrant the economizer damper assembly against failure due to defects in materials and workmanship for the original purchaser-user only.

EXTENDED LIMITED WARRANTY OF GAS FIRED HEAT EXCHANGERS

FOR RQ OR RN ALUMINIZED STEEL HEAT EXCHANGERS

For the second through the fifteenth year from date of **shipment**, we further warrant the steel heat exchanger against failure due to defects in materials and workmanship for the **original purchaser-user only**.

FOR RQ, RN, OR RZ STAINLESS STEEL HEAT EXCHANGERS

For the second through the twenty-fifth year from date of **shipment**, we further warrant the stainless steel heat exchanger against failure due to defects in materials and workmanship for the **original purchaser-user only**.

FOR RL SERIES HEAT EXCHANGERS

For the second through the tenth year from date of original installation, we further warrant the steel heat exchanger against failure due to defects in materials and workmanship for the original purchaser-user only, in accordance with the following: For the first five (5) years from date of shipment, we agree to repair or replace the heat exchanger, at our option, for the original purchaser-user only; during the sixth year, we will charge 50% of the current trade price for repaired or replacement steel heat exchanger, as the case may be, during the seventh year, 60%, during the eighth year, 70% during the ninth year, 80% and during the tenth year, 90%.

In all cases, the repaired or replacement heat exchanger will be supplied f.o.b. our factory, freight prepaid, providing the defective heat exchanger is returned **prepaid**, and if it is proved to be inoperative due to defects in materials and workmanship. This extended limited warranty covers **only** the heat exchanger and **does not include** labor charges, or other costs incurred for removing, shipping, handling, transporting, or installing repaired replacement heat exchanger. This extend limited warranty **does not apply** where the furnace has been operated in an atmosphere contaminated by chlorine, fluorine, or any other damaging chemical compounds.

FOR OPTIONAL FIVE YEAR EXTENDED LIMITED WARRANTY OF COIL COATING

For the second through fifth year from date of shipment, we further warrant the coating of e-coated coils on the equipment against failure due to defects in materials and workmanship for the original purchaser-user only. Coil cleaning, maintenance, and record keeping must be followed according to the unit Installation, Operation and Maintenance Manual to maintain warranty.



Limited Warranty Certificate

OTHER CONDITIONS

This warranty **does not cover** any AAON unit or part thereof which has been subject to accident, negligence, damages in transit, misuse or abuse, or which has been tampered with or altered in any way, or which has not been installed, operated, serviced and maintained in accordance with our instructions, or which has been installed outside of the Continental United States or Canada, or on which the serial number or identification number has been altered, defaced, or removed. AAON will not be responsible for failure of the unit to start due to voltage conditions, blown fuses, open circuit breakers, or other damages due to the inadequacy or interruption of electric service.

This warranty **does not cover** equipment containing a water-to-refrigerant heat exchanger for any damage resulting from freezing, fouling, corrosion or clogging.

AAON must not be liable for any default or delay in performance hereunder, caused by a contingency beyond its control, including governmental restrictions or restraint, strikes, short or reduced supply of raw materials or parts, floods, winds, fire, lightning strikes, or any other acts of God.

DISCLAIMERS OF WARRANTIES

THIS WARRANTY IS EXCLUSIVE AND IS IN LIEU OF ANY WARRANTY OF MERCHANTABILITY, FITNESS FOR A PARTICULAR PURPOSE OR OTHER WARRANTY OF QUALITY, WHETHER EXPRESS OR IMPLIED, EXCEPT OF TITLE AND AGAINST PATENT INFRINGEMENT. CORRECTION OF NON-CONFORMITIES ARE LIMITED TO REPAIR OR REPLACEMENT OF THE DEFECTIVE PART OR PARTS, AT SELLER'S OPTION, WHICH MUST CONSTITUTE FULFILLMENT OF ALL TORT OR OTHERWISE IT IS EXPRESSLY UNDERSTOOD THAT AAON MUST NOT BE LIABLE FOR ANY CONSEQUENTIAL OR INCIDENTAL DAMAGES. AAON MUST NOT UNDER ANY CIRCUMSTANCES BE LIABLE FOR SPECIAL, INCIDENTAL OR CONSEQUENTIAL DAMAGES, SUCH AS, BUT NOT LIMITED TO DAMAGES OR LOSS OF OTHER PROPERTY OR EQUIPMENT, LOSS OF PROFITS OR REVENUE, COST OF CAPITAL, COST OF PURCHASED OR REPLACEMENT GOODS, OR CLAIMS OF BUYER OR USER FOR SERVICE INTERRUPTIONS. THE REMEDIES OF THE BUYER SET FORTH HEREIN ARE EXCLUSIVE, AND THE LIABILITY OF AAON WITH RESPECT TO ANY CONTRACT, OR ANYTHING DONE IN CONNECTION THEREWITH SUCH AS THE PERFORMANCE OR BREACH THEREFORE, OR FROM THE MANUFACTURE, SALE, DELIVERY, RESALE, INSTALLATION, OR USE OF ANY GOODS COVERED BY OR FURNISHED UNDER THIS CONTRACT WHETHER ARISING OUT OF CONTRACT, NEGLIGENCE, STRICT TORT, OR UNDER ANY WARRANTY, OR OTHERWISE, MUST NOT EXCEPT AS EXPRESSLY PROVIDED HEREIN, EXCEED THE PRICE OF THE GOODS UPON WHICH SUCH LIABILITY IS BASED.

WITH RESPECT TO THE GOODS SOLD, THE BUYER HEREBY WAIVES ALL LIABILITY ARISING FROM STATUTE, LAW, STRICT LIABILITY IN TORT, OR OTHERWISE, INCLUDING WITHOUT LIMITATION ANY OBLIGATION OF AAON WITH RESPECT TO CONSEQUENTIAL OR INCIDENTAL DAMAGES AND WHETHER OR NOT OCCASIONED BY AAON NEGLIGENCE. TIME LIMIT ON COMMENCING LEGAL ACTIONS: AN ACTION FOR BREACH OF THIS CONTRACT FOR GOOD SOLD OR ANY OTHER ACTION OTHERWISE ARISING OUT OF THIS CONTRACT, MUST BE COMMENCED WITHIN ONE (1) YEAR FROM THE DATE, THE RIGHT, CLAIM, DEMAND OR CAUSE OF ACTION MUST FIRST OCCUR, OR BE BARRED FOREVER.

SEVERABILITY

IF ANY PROVISION OR CAUSE OF THIS CONTRACT OR APPLICATION THEREOF TO ANY PERSON OR CIRCUMSTANCES IS HELD INVALID OR UNCONSCIONABLE SUCH INVALIDITY OR UNCONSCIONABILITY MUST NOT AFFECT OTHER PROVISIONS OR APPLICATIONS OF THE CONTRACT WHICH CAN BE GIVEN EFFECT WITHOUT THE INVALID OR UNCONSCIONABLE PROVISIONS OF THE CONTRACT ARE DECLARED BE SEVERABLE.

EQUIPMENT INFORMATION (REQUIRED)

Job Name: Click or tap here to

Sales Order Number: Click or tap here to enter text.

Unit Tag: Click or tap here to enter text

Date of Shipment: Click or tap here to enter text.

Serial Number: Click or tap here to enter text.

Unit Model Number: Click or tap here to enter text.

Appendix A - Heat Exchanger Corrosion Resistance

Corrosion Resistance of Copper and Stainless Steel in Brazed Plate Heat Exchangers - Points to Measure and Check in a Water Analysis

The resistance guide provides the corrosion resistance of stainless steel type AISI 316 and pure Copper (99.9%) in water, to a number of important chemical factors. The actual corrosion is a very complex process influenced by many different factors in combination.

Explanations: + Good resistance under normal conditions

0 Corrosion problems may occur especially when more factors are valued 0

- Use is not recommended

| Water Containing | Concentration (mg/l or ppm) | Time Limits - Analyze Before | AISI 316 | SMO 254 | Copper Alloy | Nickel Alloy |
|---|-----------------------------|------------------------------|----------|---------|--------------|--------------|
| Alkalinity (HCO ₃ ⁻) | < 70 | Within 24 Hours | + | + | 0 | + |
| | 70-300 | | + | + | + | + |
| | > 300 | | + | + | 0/+ | + |
| Sulfate (SO ₄ ²⁻) | < 70 | No Limit | + | + | + | + |
| | 70-300 | | + | + | 0/- | + |
| | > 300 | | 0 | 0 | - | + |
| HCO ₃ ⁻ / SO ₄ ²⁻ | > 1.0 | No Limit | + | + | + | + |
| | < 1.0 | | + | + | 0/- | + |
| Electrical Conductivity | < 10µS/cm | No Limit | + | + | 0 | + |
| | 10-500 µS/cm | | + | + | + | + |
| | > 500 µS/cm | | + | + | 0 | + |
| pH | < 6.0 | Within 24 Hours | 0 | 0 | 0 | + |
| | 6.0-7.5 | | 0/+ | + | 0 | + |
| | 7.5-9.0 | | + | + | + | + |
| | > 9.0 | | + | + | 0 | + |
| Ammonium (NH ₄ ⁺) | < 2 | Within 24 Hours | + | + | + | + |
| | 2-20 | | + | + | 0 | + |
| | > 20 | | + | + | - | + |
| Chlorides (Cl ⁻)* | < 300 | No Limit | + | + | + | + |
| | > 300 | | 0 | + | 0/+ | + |
| Free Chlorine (Cl ₂) | < 1 | Within 5 Hours | + | + | + | + |
| | 1-5 | | + | + | 0 | + |
| | > 5 | | 0/+ | + | 0/- | + |
| Hydrogen Sulfide (H ₂ S) | < 0.05 | No Limit | + | + | + | + |
| | > 0.05 | | + | + | 0/- | + |
| Free (aggressive) Carbon Dioxide (CO ₂) | < 5 | No Limit | + | + | + | + |
| | 5-20 | | + | + | 0 | + |
| | > 20 | | + | + | - | + |

*See Chloride Content Table

| Water Containing | Concentration (mg/l or ppm) | Time Limits - Analyze Before | AISI 316 | SMO 254 | Copper Alloy | Nickel Alloy |
|----------------------------|-----------------------------|------------------------------|----------|---------|--------------|--------------|
| Total Hardness (°dH) | 4.0-8.5 | No Limit | + | + | + | + |
| Nitrate (NO ₃) | < 100 | No Limit | + | + | + | + |
| | > 100 | | + | + | 0 | + |
| Iron (Fe) | < 0.2 | No Limit | + | + | + | + |
| | > 0.2 | | + | + | 0 | + |
| Aluminum (Al) | < 0.2 | No Limit | + | + | + | + |
| | > 0.2 | | + | + | 0 | + |
| Manganese (Mn) | < 0.1 | No Limit | + | + | + | + |
| | > 0.1 | | + | + | 0 | + |

Chloride Content

| Chloride Content | Maximum Temperature | | | |
|------------------|---------------------|--------------|---------------|---------------|
| | 60°C (140°F) | 80°C (176°F) | 120°C (248°F) | 130°C (266°F) |
| = 10 ppm | SS 304 | SS 304 | SS 304 | SS 316 |
| = 25 ppm | SS 304 | SS 304 | SS 316 | SS 316 |
| = 50 ppm | SS 304 | SS 316 | SS 316 | Ti / SMO 254 |
| = 80 ppm | SS 316 | SS 316 | SS 316 | Ti / SMO 254 |
| = 150 ppm | SS 316 | SS 316 | Ti / SMO 254 | Ti / SMO 254 |
| = 300 ppm | SS 316 | Ti / SMO 254 | Ti / SMO 254 | Ti / SMO 254 |
| > 300 ppm | Ti / SMO 254 | Ti / SMO 254 | Ti / SMO 254 | Ti / SMO 254 |

Appendix B - Thermistor Temperature vs. Resistance Values

| Deg C | Deg F | Resistance (kOhms) |
|-------|-------|--------------------|
| -40 | -40 | 2889.6 |
| -35 | -31 | 2087.22 |
| -30 | -22 | 1522.20 |
| -25 | -13 | 1121.44 |
| -20 | -4 | 834.72 |
| -15 | 5 | 627.28 |
| -10 | 14 | 475.74 |
| -5 | 23 | 363.99 |
| 0 | 32 | 280.82 |
| 5 | 41 | 218.41 |
| 10 | 50 | 171.17 |
| 15 | 59 | 135.14 |
| 20 | 68 | 107.44 |
| 25 | 77 | 86.00 |
| 30 | 86 | 69.28 |
| 35 | 95 | 56.16 |
| 40 | 104 | 45.81 |
| 45 | 113 | 37.58 |
| 50 | 122 | 30.99 |
| 55 | 131 | 25.68 |
| 60 | 140 | 21.40 |
| 65 | 149 | 17.91 |

| Deg C | Deg F | Resistance (kOhms) |
|-------|-------|--------------------|
| 70 | 158 | 15.07 |
| 75 | 167 | 12.73 |
| 80 | 176 | 10.79 |
| 85 | 185 | 9.20 |
| 90 | 194 | 7.87 |
| 95 | 203 | 6.77 |
| 100 | 212 | 5.85 |
| 105 | 221 | 5.09 |
| 110 | 230 | 4.45 |
| 115 | 239 | 3.87 |
| 120 | 248 | 3.35 |
| 125 | 257 | 2.92 |
| 130 | 266 | 2.58 |
| 135 | 275 | 2.28 |
| 140 | 284 | 2.02 |
| 145 | 293 | 1.80 |
| 150 | 302 | 1.59 |
| 155 | 311 | 1.39 |
| 160 | 320 | 1.25 |
| 165 | 329 | 1.12 |
| 170 | 338 | 1.01 |
| 175 | 347 | 0.92 |
| 180 | 356 | 0.83 |

RN Series Startup Form

| | |
|---------------------------|--------------|
| Date: _____ | |
| Job Name: _____ | |
| Address: _____ | |
| Model Number: _____ | |
| Serial Number: _____ | Tag: _____ |
| Startup Contractor: _____ | |
| Address: _____ | Phone: _____ |

| Pre Startup Checklist | | |
|---|------------------------------|-----------------------------|
| Installing contractor must verify the following items. | | |
| 1. Is there any visible shipping damage? | Yes <input type="checkbox"/> | No <input type="checkbox"/> |
| 2. Is the unit level? | Yes <input type="checkbox"/> | No <input type="checkbox"/> |
| 3. Are the unit clearances adequate for service and operation? | Yes <input type="checkbox"/> | No <input type="checkbox"/> |
| 4. Do all access doors open freely and are the handles operational? | Yes <input type="checkbox"/> | No <input type="checkbox"/> |
| 5. Have all electrical connections been tested for tightness? | Yes <input type="checkbox"/> | No <input type="checkbox"/> |
| 6. Does the electrical service correspond to the unit nameplate? | Yes <input type="checkbox"/> | No <input type="checkbox"/> |
| 7. On 208/230V units, has transformer tap been checked? | Yes <input type="checkbox"/> | No <input type="checkbox"/> |
| 8. Has overcurrent protection been installed to match the unit nameplate requirement? | Yes <input type="checkbox"/> | No <input type="checkbox"/> |
| 9. Have all set screws on the fans been tightened? | Yes <input type="checkbox"/> | No <input type="checkbox"/> |
| 10. Do all fans rotate freely? | Yes <input type="checkbox"/> | No <input type="checkbox"/> |
| 11. Is all copper tubing isolated so that it does not rub? | Yes <input type="checkbox"/> | No <input type="checkbox"/> |
| 12. Has outside air rain hood been opened? | Yes <input type="checkbox"/> | No <input type="checkbox"/> |
| 13. Have the damper assemblies been inspected? | Yes <input type="checkbox"/> | No <input type="checkbox"/> |
| 14. Are the air filters installed with proper orientation? | Yes <input type="checkbox"/> | No <input type="checkbox"/> |
| 15. Have condensate drain and p-trap been connected? | Yes <input type="checkbox"/> | No <input type="checkbox"/> |

| Supply Fan Assembly | | | | |
|----------------------------|-----------------------------|--------------------|-----------------------------|----------------------|
| Alignment | | Check Rotation | | Nameplate Amps _____ |
| Number | hp <input type="checkbox"/> | L1 | <input type="checkbox"/> L2 | L3 |
| 1 | | | | |
| 2 | | | | |
| Band Size _____ | | VAV Controls _____ | | |
| VFD Frequency _____ | | | | |

| Energy Recovery Wheel Assembly | | | | |
|---|----|---|----|----------|
| Wheel(s) Spin Freely <input type="checkbox"/> | | Check Rotation <input type="checkbox"/> | | FLA_____ |
| Number | hp | L1 | L2 | L3 |
| 1 | | | | |
| 2 | | | | |

| Power Return/Exhaust Assembly | | | | |
|--------------------------------------|----|---|----|---------------------|
| Alignment <input type="checkbox"/> | | Check Rotation <input type="checkbox"/> | | Nameplate Amps_____ |
| Number | hp | L1 | L2 | L3 |
| 1 | | | | |
| 2 | | | | |

| Outside Air/Economizer Dampers |
|--|
| Operation Check <input type="checkbox"/> |
| Damper Actuator Type: |
| Economizer Changeover Type and Operations: |
| Damper Wiring Check <input type="checkbox"/> |
| Gears Check <input type="checkbox"/> |

| Ambient Temperature | |
|--|--|
| Ambient Dry Bulb Temperature_____°C/°F | Ambient Wet Bulb Temperature_____°C/°F |

| Unit Configuration | |
|---|---|
| Water-Cooled Condenser <input type="checkbox"/> | Air-Cooled Condenser <input type="checkbox"/> |
| No Water Leaks <input type="checkbox"/> | |
| Condenser Safety Check <input type="checkbox"/> | |
| Water Flow_____GPM | |
| Water Inlet Temperature_____°C/°F | |
| Water Outlet Temperature_____°C/°F | |

| Compressors / DX Cooling | | | | | | |
|---------------------------------|----|----|----|----------------------------|-------------------------------|-----------------------------|
| Number/stage | L1 | L2 | L3 | Head Pressure KPA/ PSIG | Suction Pressure KPA/ PSIG | Crankcase Heater Amps |
| 1 | | | | | | |
| 2 | | | | | | |
| 3 | | | | | | |
| 4 | | | | | | |

| Refrigeration System 1 – Cooling Mode | | | | | |
|---|----------|-----------------------|------------------|-------------|-----------|
| | Pressure | Saturated Temperature | Line Temperature | Sub-cooling | Superheat |
| Discharge | | | | N/A | N/A |
| Suction | | | | N/A | |
| Liquid | | | | | N/A |
| Refrigeration System 2 – Cooling Mode | | | | | |
| | Pressure | Saturated Temperature | Line Temperature | Sub-cooling | Superheat |
| Discharge | | | | N/A | N/A |
| Suction | | | | N/A | |
| Liquid | | | | | N/A |
| Refrigeration System 3 – Cooling Mode | | | | | |
| | Pressure | Saturated Temperature | Line Temperature | Sub-cooling | Superheat |
| Discharge | | | | N/A | N/A |
| Suction | | | | N/A | |
| Liquid | | | | | N/A |
| Refrigeration System 4 – Cooling Mode | | | | | |
| | Pressure | Saturated Temperature | Line Temperature | Sub-cooling | Superheat |
| Discharge | | | | N/A | N/A |
| Suction | | | | N/A | |
| Liquid | | | | | N/A |
| Refrigeration System 1 – Heating Mode (Heat Pump only) | | | | | |
| | Pressure | Saturated Temperature | Line Temperature | Sub-cooling | Superheat |
| Discharge | | | | N/A | N/A |
| Suction | | | | N/A | |
| Liquid | | | | | N/A |
| Refrigeration System 2 – Heating Mode (Heat Pump only) | | | | | |
| | Pressure | Saturated Temperature | Line Temperature | Sub-cooling | Superheat |
| Discharge | | | | N/A | N/A |
| Suction | | | | N/A | |
| Liquid | | | | | N/A |
| Refrigeration System 3 – Heating Mode (Heat Pump only) | | | | | |
| | Pressure | Saturated Temperature | Line Temperature | Sub-cooling | Superheat |
| Discharge | | | | N/A | N/A |
| Suction | | | | N/A | |
| Liquid | | | | | N/A |

| Refrigeration System 4 – Heating Mode (Heat Pump only) | | | | | |
|--|----------|-----------------------|------------------|-------------|-----------|
| | Pressure | Saturated Temperature | Line Temperature | Sub-cooling | Superheat |
| Discharge | | | | N/A | N/A |
| Suction | | | | N/A | |
| Liquid | | | | | N/A |

| Air-Cooled Condenser | | | | | |
|------------------------------------|----|---|----|----------------------|--|
| Alignment <input type="checkbox"/> | | Check Rotation <input type="checkbox"/> | | Nameplate Amps _____ | |
| Number | hp | L1 | L2 | L3 | |
| 1 | | | | | |
| 2 | | | | | |
| 3 | | | | | |
| 4 | | | | | |
| 5 | | | | | |
| 6 | | | | | |

| Water/Glycol System | | |
|--|------------------------------|-----------------------------|
| 1. Has the entire system been flushed and pressure checked? | Yes <input type="checkbox"/> | No <input type="checkbox"/> |
| 2. Has the entire system been filled with fluid? | Yes <input type="checkbox"/> | No <input type="checkbox"/> |
| 3. Has air been bled from the heat exchangers and piping? | Yes <input type="checkbox"/> | No <input type="checkbox"/> |
| 4. Is the glycol the proper type and concentration (N/A if water)? | Yes <input type="checkbox"/> | No <input type="checkbox"/> |
| 5. Is there a minimum load of 50% of the design load? | Yes <input type="checkbox"/> | No <input type="checkbox"/> |
| 6. Has the water piping been insulated? | Yes <input type="checkbox"/> | No <input type="checkbox"/> |
| 7. What is the freeze point of the glycol (N/A if water)? _____ | <input type="checkbox"/> | <input type="checkbox"/> |

| Gas Heating | | | |
|---|---------------------------------|---|---------------------------------|
| Natural Gas <input type="checkbox"/> | | Propane <input type="checkbox"/> | |
| Purge Air from Lines <input type="checkbox"/> | | Verify Pilot Spark <input type="checkbox"/> | |
| Stage | Manifold Pressure (mmHg [w.c.]) | Stage | Manifold Pressure (mmHg [w.c.]) |
| 1 | | 3 | |
| 2 | | 4 | |

| Electric Heating | | | |
|--|------|---|------|
| Stages _____ | | | |
| Limit Lockout <input type="checkbox"/> | | Aux. Limit Lockout <input type="checkbox"/> | |
| Stage | Amps | Stage | Amps |
| 1 | | 5 | |
| 2 | | 6 | |
| 3 | | 7 | |
| 4 | | 8 | |

| Electric Preheating | | | |
|--|------|---|------|
| Limit Lockout <input type="checkbox"/> | | Aux. Limit Lockout <input type="checkbox"/> | |
| Outside Air Temperature Setpoint _____ °C/°F | | | |
| Preheat Leaving Air Temperature Setpoint _____ °C/°F | | | |
| Stage | Amps | Stage | Amps |
| 1 | | 5 | |
| 2 | | 6 | |
| 3 | | 7 | |
| 4 | | 8 | |

Maintenance Log

This log must be kept with the unit. It is the responsibility of the owner and/or maintenance/service contractor to document any service, repair or adjustments. AAON Service and Warranty Departments are available to advise and provide phone help for proper operation and replacement parts. The responsibility for proper start-up, maintenance and servicing of the equipment falls to the owner and qualified licensed technician.

| Entry Date | Action Taken | Name/Tel. |
|-------------------|---------------------|------------------|
| | | |
| | | |
| | | |
| | | |
| | | |
| | | |
| | | |
| | | |
| | | |
| | | |
| | | |
| | | |
| | | |
| | | |
| | | |
| | | |
| | | |
| | | |
| | | |
| | | |
| | | |
| | | |

Maintenance Log (E-Coated Coil)

AAON E-COATED COIL MAINTENANCE RECORD

Installation Site _____ Installation Date _____
 Unit Model # _____ Unit Location _____
 Unit Serial # _____ Customer _____

| Year 20____ | Ambient Temp (°F) | Surface Debris Removed | Coil Cleaned | Approved Cleaner Used | Potable Water Backwash Rinse | Potable Water Frontwash Rinse | Chlorides Removed | Comments |
|----------------|-------------------------|---------------------------|-----------------|--------------------------|---------------------------------|----------------------------------|----------------------|----------|
| Jan | | | | | | | | |
| Feb | | | | | | | | |
| Mar | | | | | | | | |
| Apr | | | | | | | | |
| May | | | | | | | | |
| Jun | | | | | | | | |
| Jul | | | | | | | | |
| Aug | | | | | | | | |
| Sep | | | | | | | | |
| Oct | | | | | | | | |
| Nov | | | | | | | | |
| Dec | | | | | | | | |

The following cleaning agents have been approved for use on AAON E-Coated Coils to remove mold, mildew, dust, soot, greasy residue, lint and similar particulate without harming the coated surfaces.

| CLEANING AGENT | RESELLER | PART NUMBER | RECOMMENDED CHLORIDE REMOVER |
|--|---|---------------------------------|--|
| GulfClean™ Coil Cleaner or Enviro-Coil Cleaner | Rectorseal 2601 Spenwick Drive, Houston, Texas 77055 (P): 713-263-8001 | G074480 / 80406 or V82540 | Rectorseal 2601 Spenwick Drive, Houston, Texas 77055 (P): 713-263-8001 |
| GulfClean Salt Reducer™ | " " | G074490 / 80408 | |

Literature Change History

January 2022

Added some circuit breakers sizes to Feature 10 Power Options. Added Outside Airflow Monitoring Size D option to Feature 14A and changed the title from Preheat Configuration to Outside Air Configuration. Added 65 kAIC to Feature 18 Electrical Rating. Changed the LEAK CHECK GAS PIPE Danger wording from must to shall. Updated the OA filters in the Energy Recovery Wheel Filters table for when F1A = 4.

August 2022

Added zero degree cold climate air-source heat pump feature in Model option A2. Added field adjustable glycol % with aluminum recovery wheel in Feature 15.

March 2023

Updated gas heat section to include updated table for piping connections and information pertaining to new manifold design. Included sample document for limited warranty certificate.

August 2023

Added UL-60335 information to text, warnings, and table. Provide metric conversions for Imperial units in the document. Updated feature string F13 to add “Gas piped to the valve” statement. New IOM part number to identify with gas heating change and UL Standard information.

September 2023

Finalized formatting before printing new IOMs

April 2024

Removed information pertaining to units over 30 tons since this manual only applies to 6 – 30 tons.



AAON
2425 South Yukon Ave.
Tulsa, OK 74107-2728
www.AAON.com

RN Series
Installation, Operation &
Maintenance
V02940 · Rev. A · 240610

Factory Technical Support: (918) 382-6450

Note: Before calling Technical Support, please have the model and serial number of the unit available.

Parts: For replacement parts, please contact your local AAON Representative.

It is the intent of AAON to provide accurate and current product information. However, in the interest of product improvement, AAON reserves the right to change pricing, specifications, and/or design of its product without notice, obligation, or liability.