

AAON[®]

RK SERIES HEATING • COOLING & COMBINATION ROOFTOP UNITS



INSTALLATION INSTRUCTION MANUAL



update 7-2000



WARNING

If the information in this manual is not followed exactly, a fire or explosion may result causing property damage, personal injury or loss of life.

FOR YOUR SAFETY

DO NOT STORE OR USE GASOLINE OR OTHER FLAMMABLE VAPORS AND LIQUIDS IN THE VICINITY OF THIS OR ANY OTHER APPLIANCE.

FOR YOUR SAFETY

WHAT TO DO IF YOU SMELL GAS

- EXTINGUISH ANY OPEN FLAME.
- DO NOT TOUCH ANY ELECTRICAL SWITCH.
- DO NOT TRY TO LIGHT ANY APPLIANCE.
- DO NOT USE ANY PHONE IN YOUR BUILDING.
- IMMEDIATELY CALL YOUR GAS SUPPLIER FROM A NEIGHBOR'S PHONE.
FOLLOW THE GAS SUPPLIER'S INSTRUCTIONS.
- IF YOU CANNOT REACH YOUR GAS SUPPLIER,
CALL THE FIRE DEPARTMENT.

TABLE OF CONTENTS

SECTION	PAGE NUMBER
GENERAL DESCRIPTION	03
Unpacking	
Certification	
Codes and Ordinances	
OWNER'S INFORMATION	04
HEATING / COOLING SYSTEMS	05
INSTALLATION	06
Setting the Curb / Unit	07
Outside Air Hood	08
Electrical Info	
Gas Piping Info	09
Service Clearances	
Condensate Piping Info	10
GAS UNIT LIGHTING INSTRUCTIONS	11
PERIODIC INSPECTION PROCEDURES	12
Gas Heating, Cooling, Electric, Steam, Hot Water & Chilled Water Units	
SERVICE, TROUBLE SHOOTING & MAINTENANCE	14
Lubrication	
Cleaning	
FILTER INSTALLATION / REPLACEMENT	15
SERVICING	16
Rooftop Unit Replacement Parts	18
SEQUENCE OF OPERATIONS	19
Heating	
Cooling	
Optional Economizer	
VAV Systems	20
Power Exhaust Options	
COMPRESSOR CHECKOUT PROCEDURE	21
IGNITION CONTROL CHECKOUT PROCEDURE	22
FACTORY START-UP FORM	23

Owner should pay particular attention to the words: **NOTE, CAUTION AND WARNING**. **NOTES** are intended to clarify or make the installation easier. **CAUTIONS** are given to prevent equipment damage. **WARNINGS** are given to alert owner that personal injury and/or equipment damage may result if installation procedure is not handled properly.

It is the intent of AAON, Inc. to provide accurate and current specification information. However, in the interest of product improvement, AAON, Inc. reserves the right to change pricing, specifications and/or design of its products without notice, obligation or liability.

© 2000 AAON, Inc., all rights reserved throughout the world.
 AAON & AAONAIRES are registered trademarks of AAON, Inc., Tulsa, OK.

GENERAL DESCRIPTION

The units are designed as self-contained heating, cooling or combination units for outdoor installation only, using the refrigerant shown on the rating plate, chilled water, natural or propane gas, electric resistance, steam or hot water.

UNPACKING

When received, the unit should be checked for damage that might have occurred in transit. If damage is found, it should be noted on the carrier's Freight Bill. A request for inspection by carrier's agent should be made in writing at once.

CERTIFICATION

• GAS HEAT MODELS

- (a) Design Certified as a forced air furnace with or without cooling unit.
- (b) Certified for outdoor installation only.
- (c) Certified for installation on combustible roof with a minimum of 12" high curb.
- (d) Certified with Heat Exchanger located downstream from Evaporator coil.

• STEAM OR HOT WATER HEAT MODELS

- (a) Certified as a forced air furnace with or without cooling unit.
- (b) Certified for outdoor installation only.
- (c) Certified for installation on combustible roof with a minimum of 12" high curb.
- (d) ARI certified coils.

• ELECTRIC HEAT MODELS

- (a) Certified as an electric warm air furnace with or without cooling unit.
- (b) Certified for outdoor installation only.
- (c) Certified for installation on combustible roof with a minimum of 12" high curb.

• COOLING MODELS

- (a) Certified as a commercial central air-conditioner with or without electrically operated compressor.
- (b) Certified for outdoor installation only.
- (c) Certified for installation on combustible roof with a minimum of 12" high curb.
- (d) ARI certified coils.

CODES AND ORDINANCES

System should be sized in accordance with National Warm Air Heating and Air Conditioning Association Literature, or the Guide of American Society of Heating, Refrigeration and Air Conditioning Engineers. The installation must conform with local building codes or, in the absence of local codes with (United States) National Fuel Gas Code "ANSI-Z223.1", (Canada) current CAN / CGA- B149.1 or . 2. Installation Codes for Gas Burning Appliances and Equipment, current C.S.A. Standard C22.1, Canadian Electrical Code Part 1, and C.S.A. Standard B52 Mechanical Refrigeration Code, and Local Plumbing or Waste Water Codes.



WARNING

Improper installation, adjustment, alteration, service or maintenance can cause property damage, personal injury or loss of life. Installation and service must be performed by a qualified installer, service agency or the gas supplier.

*NOTE: These units **must not** be used as a "construction heater" at any time during any phase of construction. Very low return air temperatures, harmful vapors, and misplacement of the filters will damage the unit and its efficiency.*



IMPORTANT

The Clean Air Act of 1990 bans the intentional venting of refrigerant (CFC's and HCFC's) as of July 1, 1992. Approved methods of recovery, recycling or reclaiming must be followed. Fines and/or incarceration may be levied for non-compliance.

OWNER'S INFORMATION

WARNING

Failure to observe the following instructions will result in premature failure of your system, and possible voiding of the warranty.

DIRECT EXPANSION (DX) COOLING UNITS

Never cut off the main power supply to the unit, except for complete shutdown. When power is cut off from the unit, any compressors using crankcase heaters cannot prevent refrigerant migration. This means the compressor will cool down, and liquid refrigerant will accumulate in the compressor. Since the compressor is designed to pump refrigerant gas, damage may occur when power is restored.

If power must be cut off for more than an hour, turn the thermostat system switch to "OFF", and leave it off until the main power switch has been turned on again for at least twenty four hours for units with compressor crankcase heaters. This will give the crankcase heater time to clear any liquid accumulation out of the compressor before it is required to run.

Always control the system from the thermostat, or control panel, never at the main power supply (except for emergency or for complete shutdown of the system).

During the cooling season, if the air flow is reduced due to dirty air filters or any other reason, the cooling coils will get too cold and will cause excessive liquid to return to the compressor. As the liquid concentration builds up, oil is washed out of the compressor, leaving it starved for lubrication.

THE COMPRESSOR LIFE WILL BE SERIOUSLY SHORTENED BY THIS REDUCED LUBRICATION, AND THE PUMPING OF EXCESSIVE AMOUNTS OF LIQUID OIL AND REFRIGERANT.

GAS OR ELECTRIC HEATING

The system is designed to cool or heat a given amount of air each minute it operates. If this amount of air is greatly reduced (approximately 1/3 during the heating season), the heat exchanger / heater coil will overheat, and may cut the burner / heater off entirely by action of the safety high temperature limit device which is incorporated in the exchanger or heating area.

GAS HEAT UNITS - Should overheating occur, or the gas supply fail to shut off; shut off the manual gas valve to the furnace before shutting off the electrical supply.

PROLONGED OVERHEATING OF THE HEAT EXCHANGER WILL SHORTEN ITS LIFE.

Improper installation, adjustment, alteration, service or maintenance can cause property damage, personal injury or loss of life. Installation and service must be performed by a qualified installer, service agency or if gas fired units, the gas supplier. Refer to installation instructions provided with the unit and this manual.

CAUTION: While the following incorrect operations may not cause damage to the system, they will impair the performance, and may cause the built-in safety devices to cut the system off completely.

1. LOW AMBIENT OPERATION

The cooling section of a direct expansion (DX) unit will not operate properly when the outdoor temperature is below 55° degrees. Outside air intake options are recommended if operation below 55° degrees is expected.

2. MULTIPLE UNIT OPERATION

When several units are used in conditioning the space, and part or all of them are combination heating-cooling units, all systems thermostat switches must be set at either heating or cooling (or set at "off"). Do not leave part of the systems switched to the opposite mode. All cooling only units should be switched to "off" at the thermostat during the heating season.

WIRING DIAGRAMS

A complete set of unit specific wiring diagrams in both ladder and point-to-point form are laminated in plastic and located inside the control compartment door.

CONDENSATE PIPING

The unit requires a drain trap to be connected to the drainpan at the unit. If codes require a condensate drain line, the line should be the same pipe size as the drain nipple and should pitch downward toward drain.

The condensate drain pipe ("P" trap) is factory supplied and is shipped loose in the control access compartment for field installation. An air break should be used with long runs of condensate lines.



WARNING

Scroll compressors will be damaged by operation with the wrong rotation. THE LOW PRESSURE SWITCH HAS BEEN DISCONNECTED AFTER TESTING AT THE FACTORY.

The wiring must be reconnected and proper rotation determined at the time of start-up by a qualified service technician using suction and discharge pressures gauges. Any alteration should only be made at the unit power connection.

HEATING & COOLING SYSTEMS

NORMAL OPERATION

HEATING

Set the thermostat system switch to "HEAT".
Set the thermostat fan switch to "AUTO" or "ON".
Set the thermostat temperature at the desired point.

COOLING

Set the thermostat system switch to "COOL".
Set the thermostat fan switch to "AUTO" or "ON".
Set the thermostat temperature at the desired point.

AIR CIRCULATION

Set the thermostat system switch to "OFF".
Set the thermostat fan switch to "ON".
Do not change temperature setting.
With these settings, the air circulating blower will run continuously but the air will not be heated or cooled.

SYSTEM OFF

Set the thermostat system switch to "OFF".
Set the thermostat fan switch to "AUTO".
Do not change temperature setting.
With these settings, the system is shut down, with the exception of the control system power (24 volts), and the crankcase heater of the compressor (about 60 watts).

DO NOT TURN OFF THE MAIN POWER SWITCH.

NIGHT AND VACANT WEEKEND OPERATION

If it is desired to reduce the operating time during the night, and during periods when the space is unused, it is recommended that the temperature setting be raised about five degrees during these periods of the cooling season, and lowered about ten degrees during the heating season.

GAS HEATING SYSTEM

The heating section is for use with natural gas supply pressure of 6" to 10.5" Water Column. The unit can also be fired on propane gas with a supply pressure to the valve of 11" to 12" Water Column. A 1/8" pressure tap must be supplied by the installer in the piping just ahead of the gas valve. The rating plate on the furnace shall be inspected to make sure that the unit is stamped for the proper gas. The pressure tap on the outlet end of the gas valve should be removed and the valve adjusted for the proper manifold pressure to 3.5" on natural gas and 10.5" for propane gas.

The burner area is not sealed and combustion air is supplied by a centrifugal blower which draws in fresh air through a protected opening. This air is introduced into the burner tubes by the action of the induced draft blower. This insures an even flow of primary and secondary air to the burners.

The heating system and safety controls are 100% tested on each unit before it leaves the factory.

INSTALLATION IS TO BE ADJUSTED TO OBTAIN AN AIR TEMPERATURE RISE WITHIN THE RANGE SPECIFIED ON THE RATING PLATE.

The units are equipped with a direct spark ignition system which proves the burner operation during each call for heat.

Power to the ignition control is 24 volts to reduce hazards. Burner ignition is by a high intensity spark. When heat is called for, the cooling system is inoperable except for the indoor blower motor. Actual heating is accomplished by firing gas into the heat exchanger assembly.

ELECTRIC HEATING SYSTEM

Heating is accomplished by passing electrical current through a specified amount of resistance heaters which will produce the required heat. The indoor blower motor will energize at the same time as the heaters.

STEAM OR HOT WATER HEATING SYSTEM

Heating is accomplished by passing steam or hot water through the steam or hot water coil assembly.

COOLING SECTION • DX

All direct expansion refrigeration systems are factory assembled, charged with refrigerant, tested and operated. On all units 8 ton and larger the refrigerant system includes multiple circuit evaporator and condenser coils providing two or more stages of cooling. These systems are provided with liquid line filter driers, expansion valves and fully hermetic compressors. Compressors are equipped with a positive pressure forced lubrication system. The air cooled condenser coil(s) is constructed of copper tubes with aluminum fins, the air is pulled through with propeller fans. The evaporator coil is draw through, made of copper tubes with aluminum fins.

The refrigeration section of these appliances has been found acceptable with applicable provisions of "ANSI / UL 1995" and current "C.S.A. Standard C22.2" by E.T.L.

NOTE: Crankcase Heater Operation

Some units are equipped with a compressor crankcase heater, which should be energized at least 24 hours prior to setting the thermostat for cooling operation.

COOLING SECTION • CHILLED WATER or NON-COMPRESSORIZED UNIT

Chilled water or non-compressorized units have factory installed coils. These systems are provided with internal header connections for field connection. Coils are aluminum fin / copper tube construction.

INSTALLATION



CAUTION

If outside air is in contact with the bottom of the unit, the unit must have the bottom insulation option or be field insulated.

DO NOT DRILL OR PUNCH HOLES IN BASE OF UNIT FROM INSIDE THE UNIT OR FROM BELOW TO ATTACH DUCTWORK. LEAKING MAY OCCUR IF UNIT BASE IS PUNCTURED.

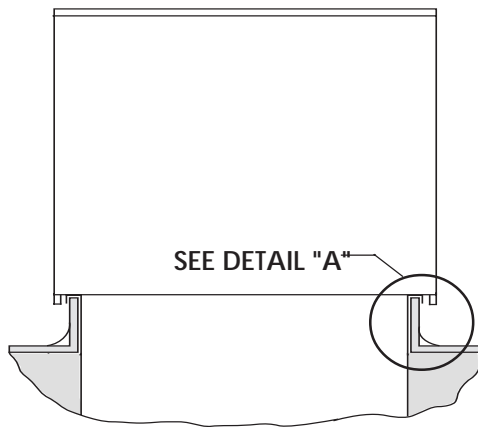

SEE DETAIL "A"

SECTIONAL VIEW OF UNIT ON ROOF CURB



WARNING

INSULATION MATERIALS MAY BE COMBUSTIBLE

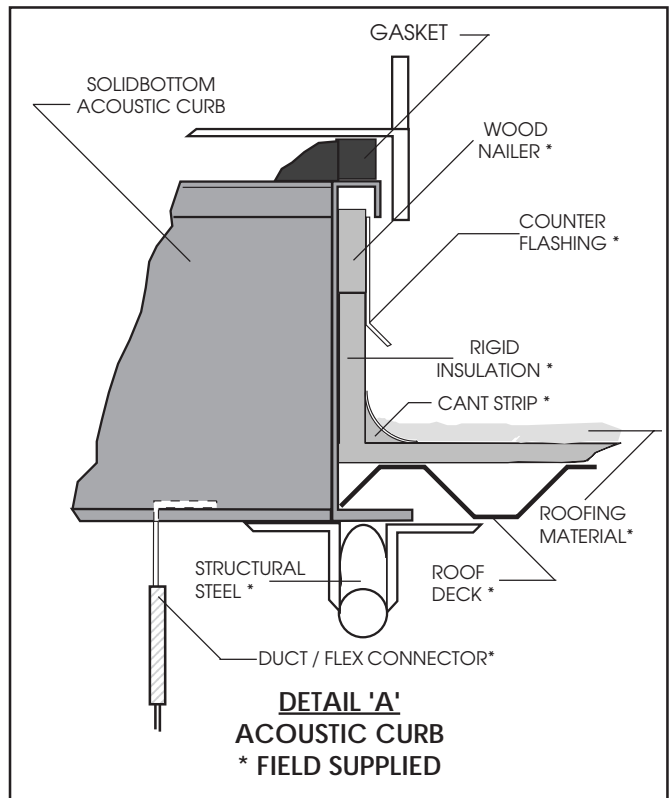
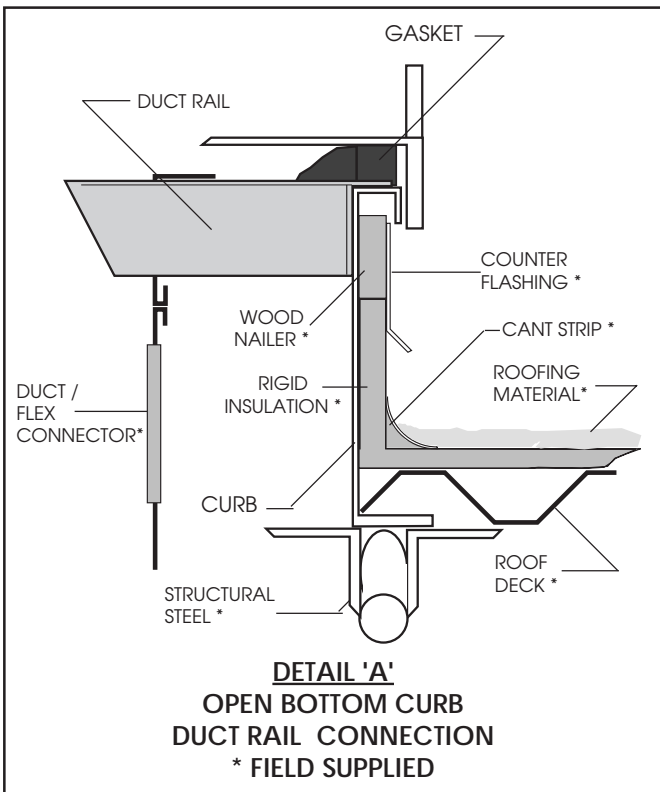
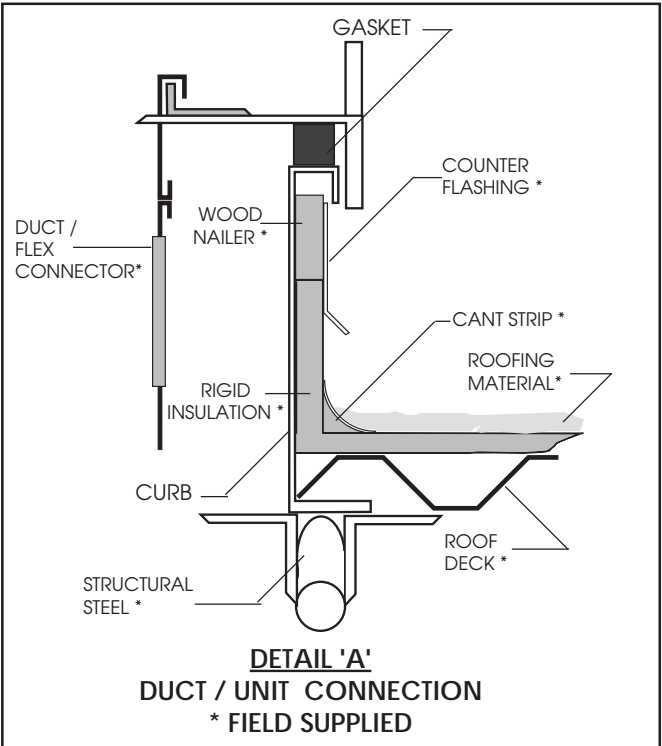

INSTALLATION continued

AAON Rooftop units are designed for fast, easy installation. The curb is mounted first and must be located so that duct connections will be clear of structural members of the building.

SETTING THE CURB

When using the factory curb, make openings in roof decking large enough to allow for duct penetrations and workspace only. Do not make openings larger than necessary. Set the curb to coincide with the openings. Make sure the curb is level.

SETTING THE UNIT

If cables or chains are used to hoist the unit they must be the same length and care should be taken to prevent damage to the cabinet / coils or condenser fans. It is recommended lifting the unit with the outside air hood in the downward shipping position, however the unit may be lifted with the outside air hood in the open position.

Before lifting unit, be sure that all shipping material has been removed from unit. Secure hooks and cables at all lifting points / lugs provided on the unit.

Hoist unit to a point directly above the curb and duct openings. Lower unit while guiding the unit to align with utility opening and duct openings. Be sure that the gasket material has been applied to curb. Continue lowering the unit until the unit skirt fits around the curb. Make sure the unit is properly seated on the curb and is level.

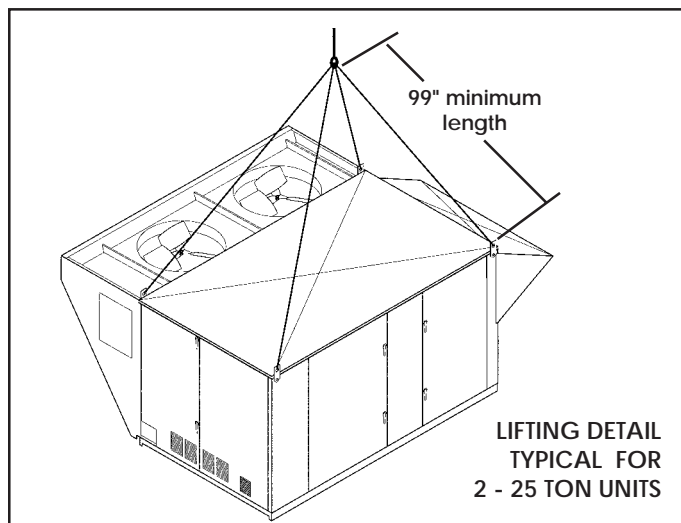
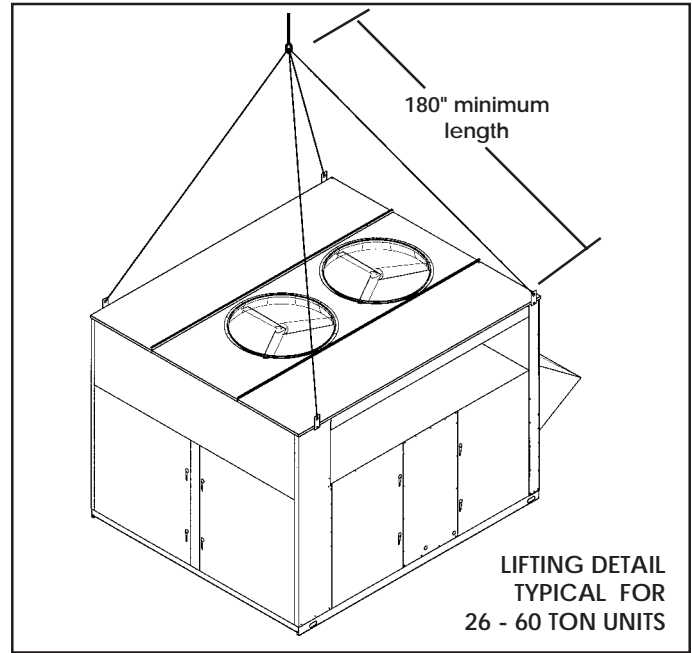

The unit shall be installed so that the rectangular flue (if applicable) is located at least 120" away from any opening through which combustion products could enter the building. The unit shall also be installed so that the flow of combustion and ventilating air is not obstructed from reaching the furnace. Do not position flue opening to discharge into a fresh air intake of any other piece of equipment.

! WARNING

Improper installation, adjustment, alteration, service or maintenance can cause property damage, personal injury or loss of life. Installation and service must be performed by a qualified installer, service agency or the gas supplier.

Install the gas fired unit to assure the flow of combustion and ventilating air is not obstructed from reaching the heater and that the flue outlet is located at least 120 inches away from any opening through which combustion products could enter the building.

! CAUTION

Where the supply or warm air duct passes through a combustible roof, a clearance of one inch must be maintained between the outside edges of the duct and combustible material in accordance with National Fire Protection Association Standard No. 90A. Provide flashings or enclosure between structure and roof and all joints must be sealed with mastic roofing to ensure a watertight seal.

All roofing work should be performed by competent roofing contractors to avoid any possible leakage.

INSTALLATION continued

OUTSIDE AIR HOOD

For proper unit operation, the air hood must be opened at start-up as shown below:

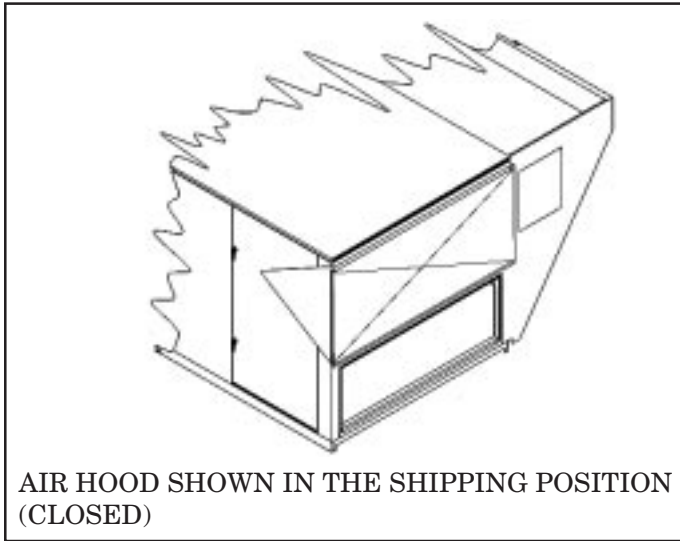

Remove shipping screws from each side of the hood in the "closed" position. Lift hood to the "open" position, seal flange and secure with sheet metal screws.

Air hoods may vary according to unit size and options. The illustration shown is for practical guidelines for all outside air hoods.

Outdoor air intake adjustments should be made according to building ventilation or local code requirements.

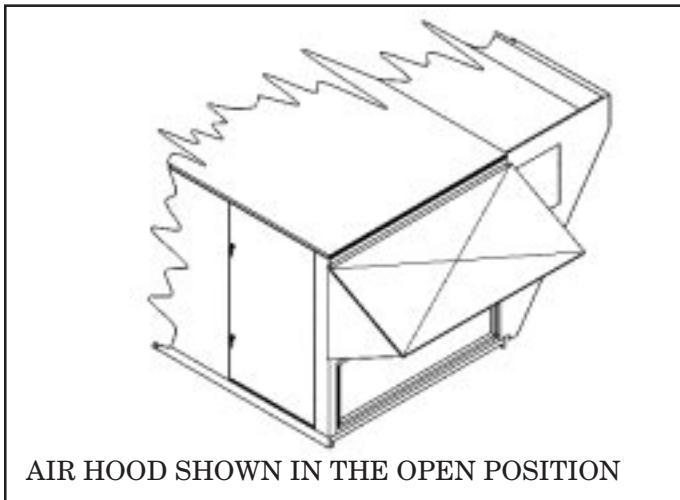

WARNING

Electric shock hazard. Can cause injury or death. Before attempting to perform any service or maintenance, turn the electrical power to unit to OFF at disconnect switch(es). Unit may have multiple power supplies.

ELECTRICAL

Check the unit data plate voltage to make sure it agrees with the power supply. Connect power to the unit according to the wiring diagram provided with the unit.

The power and control wiring may be brought up through the utility entry. Protect the branch circuit in accordance with code requirements. Control wires should not be run inside the same conduit. The unit must be electrically grounded in accordance with the current National Electric Code, ANSI/NFPA No. 70. In Canada use current C.S.A. Standard C22.1 Canadian Electric Code Part 1.

Power wiring is to the unit terminal block or main disconnect. All wiring beyond this point has been done by the manufacturer and cannot be modified without effecting the unit's agency / safety certification.

AIRFLOW IS TO BE ADJUSTED AFTER INSTALLATION TO OBTAIN AN AIR TEMPERATURE RISE WITHIN THE RANGE SPECIFIED ON THE RATING PLATE.

DUE TO JOB SPECIFICATION REVISIONS, IT MAY BE NECESSARY TO ADJUST OR CHANGE THE SHEAVE OR PULLEY TO OBTAIN THE DESIRED AIRFLOW AT THE TIME OF INSTALLATION.

START-UP TECHNICIAN MUST CHECK BLOWER MOTOR AMPERAGE TO ENSURE THAT THE AMPERAGE LISTED ON THE MOTOR NAMEPLATE IS NOT EXCEEDED.

NOTE: All units are factory wired for 208 / 230, 460 or 575 volt. If unit is to be connected to a 208v supply, the transformer must be rewired for 208v service. For 208v service interchange the yellow and red conductor on the low voltage control transformer.

RED - BLK 208 volt ;
YEL - BLK 230 volt.

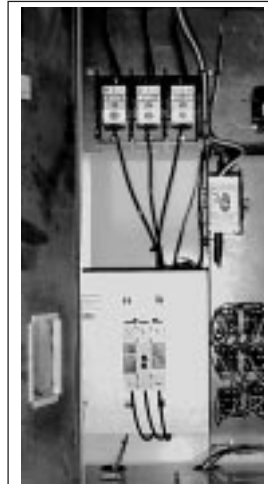

CAUTION

On three phase units the rotation must be checked on ALL MOTORS AND COMPRESSORS. SCROLL COMPRESSORS ARE DIRECTIONAL.

Rotation must be checked on start-up by a qualified service technician using suction and discharge gauges.

Scroll compressors will FAIL if run in the wrong direction. Blower and condenser rotation should be checked and only be altered if necessary at the power connection.

SERVICE CLEARANCES

LOCATION	UNIT SIZE			
	2 - 7	8 - 15	16 - 25	26 - 60
Return Air (Back)	36"	48"	48"	60"
Vent Side (Front)	48"	48"	48"	48"
Left Side	6"	6"	6"	60"
Right Side	48"	60"	60"	60"
Top	UNOBSTRUCTED			

GAS PIPING

Size gas piping to supply the unit with 6" to 10.5" water column pressure for natural gas or 11" water column pressure for propane when all gas consuming devices in the building connected to the same gas system are operating. Install piping in accordance with local codes, the piping must conform with the latest ANSI-Z223.1 National Fuel Gas Code; in Canada, Current Standard CAN / CGA-B149, Installation Codes for Gas Burning Appliances and Equipment.

Some utility companies will require pipe sizes larger than the minimum sizes listed.

GAS PIPING SIZES

UNIT SIZE / TONS	INPUT / MBH	PIPE SIZE
02 - 03	69	3/4"
04	90	3/4"
05 - 06 - 07	90 - 180	3/4"
08 - 10	180 - 270 - 351	3/4"
13 - 15	180 - 270 - 390	3/4"
16 - 20 - 25	270 - 390 - 480	3/4"
26 - 30 - 40 - 50 - 60	540 - 780	(2) 3/4"

NOTE: Codes may require the use of a manual main gas shut-off valve and union, (furnished by others) installed in the gas line external to the unit.

GAS PIPING is to be supported **DIRECTLY AT CONNECTION TO UNIT** and must not be strained or bent and shall be supported by metal straps, blocks or hooks at intervals not to exceed that shown in the following table:

GAS PIPING SUPPORT

SIZE OF PIPE	INTERVALS (feet)
1/2"	6'
3/4" or 1"	8'
1 1/4" or larger (horizontal)	10'
1 1/4" or larger (vertical)	every floor level

Pipe joint compounds used on all gas piping connections shall be resistant to the action of petroleum gases.

An 1/8" NPT plugged tap is required immediately ahead of the unit gas control valve.

All piping connections shall be checked with a soap solution for gas leaks before operating the appliance.

! CAUTION

Some soaps used for leak detection are corrosive to certain metals. Carefully rinse piping thoroughly after leak test has been completed.

The furnace must be isolated by closing the manual shut off valve or disconnected from the gas supply piping during pressure testing of the piping system with pressures in excess of 1/2 PSIG.

The flow of combustion and ventilating air shall not be blocked or otherwise obstructed in any way.

NOTE: All gas-fired heat exchangers are completely tested at the factory before shipment. This will remove nearly all of the oils that have been used in the manufacturing process, however, trace amounts may remain. When performing the initial start-up at the jobsite, it is highly recommended that people or any other living animals, that may be sensitive to the residual odors or gases, NOT be present in the conditioned space during the start-up. In all cases, including the initial factory firing and testing, any of the gases will be under the acceptable level of concentration for human occupancy.

! WARNING

Those sensitive to odors or gases from trace amounts of residual oils should NOT be present in the conditioned space during the start-up of a gas-fired installation.

After electrical power is turned on, set unit controls for heating, and check for operation.

When checking burner operation, flames should be observed as blue with slight or no yellow tipping. There should be no sign of flames floating or lifting off or away from the main burners.

NOTE: In case emergency shut down is required, turn off the main manual gas shut-off valve and disconnect main electrical power to unit. These devices should be properly labeled by the installer.

! WARNING

DO NOT USE OPEN FLAME OR OTHER SOURCE OF IGNITION FOR LEAK TESTING.

When pressure testing the gas supply piping, the furnace must be isolated or disconnected by closing the individual manual shut-off valve from the gas supply. Gas valves can be damaged if subjected to more than 0.5 psig pressure.

INSTALLATION continued

GAS PIPING CAPACITIES

Nominal Iron Pipe Size, Inches	Max. Capacity of Gas Pipe in Cubic Ft. Per Hour*			
	LENGTH OF PIPE, FEET			
	10	50	100	200
3/4"	278	115	79	55
1"	520	215	150	100
1 1/4"	1050	440	305	210
1 1/2"	1600	670	460	320
2	3050	1270	870	610
2 1/2"	4800	2000	1400	980

*At gas pressure of 0.5 PSIG or less and a pressure drop of 0.5 inches of water. Specific gravity = 0.60.

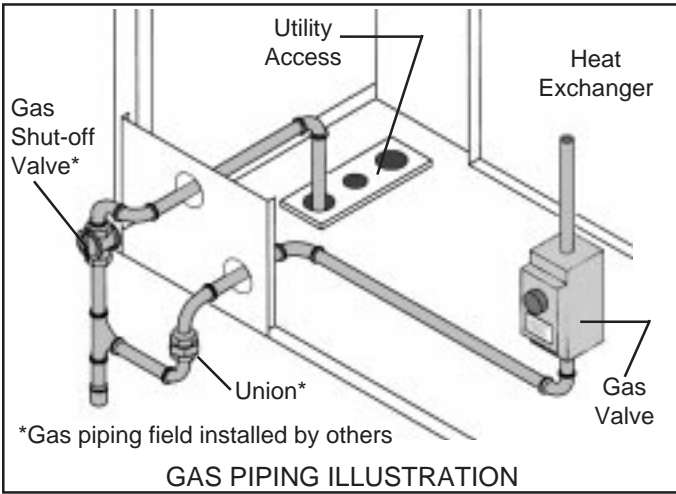

Gas piping information is typical for one gas valve. For units with dual heat exchangers, duplicate gas piping to number two gas valve.



GAS PRESSURE REGULATOR & OVER-PRESSURE PROTECTION DEVICE

On applications where gas service to the unit is greater than 10.5" w.c. and less than 2-psi, a gas pressure regulator must be installed.

At supply pressures in excess of 2-psi and less than 5-psi, ANSI Z21.80 line regulator standard requires a means (an over-pressure protection device / OPD) to limit the downstream pressure to 2-psi maximum, in the event of regulator failure.

In compliance with the ANSI Standard, installations exceeding 2-psi or less than 5-psi nominal require a tested and approved over-pressure protection device for use with the regulator.

For proper heater operation, pressure to the regulator **MUST NOT BE** greater than 5-psi.

CONDENSATE PIPING

The RK equipment is furnished with drain connections and 'P' traps are furnished with the equipment in the same quantity as the drain connections. On the 'A', 'B' and 'C' cabinet models (2 - 25 ton) require one drain connection. On the 'D' cabinet models (26 - 60 ton) all 3 of the drain connections must be used and individually trapped to ensure a minimum amount of condensate will be present in the drain pans.

Drainage of condensate directly onto the roof may be acceptable in certain areas, refer to applicable codes. If condensate is to drain directly onto the roof, a small drip pad should be placed below the drain to protect the roof from possible damage.

When condensate is piped into the building drainage system, the drain pipe should penetrate the roof external to the unit itself. The drain line should be pitched away from the unit at least 1/8 inch per foot. On longer runs, an air break should be used to ensure proper drainage.

Drain pans in any air conditioning equipment, even when they have a built-in slope to the drain, will have moisture present and will require periodic cleaning to prevent any build up of algae or bacteria. Cleaning of the drain pans will also prevent any possible plugging of the drain lines and an overflow of the pan itself. All cleaning of the drain pans and inside of the equipment should be done by qualified personnel.

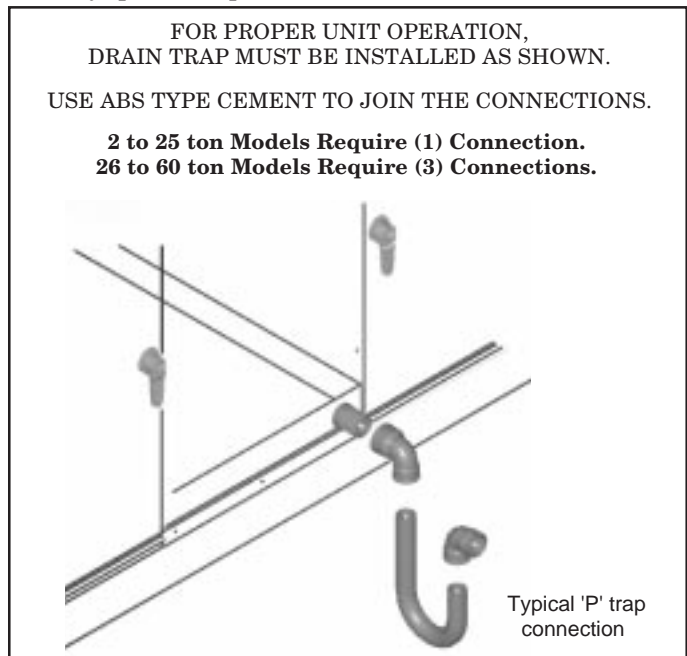



GAS UNIT LIGHTING INSTRUCTIONS

FOR YOUR SAFETY READ BEFORE OPERATING

WARNING: IF YOU DO NOT FOLLOW THESE INSTRUCTIONS EXACTLY, A FIRE OR EXPLOSION MAY RESULT CAUSING PROPERTY DAMAGE, PERSONAL INJURY OR LOSS OF LIFE.

- A. This appliance does not have a pilot. It is equipped with an ignition device which automatically lights the burner. Do **not** try to light the pilot by hand.
- B. BEFORE OPERATING smell all around the appliance area for gas. Be sure to smell next to the floor because some gas is heavier than air and will settle on the floor.
- WHAT TO DO IF YOU SMELL GAS
- Do not try to light any appliance.
 - Do not touch any electric switch; do not use any phone in your building.
 - Immediately call your gas supplier from a neighbor's phone. Follow the gas supplier's instructions.
- If you cannot reach your gas supplier, call the fire department.
- C. Use only your hand to push in or turn the gas control knob. Never use tools. If the knob will not push in or turn by hand, don't try to repair it, call a qualified service technician. Force or attempted repair may result in a fire or explosion.
- D. Do not use this appliance if any part has been under water. Immediately call a qualified service technician to inspect the appliance and to replace any part of the control system and any gas control which has been under water.

OPERATING INSTRUCTIONS

1. STOP! Read the safety information above this label.
2. Set the thermostat to lowest setting.
3. Turn off all electric power to the appliance.
4. This appliance is equipped with an ignition device which automatically lights the burner. Do **not** try to light the pilot by hand.
5. Open control access panel.
6. Push in gas control knob slightly and turn clockwise  to "OFF". NOTE: Knob cannot be turned to "OFF" unless knob is pushed in slightly. Do not force.
7. WAIT five (5) minutes to clear out any gas. Then smell for gas, including near the floor. If you smell gas, STOP! Follow "B" in the safety information above on this label. If you don't smell gas, go to the next step.
8. Turn gas control knob counterclockwise  to "ON".
9. Close control access panel.
10. Turn on all electric power to the appliance.
11. Set thermostat to desired setting.
12. If the appliance will not operate, follow the instructions "To Turn Off Gas To Appliance" and call your service technician or gas supplier.

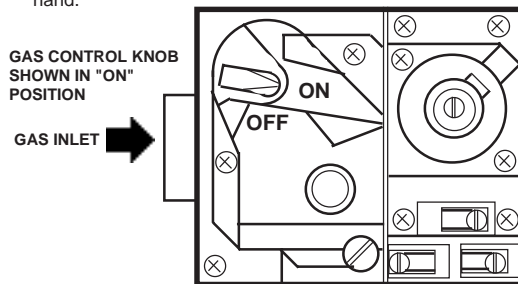

TO TURN OFF GAS TO APPLIANCE

1. Set the thermostat to lowest setting.
2. Turn off all electric power to the appliance if service is to be performed.
3. Open control access panel.
4. Push in gas control knob slightly and turn clockwise  to "OFF". Do not force.
5. Close control access panel.

PERIODIC INSPECTION PROCEDURES

GAS HEATING UNITS

1. The flow of combustion and ventilating air shall not be blocked or otherwise obstructed in any way. The indoor blower, evaporator coil and filters should be inspected monthly.

2. Once each year, before unit is turned on for the heating season, a qualified serviceman should inspect all flue product carrying areas of the furnace and main burners for continued safe operation.

WARNING: At least once each year, a qualified serviceman should check out all of the items listed under the servicing and trouble shooting and maintenance section of this manual.

3. If the induced draft blower/motor assembly has to be replaced, care must be taken to provide an airtight seal between the blower housing and the burner box. High temperature silicone sealant must be used to ensure a good seal.

4. GAS BURNERS

THE BURNERS SHOULD NEVER REQUIRE CLEANING. If cleaning becomes necessary, it indicates faulty operation of the unit. The cleaning should only be done by a qualified service agency and only after consultation with an AAON Service Representative.

It is recommended that if the gas burners require cleaning, call an AAON Service Engineer at (918) 583-2266.

5. HEAT EXCHANGER

The necessity for cleaning the exchanger could indicate faulty operation and should only be checked by a qualified service agency and only after they have discussed the problem with a Service Representative.

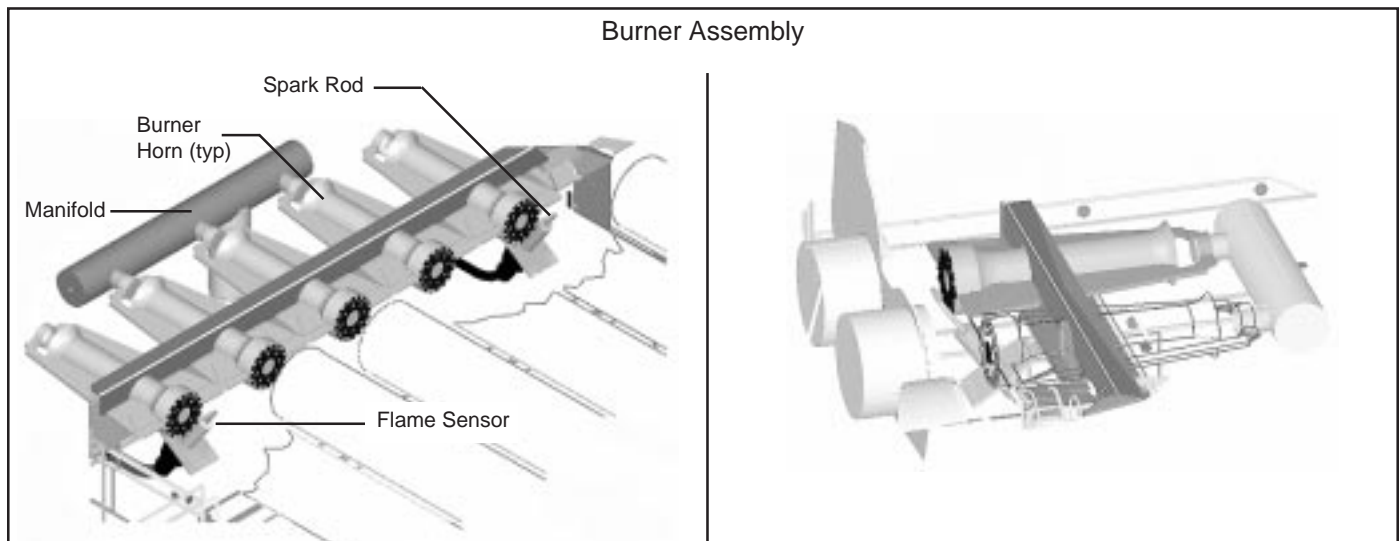
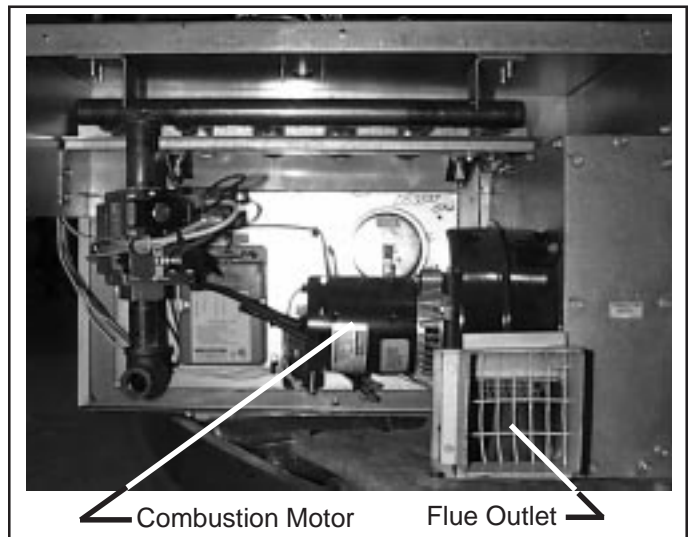
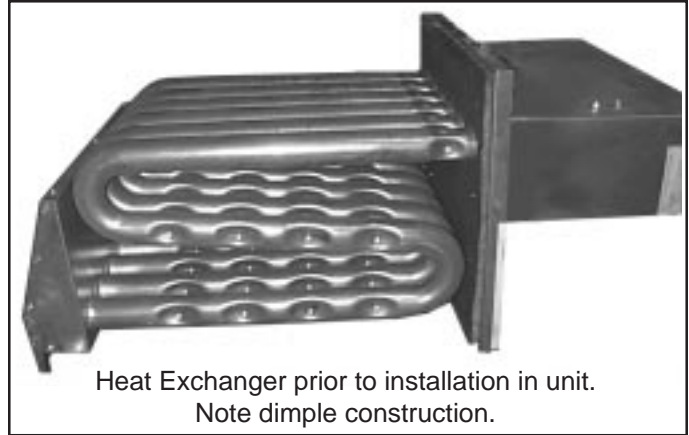

PERIODIC INSPECTION PROCEDURES Continued

COOLING

1. Main Power Switches are on and power is to the unit.
2. Set thermostat in cooling mode and place the "fan" switch to on. Check blower for correct operating direction, amperage and voltage.
3. **PACKAGED UNITS** - Check compressor(s) operation. Check the amperage and compare to the nameplate data (check amperage load side of the compressor contactor).
4. **DX COIL UNITS** - If applicable check remote condenser as per the manufacturer's recommendations.
5. **CHILLED WATER UNITS** - Check remote chiller operations as per the manufacturers instructions. Check coolant flow valves for correct operation and settings.

HEATING • NATURAL GAS

1. Before turning on the main electrical power switch, be sure that all gas supply lines have been purged of air.
2. Turn gas valve to "ON" position.
3. Turn main electrical power switch to "ON" and set the thermostat to call for heat. The vent motor should operate. The control will automatically supply energy to the spark gap and the gas valve after the thermostat contact closes.
4. The sensing probe detects the presence of the flame. (Should no flame be detected in 10 seconds, the ignition system will recycle. If no flame is detected in 3 tries, the ignition system will lockout.)
5. Adjust thermostat to a low temperature setting to open contacts. The main gas flames should be extinguished.

NOTE: The evaporator blower is controlled by the ignition system. In the fan "Auto" mode the blower comes on 45 seconds after flame is proved and goes off 120 seconds after the thermostat opens.

HEATING • ELECTRIC

1. Set thermostat in the heat mode.
2. Set thermostat to call for heat to engage all electric heat strips. Check blower for proper rotation and voltage.
3. Measure the amperage and voltage. Compare them to the nameplate data.

HEATING • STEAM OR HOT WATER

1. Set thermostat in the heat mode.
2. Observe supply blower for proper rotation and voltage.
3. Check boiler or hot water operations according to the manufacturers instructions.
4. Check control flow valves for correct operation and settings per manufacturers instructions.

NOTE:

Should any of the above functions not perform properly, the following sequence of operations are given for the various heating and cooling modes with various control systems for an additional analysis in the case of any problems.

ELECTRIC, STEAM, HOT WATER, COOLING & CHILLED WATER UNITS

1. Indoor blower, coils and filters should be inspected monthly.
2. Once each year, before unit is turned on for the heating season, a qualified serviceman should inspect the unit for proper operation.
3. Inspect all valves and steam traps in accordance with manufacturers recommendations.

WARNING: All of the items listed under the service, trouble shooting and maintenance section of this manual should be performed once a year.



CAUTION

Before leaving installation, a complete operating cycle should be observed to verify that all components are functioning properly.

SERVICING, TROUBLE SHOOTING & MAINTENANCE

LUBRICATION

All original blower motors and bearings are furnished with an original factory charge of lubrication. Some applications will require that bearings be re-lubricated periodically. The schedule will depend on the operating duty, temperature variations or other severe atmospheric conditions.

Bearings should be re-lubricated when at normal operating temperatures, but not running. Rotate the fan shaft by hand and add only enough grease to purge the seals. **DO NOT OVERLUBRICATE.**

Recommended greases are:

SHELL OIL - DOLIUM R
CHEVRON OIL - SRI No. 2
TEXACO INC. - PREMIUM RB

SERVICE

In the event the unit is not functioning correctly and a service company is required, a company with service technicians qualified and experienced in both gas, electric heating and air conditioning be permitted to service the systems in order to keep warranties in effect. The service tech may call the factory if assistance is required.

BEFORE CALLING, HE SHOULD HAVE THE MODEL AND SERIAL NUMBER OF THE UNIT AVAILABLE FOR THE CUSTOMER SERVICE DEPARTMENT TO HELP ANSWER QUESTIONS REGARDING THE UNIT.

AAON, Inc.

Phone: 918-583-2266
Fax: 918-382-6364
Customer Service Department

COMMON CAUSES OF REDUCED AIR FLOW

A. DIRTY FILTERS - Filters must be inspected and replaced on a regular basis. It is strongly recommended that the media be replaced monthly. Clean filters are your best insurance against premature system breakdown.

Do not permit the unit to be operated unless the filters are in place. Operation of the unit without filters will result in a clogged evaporator coil - a very expensive service job to correct.

B. OBSTRUCTION TO AIR FLOW - Supply and return air grilles must be kept clear so air can be freely discharged and drawn from the system.



WARNING

Electric shock hazard. Shut off all electrical power to unit to avoid shock hazard or injury from rotating parts.

CLEANING

Inspect unit interior at the beginning of each heating and cooling season and as operating conditions require.

COILS

Evaporator coil(s) should be inspected and cleaned annually to ensure there is no obstruction to air flow.

Condenser coil(s) should be inspected monthly. Clean condenser coils annually and as required by location or outdoor air conditions.

CONDENSATE DRAIN

Check and clean each year at start of cooling season.

BLOWER

Inspect blower and blower section to keep free of dust or debris. **TURN OFF POWER BEFORE ATTEMPTING TO CLEAN BLOWER WHEEL.**

Typical slide-out blower section



FILTER INSTALLATION / REPLACEMENT

Open filter access door. Slide filters towards you and inspect. Replace old filters with the size indicated on each filter or as shown in the filter chart below. Be sure arrow points towards the blower.
 (Filters should be checked every 30 days and replaced or cleaned as necessary).

IT IS IMPORTANT TO KEEP COILS, BLOWER AND FILTERS CLEAN !

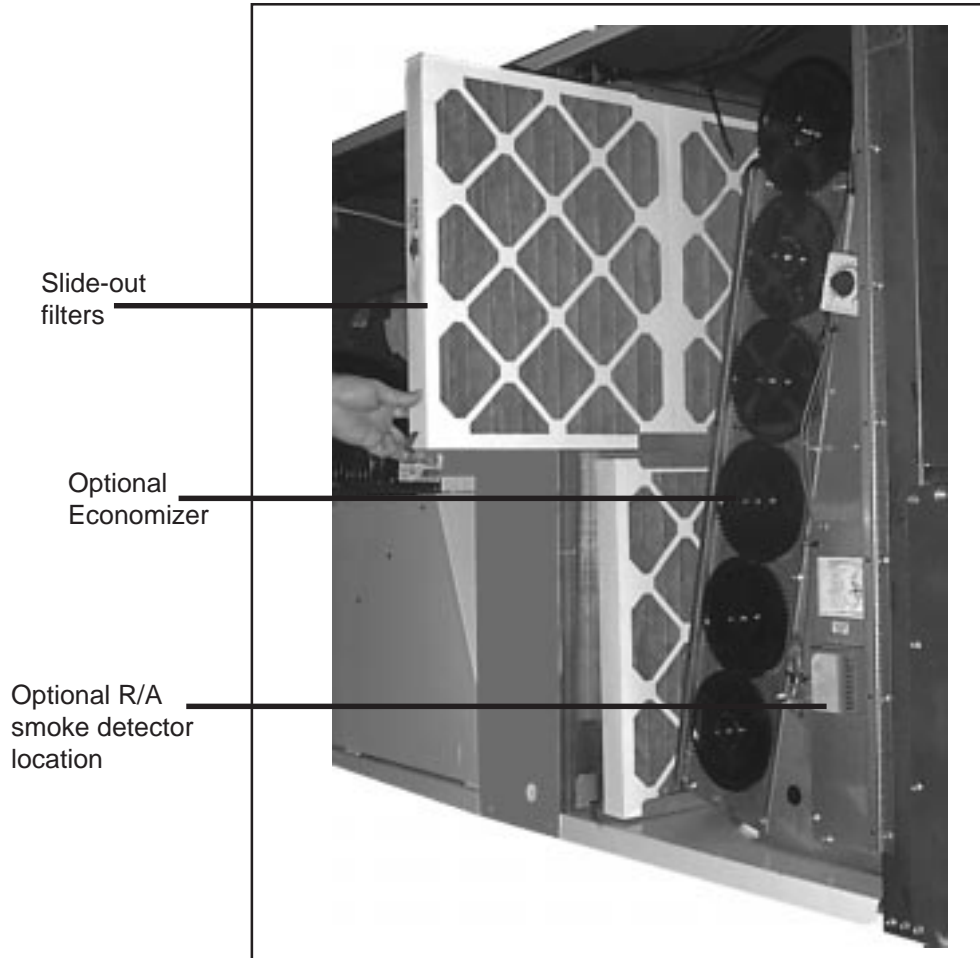

NOTE: CHART REFLECTS STANDARD FACTORY SUPPLIED FILTERS AND SIZES.
 CONTACT FACTORY FOR SPECIAL OPTIONAL FILTER PACKAGES.

FILTERS							
FILTER SIZE (Type)	UNIT SIZE						
	2 - 5	6 & 7	8 & 10	13 & 15	16 - 25	26 - 40	50 & 60
16" x 20" Throwaway (Qty)	4		6				
16" x 20" Pleated (Qty)		4		6			
16" x 25" Pleated (Qty)					2		
20" x 25" Pleated (Qty)					4	10	12
20" x 32" Replaceable Media	2	2					
24" x 40" Replaceable Media			2				
17" x 47" Replaceable Media				3			

FILTERS SHOULD BE REPLACED EVERY 30 DAYS OR AS REQUIRED.

SERVICING

TROUBLE	POSSIBLE CAUSE
ELECTRIC HEATING	
SYSTEM OFF	<ol style="list-style-type: none"> 1. Check power at line side of contactor(s). 2. Thermostat not set for heating.
EVAPORATOR MOTOR WILL NOT RUN	<ol style="list-style-type: none"> 1. Overload relay tripped. 2. Heater Relay not energized. 3. Blower Contactor not energized. 4. Capacitor shorted or open (PSC motors only).
BLOWER DOESN'T DELIVER AIR	<ol style="list-style-type: none"> 1. Blower running backwards. 2. Dirty air filters. 3. Dirty coils. 4. Duct obstruction. 5. Belts loose.
BLOWER COMES ON, BUT LITTLE OR NO HEAT	<ol style="list-style-type: none"> 1. One or more heater contactors are open. 2. Limit switches are open. 3. Heater relay open. 4. Heat strips burned out.
GAS HEATING	
SYSTEM OFF	<ol style="list-style-type: none"> 1. Check power and gas supply. 2. Check thermostat switches and settings. 3. Check 24 volt power to ignition control.
BURNER WON'T COME ON	<ol style="list-style-type: none"> 1. Check for power at main gas valve. 2. Defective gas valve. 3. Loose or broken connection to gas valve. 4. Check limit controls for open. 5. Check continuity of differential pressure switch with motor turning. If open, replace differential pressure switch. 6. Defective ignition control.
COMBUSTION AIR BLOWER WON'T RUN	<ol style="list-style-type: none"> 1. Thermostat not calling for heat. 2. Relay not closing. (No power to motor) 3. Motor stuck or winding open. 4. Internal motor overload open.
BURNER GOES "OFF" ON HIGH LIMIT	<ol style="list-style-type: none"> 1. Unit blower not coming on. (Check fan control) 2. Blower motor running backward. 3. Filters dirty. 4. Ducts obstructed or dampers closed. 5. Manifold gas pressure too high.
IGNITION ON, BURNER WON'T LIGHT	<ol style="list-style-type: none"> 1. Hand valve "off" (turn to on)(main gas valve). 2. Gas off or very low pressure. 3. Check for power at main gas valve. 4. Check continuity of differential pressure switch with motor turning. If open, replace differential pressure switch. 5. Sparker sensor out of adjustment. 6. Main orifice blocked.
SUPPLY FAN BLOWER WON'T RUN	<ol style="list-style-type: none"> 1. Defective Ignition Control. 2. See cooling trouble shooting page 19.

SERVICING Continued

TROUBLE	POSSIBLE CAUSE
STEAM AND HOT WATER HEATING	
SYSTEM OFF	<ol style="list-style-type: none"> 1. Check power at line side of contactor(s). 2. Thermostat not set for heating.
BLOWER MOTOR WILL NOT RUN	<ol style="list-style-type: none"> 1. Overload relay tripped. 2. Heater Relay not energized. 3. Blower Contactor not energized.
BLOWER DOESN'T DELIVER AIR	<ol style="list-style-type: none"> 1. Blower running backwards. 2. Dirty air filters. 3. Dirty coils. 4. Duct obstruction. 5. Belts loose.
BLOWER COMES ON, BUT LITTLE OR NO HEAT	<ol style="list-style-type: none"> 1. Check steam traps, valves, and steam or hot water supply in accordance with manufactures instructions. 2. Faulty thermostat.
COOLING PACKAGE and UNITS with REMOTE CONDENSERS	
SYSTEM OFF	<ol style="list-style-type: none"> 1. Check power at lineside of contactor(s). 2. Thermostat not set for cooling. 3. High pressure control tripped. 4. Low pressure switch open (loss of charge).
CONDENSER FAN WILL NOT RUN	<ol style="list-style-type: none"> 1. Overload thermal protector open in motor. 2. Motor run capacitor open or shorted. 3. Motor failed. 4. Fan or shaft stuck.
EVAPORATOR BLOWER WILL NOT RUN	<ol style="list-style-type: none"> 1. Overload thermal protector open in motor. 2. Relay not closing. 3. Motor failed. 4. Capacitor shorted or open (PSC motors only). 5. Stuck shaft or blower wheel.
COMPRESSOR SHORT CYCLES	<ol style="list-style-type: none"> 1. Check for low refrigeration charge. 2. Compressor overload setting. 3. Ambient temperature too low. 4. Filters dirty or air flow restricted. 5. Evaporator blower not running.
FAN MOTOR RUNS HOT AND CUTS OUT	<ol style="list-style-type: none"> 1. Line voltage too high.
COMPRESSOR WILL NOT START	<ol style="list-style-type: none"> 1. Line voltage too low. 2. Limit switches are open. 3. Overload or pressure control tripped.
BLOWER DOES NOT DELIVER AIR	<ol style="list-style-type: none"> 1. Blower running backwards. 2. Dirty filters. 3. Duct obstruction. 4. Belts loose.

SERVICING Continued

TROUBLE	POSSIBLE CAUSE
COOLING - CHILLED WATER	
SYSTEM OFF	<ol style="list-style-type: none">1. Check power at line side of contactor(s).2. Thermostat not set for cooling.
EVAPORATOR BLOWER WILL NOT RUN	<ol style="list-style-type: none">1. Overload thermal protector open in motor.2. Contactor not closing.3. Motor failed.
FAN MOTOR RUNS HOT AND CUTS OUT	<ol style="list-style-type: none">1. Line voltage too high.
BLOWER DOES NOT DELIVER AIR	<ol style="list-style-type: none">1. Blower running backwards.2. Dirty air filters.3. Duct obstruction.4. Belt loose.
BLOWER COMES ON, BUT LITTLE OR NO COOLING	<ol style="list-style-type: none">1. Check supply water and temperature.2. Check water control valves operation.3. Check water temperature rise entering and leaving unit to determine if adequate water is flowing.

ROOFTOP UNIT REPLACEMENT PARTS

Replacement parts for AAON equipment may be obtained from AAON. When ordering parts, always reference the unit model number, serial number and part number.

AAON, Inc.

Customer Service Department

2425 South Yukon Ave • Tulsa, Oklahoma 74107

Phone: 918-583-2266 • Fax: 918-382-6364

ALWAYS USE AAON SPECIFIED PARTS

SEQUENCE OF OPERATIONS

I. GENERAL INFORMATION

A. HEATING

1. Natural Gas

When the thermostat calls for heating, W1 makes R to the heat relay (HR) all N.O. (Normally open) contacts close and all N.C. (normally closed) contacts open. The combustion motor starts and as the pressure decreases in the flue outlet box the ignition control is energized. The control sends 24 VAC to the main gas valve and high voltage to the ignitor. If a burner flame has been detected after 10 seconds, the spark is extinguished and the flame continues. If a flame has not been detected after 10 seconds, the gas valve closes, the spark ceases and the induced draft blower continues to purge the heat exchanger. After 45 seconds of purge, the ignition system will attempt to light the burners again. Should no flame be detected after 3 tries, the ignition control locks out the system.

On a fault the gas train is shut down by a main limit located in the heat exchanger area or by an auxiliary limit mounted in the supply air fan housing.

2. LP (Propane) Gas

The sequence for LP Gas is the same as above but upon non-proof of burner the gas train will enter a 100% lockout condition.

3. Electric

When the thermostat calls for heat 'W1' makes 'R' to the heat relay 'HR'. All N.O. contacts close, and all N.C. contacts open. The heat relay makes 'R' to the first stage of electric heat.

On a fault condition the main limit located in the supply air or the auxiliary limit located in the supply air fan housing will remove power from all contactors.

If additional heating is required a second set of elements can be turned on by 'W2'.

OPTIONAL - When available the electric heat can be sequenced to provide a constant discharge air temperature.

4. Steam or Hot Water

This option adds a steam coil down stream of the cooling coil (if supplied). Connections and controls are provided by others.

B. COOLING

1. Packaged Units

When the thermostat calls for cooling from the space, 'Y1' makes 'R' to 'CC1' through the LPS (low pressure switch), HPS (high pressure switch) and optional GOT (guarantee off timer).

On units 26 through 60 tons 'CC3' is also made. If additional cooling is required 'CC2' and 'CC4' (on 26-60 ton) are made through their respective pressure switches and timers.

2. DX Only - Coil Units

When the thermostat calls for cooling from the space, the condensing unit is energized (refer to manufacturers instructions for sequence of operation). The evaporator blower contactor is energized simultaneously with the condensing section.

3. Chilled Water Coil Units

The blower contactor is energized to provide supply air on a signal from the space thermostat. All other controls are by others.

C. OPTIONAL ECONOMIZER

When cooling is called for and the unit has the economizer option installed, temperature switch ECS (or Enthalpy) allows the economizer operation when the outside air reaches the required setpoint. (Some options use dry bulb sensing and some options use enthalpy sensing to determine the outside air (O.A.) condition).

When the economizer is in operation 'Y1' controls the opening and closing of the dampers, 'Y2' is then able to control the compressors which 'Y1' normally controls. A modulating economizer is also available. The operation is the same as the standard economizer except that the motor modulates the damper position to maintain a preset mixed air temperature.

SEQUENCE OF OPERATIONS Continued

II. VAV (Variable Air Volume) SYSTEMS

When a call for cooling is received, the controller board stages on compressors to maintain a field set supply air temperature. As different zones become satisfied their VAV boxes will close. (Boxes and controls are supplied and installed by others). This in turn causes the supply duct pressure to rise. The VAV controller board senses this increase in pressure and modulates the supply fan speed to maintain the required field set supply air pressure setpoint.

Normally VAV units are cooling only units. There are certain applications where electric or gas heat is used to provide morning warmup. When gas or electric heat is used for morning warmup the airflow will not be allowed to vary. The fan speed control will be disabled until a call for cooling is received, then the heating system will be locked out and VAV will be enabled.

III. POWER EXHAUST OPTIONS

When space over pressurization occurs, due to economizer operation, a power exhaust will be utilized to provide relief. Two types of power exhaust control are available.

A. Three position economizer, an On/Off power exhaust will be utilized to exhaust when economizer is called for.

The end switch located on the economizer O. A. Damper section is field adjustable to allow for differences in building design. The switch engages and disengages the power exhaust motor(s) through a contactor. The end switch is in the 24 VAC circuit.

B. Full modulating economizer, a full modulating power exhaust will control the amount of actual exhausted air by means of a building sensing pressure control which opens or closes according to desired pressure in the space.

POWER EXHAUST w/ 3 POSITION ECON.

In the unit "OFF" or in the minimum economizer position, the power exhaust fan is off. When the unit goes to 100% outside air operation, the power exhaust fan motor starts and operates until the unit is shut off or the economizer goes back to minimum position.

POWER EXHAUST w/ FULL MODULATING ECON.

In the unit "OFF" or in the minimum economizer position, the power exhaust is off. As the economizer begins to modulate open, an end switch (adjustable) closes which starts the power exhaust fan motor. The power exhaust operates until the economizer modulates below the end switch setting or the unit is shut off.

POWER EXHAUST w/ FULL MODULATING ECON. WITH BUILDING PRESSURE CONTROL

In the unit "OFF" or in the minimum economizer position the power exhaust is off. As the economizer begins to modulate open, an end switch (adjustable) closes which starts the power exhaust fan motor. The amount of exhaust air is controlled by a set of dampers in response to the unit mounted building static pressure controller. The power exhaust operates until the economizer modulates below the end switch setting or the unit is shut off. (NOTE: Static pressure sensing tubing is field supplied and installed).

COMPRESSOR CHECKOUT PROCEDURE

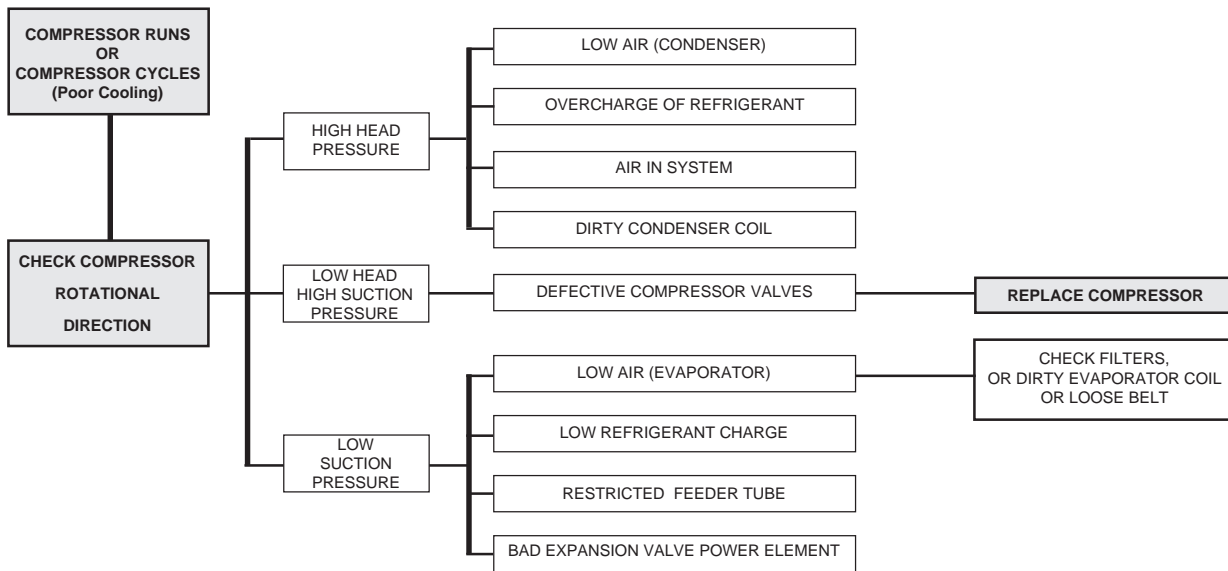
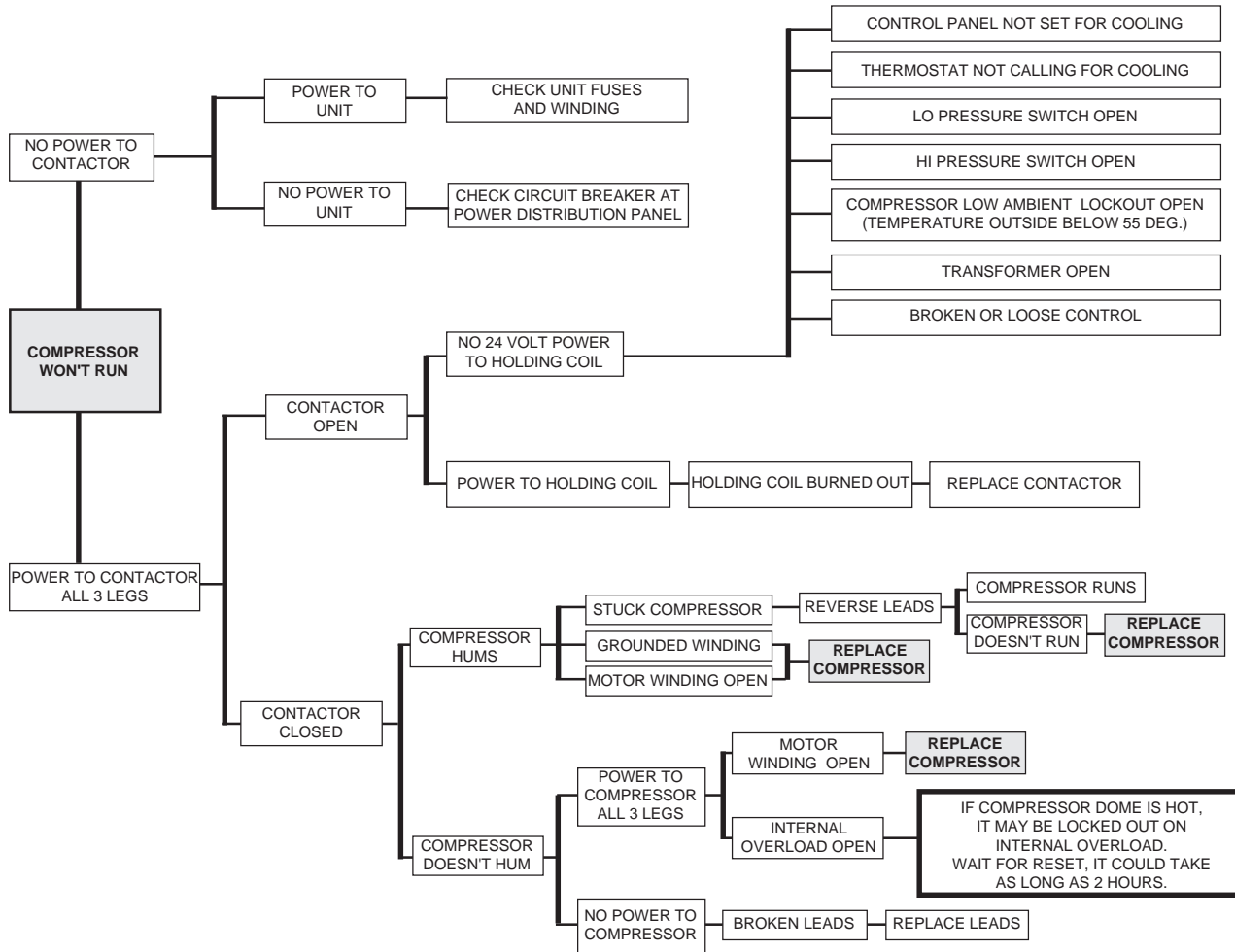

IGNITION CONTROL CHECKOUT PROCEDURE

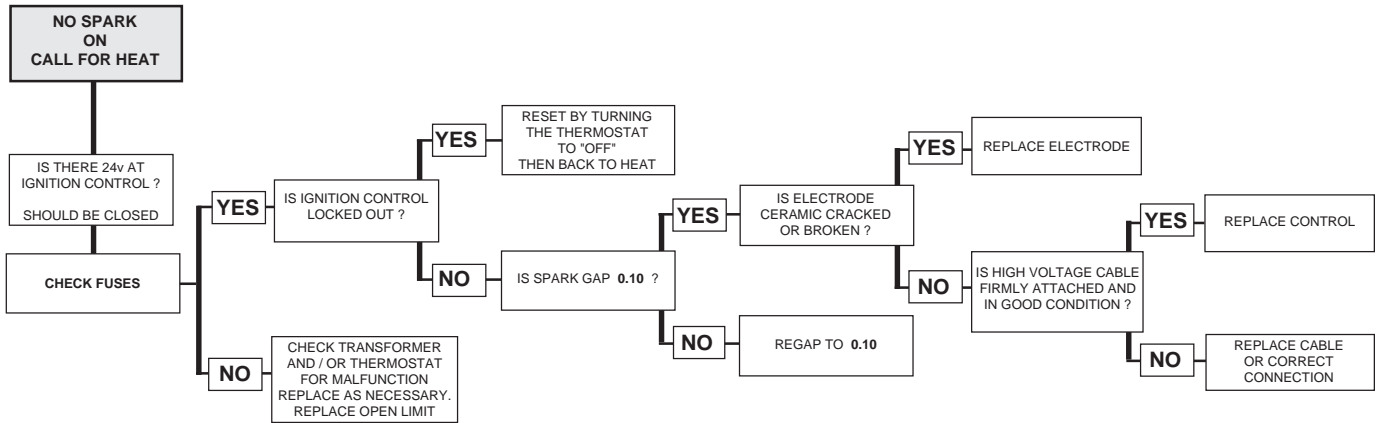
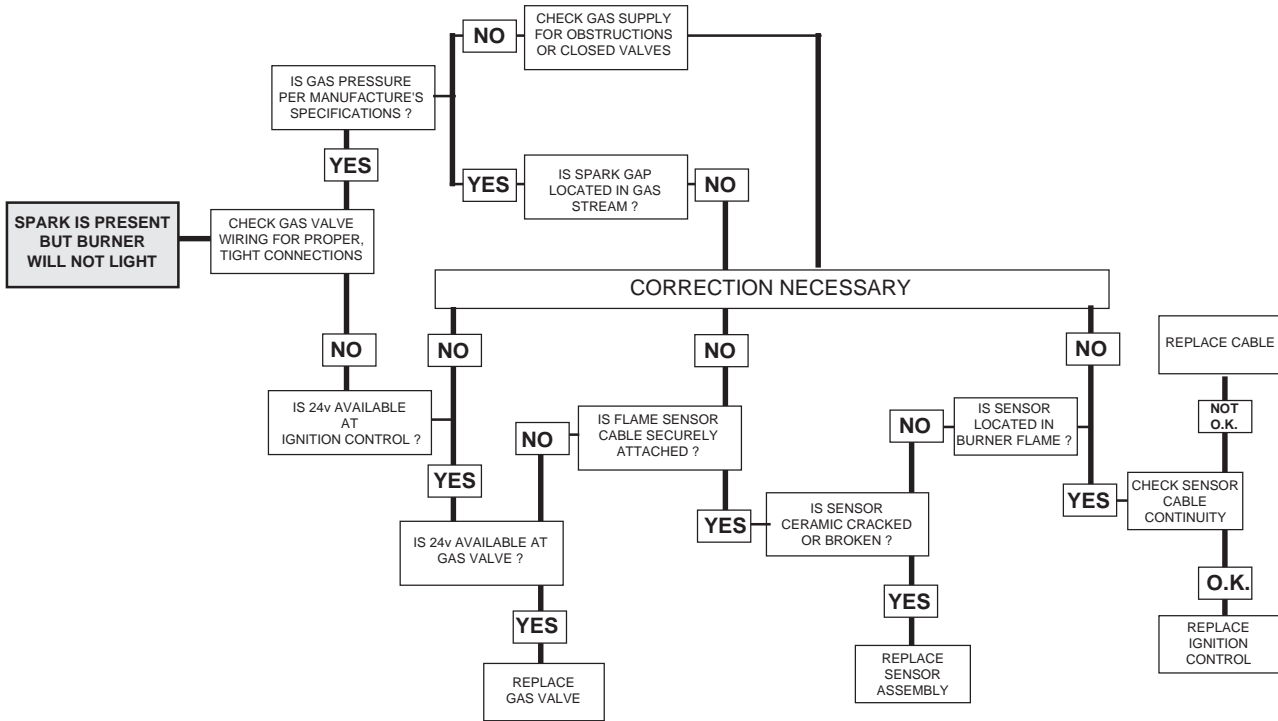

JOB NAME: _____ DATE: _____
 ADDRESS: _____ MODEL No: _____
 CITY, STATE: _____ SERIAL No: _____
 START-UP CONTRACTOR: _____ RTU No: _____

START-UP CHECK LIST • GENERAL CHECKS

Inspect Unit For Damage:	<input type="checkbox"/>	Verify All Air Filters Are Installed:	<input type="checkbox"/>
Check All Fans For Free Movement:	<input type="checkbox"/>	Inspect Economizer Damper Assembly:	<input type="checkbox"/>
Verify All Copper Tubing Is Isolated So It Doesn't Rub:	<input type="checkbox"/>	Verify Voltage:	<input type="checkbox"/>
Check & Tighten All Electrical Terminals:	<input type="checkbox"/>	Verify Transformer Tap On 208/230v Equip.:	<input type="checkbox"/>
Tighten All Set Screws On Pulleys, Bearings & Fans:	<input type="checkbox"/>	Open Outside Air Hood (if applicable):	<input type="checkbox"/>

Additional Checks and Notes: _____

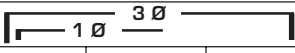
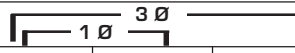
EVAPORATOR BLOWER ASSEMBLY				POWER EXHAUST ASSEMBLY			
FAN(S) ALIGNMENT:	<input type="checkbox"/>	BELT(S) TENSION:	<input type="checkbox"/>	FAN(S) ALIGNMENT:	<input type="checkbox"/>	BELT(S) TENSION:	<input type="checkbox"/>
CHECK FAN ROTATION:	<input type="checkbox"/>	VAV CONTROLS:	<input type="checkbox"/>	CHECK FAN ROTATION:	<input type="checkbox"/>	AUTO AIR BALANCE:	<input type="checkbox"/>
NAMEPLATE AMPS: _____				NAMEPLATE AMPS: _____			
MOTOR MAKE / AMPS				MOTOR MAKE / AMPS			
1				1			
2				2			

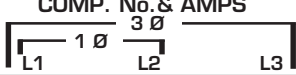
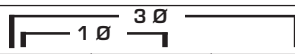
COOLING TEST • AMB. TEMP: _____ °F					CONDENSER ASSEMBLY				
COMP. No. & AMPS			Crankcase Heater Amps	Head Pressure PSIG	Suction Pressure PSIG	NAMEPLATE AMPS: _____			
									
1						1			
2						2			
3						3			
4						4			
5						5			
6						6			
7						7			
8						8			

HEATING TEST • NATURAL GAS • LP GAS				HEATING TEST • ELECTRIC •			
<input type="checkbox"/> NATURAL GAS <input type="checkbox"/> PROPANE (L.P.)				HEATER No. & AMPS			
VERIFY INLET GAS PRESSURE:	<input type="checkbox"/>	W.C.		1			11
(refer to data plate)				2			12
PURGE AIR FROM LINES:	<input type="checkbox"/>			3			13
VERIFY PILOT SPARK:	<input type="checkbox"/>			4			14
MANIFOLD PRESSURE				5			15
SINGLE STAGE:	<input type="checkbox"/>	W.C.		6			16
1st STAGE LOW FIRE:	<input type="checkbox"/>	W.C.		7			17
2nd STAGE HIGH FIRE:	<input type="checkbox"/>	W.C.		8			18
				9			19
				10			20

ECONOMIZER	MISC. CONTROLS
TYPE: _____ MOTOR TYPE: _____	_____
WIRING: _____ GEARS: _____	_____
OPERATION: _____	_____
ECON. CHG.OVER • TYPE: _____ OPERATION: <input type="checkbox"/>	_____

START-UP TECHNICIAN: _____ START-UP VERIFIED BY: _____

AAON[®]
ROOFTOP
UNITS



RK SERIES

INSTALLATION
INSTRUCTION
MANUAL

AAON, Inc.

2425 South Yukon

Tulsa, Oklahoma 74107

ph: (918) 583-2266 • fax: (918) 583-6094